

THREE TERMINAL POSITIVE VOLTAGE REGULATORS
5V, 6V, 8V, 9V, 10V, 12V, 15V, 18V, 20V, 24V.

FEATURES

- Suitable for TTL, DTL, HTL, C-MOS Power Supply.
- Internal Short-Circuit Current Limiting.
- Internal Thermal Overload Protection.
- Maximum Output Current of 150mA ($T_j=25^\circ\text{C}$).
- Packaged in TO-92.

MAXIMUM RATINGS ($T_a=25^\circ\text{C}$)

CHARACTERISTIC	SYMBOL	RATING	UNIT
Input Voltage	V_{IN}	35	V
		40	V
Power Dissipation	P_D	600	mW
Operating Junction Temperature	T_j	-30 ~ 150	$^\circ\text{C}$
Operating Temperature	T_{opr}	-30 ~ 75	$^\circ\text{C}$
Storage Temperature	T_{stg}	-55 ~ 150	$^\circ\text{C}$

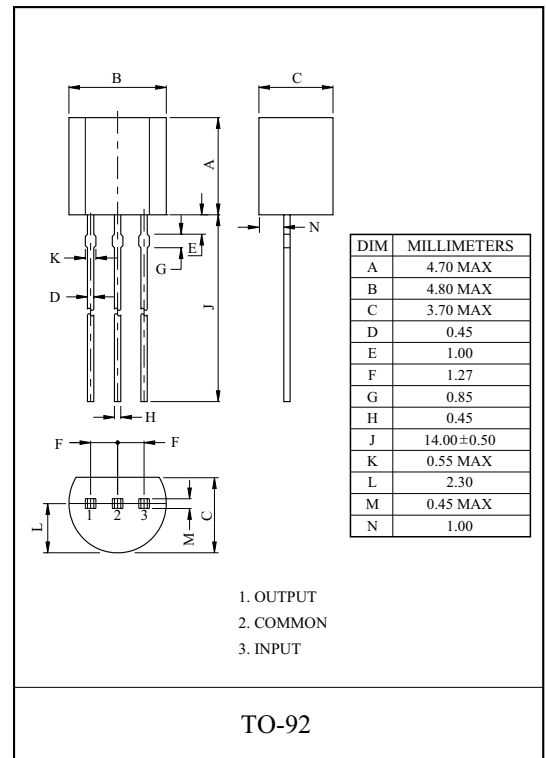

EQUIVALENT CIRCUIT

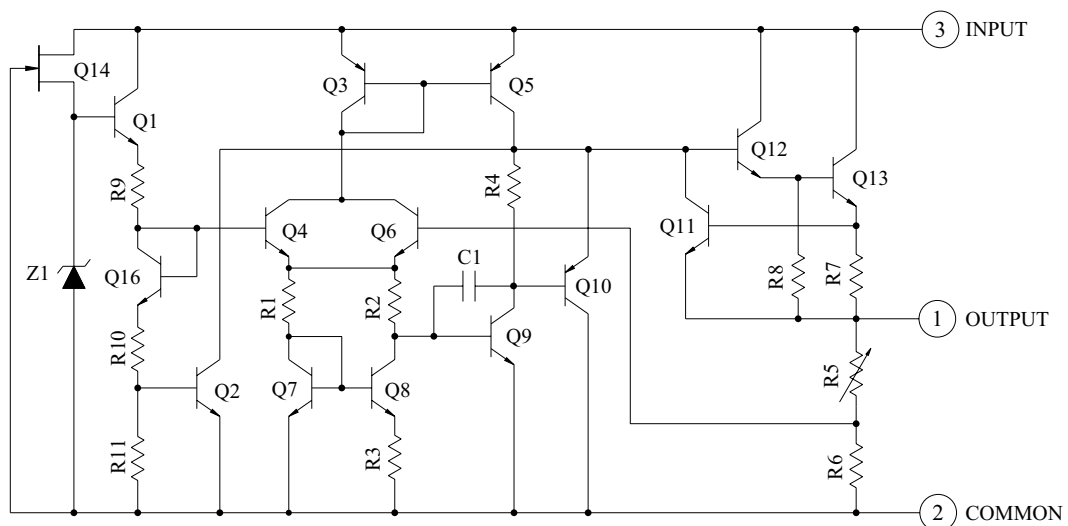

KIA78S05P~KIA78S24P

ELECTRICAL CHARACTERISTICS

KIA78S05P

(Unless otherwise specified, $V_{IN}=10V$, $I_{OUT}=40mA$, $C_{IN}=0.33\mu F$, $C_{OUT}=0.1\mu F$, $0^{\circ}C \leq T_j \leq 125^{\circ}C$)

CHARACTERISTIC	SYMBOL	TEST CIRCUIT	TEST CONDITION	MIN.	TYP.	MAX.	UNIT	
Output Voltage	V_{OUT}	1	$T_j=25^{\circ}C$	4.8	5.0	5.2	V	
Input Regulation	Reg line	1	$T_j=25^{\circ}C$	$7.0V \leq V_{IN} \leq 20V$	-	55	150	mV
				$8.0V \leq V_{IN} \leq 20V$	-	45	100	
Load Regulation	Reg load	1	$T_j=25^{\circ}C$	$1.0mA \leq I_{OUT} \leq 100mA$	-	11	60	mV
				$1.0mA \leq I_{OUT} \leq 40mA$	-	5.0	30	
Output Voltage	V_{OUT}	1	$7.0V \leq V_{IN} \leq 20V$ $1.0mA \leq I_{OUT} \leq 40mA$	4.75	-	5.25	V	
			$V_{IN}=10V$, $1.0mA \leq I_{OUT} \leq 70mA$	4.75	-	5.25		
Quiescent Current	I_B	1	$T_j=25^{\circ}C$	-	3.1	6.0	mA	
			$T_j=125^{\circ}C$	-	-	5.5		
Quiescent Current Change	ΔI_B	1	$8.0V \leq V_{IN} \leq 20V$	-	-	1.5	mA	
			$1.0mA \leq I_{OUT} \leq 40mA$	-	-	0.1		
Output Noise Voltage	V_{NO}	1	$T_a=25^{\circ}C$, $10Hz \leq f \leq 100kHz$	-	40	-	μV_{rms}	
Long Term Stability	$\Delta V_{OUT} / \Delta t$	1		-	12	-	mV/ 1.0kHrs	
Ripple Rejection Ratio	RR	2	$f=120Hz$, $8.0V \leq V_{IN} \leq 18V$, $T_j=25^{\circ}C$	41	49	-	dB	
Dropout Voltage	$ V_{IN}-V_{OUT} $	1	$T_j=25^{\circ}C$	-	1.7	-	V	
Average Temperature Coefficient of Output Voltage	TC_{VO}	1	$I_{OUT}=5mA$	-	-0.6	-	mV/ $^{\circ}C$	

KIA78S05P~KIA78S24P

ELECTRICAL CHARACTERISTICS

KIA78S06P

(Unless otherwise specified, $V_{IN}=11V$, $I_{OUT}=40mA$, $C_{IN}=0.33\mu F$, $C_{OUT}=0.1\mu F$, $0^{\circ}C \leq T_j \leq 125^{\circ}C$)

CHARACTERISTIC	SYMBOL	TEST CIRCUIT	TEST CONDITION	MIN.	TYP.	MAX.	UNIT	
Output Voltage	V_{OUT}	1	$T_j=25^{\circ}C$	5.76	6.0	6.24	V	
Input Regulation	Reg line	1	$T_j=25^{\circ}C$	$8.1V \leq V_{IN} \leq 21V$	-	50	150	mV
				$9.0V \leq V_{IN} \leq 21V$	-	45	110	
Load Regulation	Reg load	1	$T_j=25^{\circ}C$	$1.0mA \leq I_{OUT} \leq 100mA$	-	12	70	mV
				$1.0mA \leq I_{OUT} \leq 40mA$	-	5.5	35	
Output Voltage	V_{OUT}	1	$8.1V \leq V_{IN} \leq 21V$ $1.0mA \leq I_{OUT} \leq 40mA$	5.7	-	6.3	V	
			$V_{IN}=11V$, $1.0mA \leq I_{OUT} \leq 70mA$	5.7	-	6.3		
Quiescent Current	I_B	1	$T_j=25^{\circ}C$	-	3.1	6.0	mA	
			$T_j=125^{\circ}C$	-	-	5.5		
Quiescent Current Change	ΔI_B	1	$9.0V \leq V_{IN} \leq 20V$	-	-	1.5	mA	
			$1.0mA \leq I_{OUT} \leq 40mA$	-	-	0.1		
Output Noise Voltage	V_{NO}	1	$T_a=25^{\circ}C$, $10Hz \leq f \leq 100kHz$	-	40	-	μV_{rms}	
Long Term Stability	$\Delta V_{OUT} / \Delta t$	1		-	14	-	mV/ 1.0kHrs	
Ripple Rejection Ratio	RR	2	$f=120Hz$, $9.0V \leq V_{IN} \leq 19V$, $T_j=25^{\circ}C$	39	47	-	dB	
Dropout Voltage	$ V_{IN}-V_{OUT} $	1	$T_j=25^{\circ}C$	-	1.7	-	V	
Average Temperature Coefficient of Output Voltage	TC_{VO}	1	$I_{OUT}=5mA$	-	-0.7	-	mV/ $^{\circ}C$	

KIA78S05P~KIA78S24P

ELECTRICAL CHARACTERISTICS

KIA78S08P

(Unless otherwise specified, $V_{IN}=14V$, $I_{OUT}=40mA$, $C_{IN}=0.33\mu F$, $C_{OUT}=0.1\mu F$, $0^{\circ}C \leq T_j \leq 125^{\circ}C$)

CHARACTERISTIC	SYMBOL	TEST CIRCUIT	TEST CONDITION	MIN.	TYP.	MAX.	UNIT	
Output Voltage	V_{OUT}	1	$T_j=25^{\circ}C$	7.7	8.0	8.3	V	
Input Regulation	Reg line	1	$T_j=25^{\circ}C$	$10.5V \leq V_{IN} \leq 23V$	-	20	175	mV
				$11V \leq V_{IN} \leq 23V$	-	12	125	
Load Regulation	Reg load	1	$T_j=25^{\circ}C$	$1.0mA \leq I_{OUT} \leq 100mA$	-	15	80	mV
				$1.0mA \leq I_{OUT} \leq 40mA$	-	7.0	40	
Output Voltage	V_{OUT}	1	$10.5V \leq V_{IN} \leq 23V$ $1.0mA \leq I_{OUT} \leq 40mA$	7.6	-	8.4	V	
			$V_{IN}=14V$, $1.0mA \leq I_{OUT} \leq 70mA$	7.6	-	8.4		
Quiescent Current	I_B	1	$T_j=25^{\circ}C$	-	3.1	6.5	mA	
			$T_j=125^{\circ}C$	-	-	6.0		
Quiescent Current Change	ΔI_B	1	$11V \leq V_{IN} \leq 23V$	-	-	1.5	mA	
			$1.0mA \leq I_{OUT} \leq 40mA$	-	-	0.1		
Output Noise Voltage	V_{NO}	1	$T_a=25^{\circ}C$, $10Hz \leq f \leq 100kHz$	-	60	-	μV_{rms}	
Long Term Stability	$\Delta V_{OUT} / \Delta t$	1		-	20	-	mV/ 1.0kHrs	
Ripple Rejection Ratio	RR	2	$f=120Hz$, $12V \leq V_{IN} \leq 23V$, $T_j=25^{\circ}C$	37	45	-	dB	
Dropout Voltage	$ V_{IN}-V_{OUT} $	1	$T_j=25^{\circ}C$	-	1.7	-	V	
Average Temperature Coefficient of Output Voltage	TC_{VO}	1	$I_{OUT}=5mA$	-	-0.8	-	mV/ $^{\circ}C$	

KIA78S05P~KIA78S24P

ELECTRICAL CHARACTERISTICS

KIA78S09P

(Unless otherwise specified, $V_{IN}=15V$, $I_{OUT}=40mA$, $C_{IN}=0.33\mu F$, $C_{OUT}=0.1\mu F$, $0^{\circ}C \leq T_j \leq 125^{\circ}C$)

CHARACTERISTIC	SYMBOL	TEST CIRCUIT	TEST CONDITION	MIN.	TYP.	MAX.	UNIT	
Output Voltage	V_{OUT}	1	$T_j=25^{\circ}C$	8.64	9.0	9.36	V	
Input Regulation	Reg line	1	$T_j=25^{\circ}C$	$11.4V \leq V_{IN} \leq 24V$	-	80	200	mV
				$12V \leq V_{IN} \leq 24V$	-	20	160	
Load Regulation	Reg load	1	$T_j=25^{\circ}C$	$1.0mA \leq I_{OUT} \leq 100mA$	-	17	90	mV
				$1.0mA \leq I_{OUT} \leq 40mA$	-	8.0	45	
Output Voltage	V_{OUT}	1	$11.4V \leq V_{IN} \leq 24V$ $1.0mA \leq I_{OUT} \leq 40mA$	8.55	-	9.45	V	
			$V_{IN}=15V$, $1.0mA \leq I_{OUT} \leq 70mA$	8.55	-	9.45		
Quiescent Current	I_B	1	$T_j=25^{\circ}C$	-	3.2	6.5	mA	
			$T_j=125^{\circ}C$	-	-	6.0		
Quiescent Current Change	ΔI_B	1	$11.5V \leq V_{IN} \leq 26V$	-	-	1.5	mA	
			$1.0mA \leq I_{OUT} \leq 40mA$	-	-	0.1		
Output Noise Voltage	V_{NO}	1	$T_a=25^{\circ}C$, $10Hz \leq f \leq 100kHz$	-	65	-	μV_{rms}	
Long Term Stability	$\Delta V_{OUT}/\Delta t$	1		-	21	-	mV/ 1.0kHrs	
Ripple Rejection Ratio	RR	2	$f=120Hz$, $12V \leq V_{IN} \leq 24V$, $T_j=25^{\circ}C$	36	44	-	dB	
Dropout Voltage	$ V_{IN}-V_{OUT} $	1	$T_j=25^{\circ}C$	-	1.7	-	V	
Average Temperature Coefficient of Output Voltage	TC_{VO}	1	$I_{OUT}=5mA$	-	-0.85	-	mV/ $^{\circ}C$	

KIA78S05P~KIA78S24P

ELECTRICAL CHARACTERISTICS

KIA78S10P

(Unless otherwise specified, $V_{IN}=16V$, $I_{OUT}=40mA$, $C_{IN}=0.33\mu F$, $C_{OUT}=0.1\mu F$, $0^{\circ}C \leq T_j \leq 125^{\circ}C$)

CHARACTERISTIC	SYMBOL	TEST CIRCUIT	TEST CONDITION	MIN.	TYP.	MAX.	UNIT	
Output Voltage	V_{OUT}	1	$T_j=25^{\circ}C$	9.6	10	10.4	V	
Input Regulation	Reg line	1	$T_j=25^{\circ}C$	$12.5V \leq V_{IN} \leq 25V$	-	80	230	mV
				$13V \leq V_{IN} \leq 25V$	-	30	170	
Load Regulation	Reg load	1	$T_j=25^{\circ}C$	$1.0mA \leq I_{OUT} \leq 100mA$	-	18	90	mV
				$1.0mA \leq I_{OUT} \leq 40mA$	-	8.5	45	
Output Voltage	V_{OUT}	1	$12.5V \leq V_{IN} \leq 25V$ $1.0mA \leq I_{OUT} \leq 40mA$	9.5	-	10.5	V	
			$V_{IN}=16V$, $1.0mA \leq I_{OUT} \leq 70mA$	9.5	-	10.5		
Quiescent Current	I_B	1	$T_j=25^{\circ}C$	-	3.2	6.5	mA	
			$T_j=125^{\circ}C$	-	-	6.0		
Quiescent Current Change	ΔI_B	1	$13V \leq V_{IN} \leq 25V$	-	-	1.5	mA	
			$1.0mA \leq I_{OUT} \leq 40mA$	-	-	0.1		
Output Noise Voltage	V_{NO}	1	$T_a=25^{\circ}C$, $10Hz \leq f \leq 100kHz$	-	70	-	μV_{rms}	
Long Term Stability	$\Delta V_{OUT} / \Delta t$	1		-	22	-	mV/ 1.0kHrs	
Ripple Rejection Ratio	RR	2	$f=120Hz$, $13V \leq V_{IN} \leq 24V$, $T_j=25^{\circ}C$	36	43	-	dB	
Dropout Voltage	$ V_{IN}-V_{OUT} $	1	$T_j=25^{\circ}C$	-	1.7	-	V	
Average Temperature Coefficient of Output Voltage	TC_{VO}	1	$I_{OUT}=5mA$	-	-0.9	-	mV/ $^{\circ}C$	

KIA78S05P~KIA78S24P

ELECTRICAL CHARACTERISTICS

KIA78S12P

(Unless otherwise specified, $V_{IN}=19V$, $I_{OUT}=40mA$, $C_{IN}=0.33\mu F$, $C_{OUT}=0.1\mu F$, $0^{\circ}C \leq T_j \leq 125^{\circ}C$)

CHARACTERISTIC	SYMBOL	TEST CIRCUIT	TEST CONDITION	MIN.	TYP.	MAX.	UNIT	
Output Voltage	V_{OUT}	1	$T_j=25^{\circ}C$	11.5	12	12.5	V	
Input Regulation	Reg line	1	$T_j=25^{\circ}C$	$14.5V \leq V_{IN} \leq 27V$	-	120	250	mV
				$16V \leq V_{IN} \leq 27V$	-	100	200	
Load Regulation	Reg load	1	$T_j=25^{\circ}C$	$1.0mA \leq I_{OUT} \leq 100mA$	-	20	100	mV
				$1.0mA \leq I_{OUT} \leq 40mA$	-	10	50	
Output Voltage	V_{OUT}	1	$14.5V \leq V_{IN} \leq 27V$ $1.0mA \leq I_{OUT} \leq 40mA$	11.4	-	12.6	V	
			$V_{IN}=19V$, $1.0mA \leq I_{OUT} \leq 70mA$	11.4	-	12.6		
Quiescent Current	I_B	1	$T_j=25^{\circ}C$	-	3.2	6.5	mA	
			$T_j=125^{\circ}C$	-	-	6.0		
Quiescent Current Change	ΔI_B	1	$16V \leq V_{IN} \leq 27V$	-	-	1.5	mA	
			$1.0mA \leq I_{OUT} \leq 40mA$	-	-	0.1		
Output Noise Voltage	V_{NO}	1	$T_a=25^{\circ}C$, $10Hz \leq f \leq 100kHz$	-	80	-	μV_{rms}	
Long Term Stability	$\Delta V_{OUT}/\Delta t$	1		-	24	-	mV/ 1.0kHrs	
Ripple Rejection Ratio	RR	2	$f=120Hz$, $15V \leq V_{IN} \leq 25V$, $T_j=25^{\circ}C$	36	41	-	dB	
Dropout Voltage	$ V_{IN}-V_{OUT} $	1	$T_j=25^{\circ}C$	-	1.7	-	V	
Average Temperature Coefficient of Output Voltage	TC_{VO}	1	$I_{OUT}=5mA$	-	-1.0	-	mV/ $^{\circ}C$	

KIA78S05P~KIA78S24P

ELECTRICAL CHARACTERISTICS

KIA78S15P

(Unless otherwise specified, $V_{IN}=23V$, $I_{OUT}=40mA$, $C_{IN}=0.33\mu F$, $C_{OUT}=0.1\mu F$, $0^{\circ}C \leq T_j \leq 125^{\circ}C$)

CHARACTERISTIC	SYMBOL	TEST CIRCUIT	TEST CONDITION	MIN.	TYP.	MAX.	UNIT	
Output Voltage	V_{OUT}	1	$T_j=25^{\circ}C$	14.4	15	15.6	V	
Input Regulation	Reg line	1	$T_j=25^{\circ}C$	$17.5V \leq V_{IN} \leq 30V$	-	130	300	mV
				$20V \leq V_{IN} \leq 30V$	-	110	250	
Load Regulation	Reg load	1	$T_j=25^{\circ}C$	$1.0mA \leq I_{OUT} \leq 100mA$	-	25	150	mV
				$1.0mA \leq I_{OUT} \leq 40mA$	-	12	75	
Output Voltage	V_{OUT}	1	$17.5V \leq V_{IN} \leq 30V$ $1.0mA \leq I_{OUT} \leq 40mA$	14.25	-	15.75	V	
			$V_{IN}=23V$, $1.0mA \leq I_{OUT} \leq 70mA$	14.25	-	15.75		
Quiescent Current	I_B	1	$T_j=25^{\circ}C$	-	3.3	6.5	mA	
			$T_j=125^{\circ}C$	-	-	6.0		
Quiescent Current Change	ΔI_B	1	$20V \leq V_{IN} \leq 30V$	-	-	1.5	mA	
			$1.0mA \leq I_{OUT} \leq 40mA$	-	-	0.1		
Output Noise Voltage	V_{NO}	1	$T_a=25^{\circ}C$, $10Hz \leq f \leq 100kHz$	-	90	-	μV_{rms}	
Long Term Stability	$\Delta V_{OUT} / \Delta t$	1		-	30	-	mV/ 1.0kHrs	
Ripple Rejection Ratio	RR	2	$f=120Hz$, $18.5V \leq V_{IN} \leq 28.5V$, $T_j=25^{\circ}C$	34	40	-	dB	
Dropout Voltage	$ V_{IN}-V_{OUT} $	1	$T_j=25^{\circ}C$	-	1.7	-	V	
Average Temperature Coefficient of Output Voltage	TC_{VO}	1	$I_{OUT}=5mA$	-	-1.3	-	mV/ $^{\circ}C$	

KIA78S05P~KIA78S24P

ELECTRICAL CHARACTERISTICS

KIA78S18P

(Unless otherwise specified, $V_{IN}=27V$, $I_{OUT}=40mA$, $C_{IN}=0.33\mu F$, $C_{OUT}=0.1\mu F$, $0^{\circ}C \leq T_j \leq 125^{\circ}C$)

CHARACTERISTIC	SYMBOL	TEST CIRCUIT	TEST CONDITION	MIN.	TYP.	MAX.	UNIT	
Output Voltage	V_{OUT}	1	$T_j=25^{\circ}C$	17.3	18	18.7	V	
Input Regulation	Reg line	1	$T_j=25^{\circ}C$	$21.4V \leq V_{IN} \leq 33V$	-	32	325	mV
				$22V \leq V_{IN} \leq 33V$	-	27	275	
Load Regulation	Reg load	1	$T_j=25^{\circ}C$	$1.0mA \leq I_{OUT} \leq 100mA$	-	30	170	mV
				$1.0mA \leq I_{OUT} \leq 40mA$	-	15	75	
Output Voltage	V_{OUT}	1		$21.4V \leq V_{IN} \leq 33V$ $1.0mA \leq I_{OUT} \leq 40mA$	17.1	-	18.9	V
				$V_{IN}=27V$, $1.0mA \leq I_{OUT} \leq 70mA$	17.1	-	18.9	
Quiescent Current	I_B	1		$T_j=25^{\circ}C$	-	3.3	6.5	mA
				$T_j=125^{\circ}C$	-	-	6.0	
Quiescent Current Change	ΔI_B	1		$22V \leq V_{IN} \leq 33V$	-	-	1.5	mA
				$1.0mA \leq I_{OUT} \leq 40mA$	-	-	0.1	
Output Noise Voltage	V_{NO}	1	$T_a=25^{\circ}C$, $10Hz \leq f \leq 100kHz$	-	150	-	μV_{rms}	
Long Term Stability	$\Delta V_{OUT} / \Delta t$	1		-	45	-	mV/ 1.0kHrs	
Ripple Rejection Ratio	RR	2	$f=120Hz$, $23V \leq V_{IN} \leq 33V$, $T_j=25^{\circ}C$	32	38	-	dB	
Dropout Voltage	$ V_{IN}-V_{OUT} $	1	$T_j=25^{\circ}C$	-	1.7	-	V	
Average Temperature Coefficient of Output Voltage	TC_{VO}	1	$I_{OUT}=5mA$	-	-1.5	-	mV/ $^{\circ}C$	

KIA78S05P~KIA78S24P

ELECTRICAL CHARACTERISTICS

KIA78S20P

(Unless otherwise specified, $V_{IN}=29V$, $I_{OUT}=40mA$, $C_{IN}=0.33\mu F$, $C_{OUT}=0.1\mu F$, $0^{\circ}C \leq T_j \leq 125^{\circ}C$)

CHARACTERISTIC	SYMBOL	TEST CIRCUIT	TEST CONDITION	MIN.	TYP.	MAX.	UNIT	
Output Voltage	V_{OUT}	1	$T_j=25^{\circ}C$	19.2	20	20.8	V	
Input Regulation	Reg line	1	$T_j=25^{\circ}C$	$23.5V \leq V_{IN} \leq 35V$	-	33	330	mV
				$24V \leq V_{IN} \leq 35V$	-	28	285	
Load Regulation	Reg load	1	$T_j=25^{\circ}C$	$1.0mA \leq I_{OUT} \leq 100mA$	-	33	180	mV
				$1.0mA \leq I_{OUT} \leq 40mA$	-	17	90	
Output Voltage	V_{OUT}	1	$23.5V \leq V_{IN} \leq 35V$ $1.0mA \leq I_{OUT} \leq 40mA$	19.0	-	21.0	V	
			$V_{IN}=29V$, $1.0mA \leq I_{OUT} \leq 70mA$	19.0	-	21.0		
Quiescent Current	I_B	1	$T_j=25^{\circ}C$	-	3.3	6.5	mA	
			$T_j=125^{\circ}C$	-	-	6.0		
Quiescent Current Change	ΔI_B	1	$24V \leq V_{IN} \leq 35V$	-	-	1.5	mA	
			$1.0mA \leq I_{OUT} \leq 40mA$	-	-	0.1		
Output Noise Voltage	V_{NO}	1	$T_a=25^{\circ}C$, $10Hz \leq f \leq 100kHz$	-	170	-	μV_{rms}	
Long Term Stability	$\Delta V_{OUT} / \Delta t$	1		-	49	-	mV/ 1.0kHrs	
Ripple Rejection Ratio	RR	2	$f=120Hz$, $25V \leq V_{IN} \leq 35V$, $T_j=25^{\circ}C$	31	37	-	dB	
Dropout Voltage	$ V_{IN}-V_{OUT} $	1	$T_j=25^{\circ}C$	-	1.7	-	V	
Average Temperature Coefficient of Output Voltage	TC_{VO}	1	$I_{OUT}=5mA$	-	-1.7	-	mV/ $^{\circ}C$	

KIA78S05P~KIA78S24P

ELECTRICAL CHARACTERISTICS

KIA78S24P

(Unless otherwise specified, $V_{IN}=33V$, $I_{OUT}=40mA$, $C_{IN}=0.33\mu F$, $C_{OUT}=0.1\mu F$, $0^{\circ}C \leq T_j \leq 125^{\circ}C$)

CHARACTERISTIC	SYMBOL	TEST CIRCUIT	TEST CONDITION	MIN.	TYP.	MAX.	UNIT	
Output Voltage	V_{OUT}	1	$T_j=25^{\circ}C$	23	24	25	V	
Input Regulation	Reg line	1	$T_j=25^{\circ}C$	$27.5V \leq V_{IN} \leq 38V$	-	35	350	mV
				$28V \leq V_{IN} \leq 38V$	-	30	300	
Load Regulation	Reg load	1	$T_j=25^{\circ}C$	$1.0mA \leq I_{OUT} \leq 100mA$	-	40	200	mV
				$1.0mA \leq I_{OUT} \leq 40mA$	-	20	100	
Output Voltage	V_{OUT}	1	$27.5V \leq V_{IN} \leq 38V$ $1.0mA \leq I_{OUT} \leq 40mA$	22.8	-	25.2	V	
			$V_{IN}=33V$, $1.0mA \leq I_{OUT} \leq 70mA$	22.8	-	25.2		
Quiescent Current	I_B	1	$T_j=25^{\circ}C$	-	3.5	6.5	mA	
			$T_j=125^{\circ}C$	-	-	6.0		
Quiescent Current Change	ΔI_B	1	$28V \leq V_{IN} \leq 38V$	-	-	1.5	mA	
			$1.0mA \leq I_{OUT} \leq 40mA$	-	-	0.1		
Output Noise Voltage	V_{NO}	1	$T_a=25^{\circ}C$, $10Hz \leq f \leq 100kHz$	-	200	-	μV_{rms}	
Long Term Stability	$\Delta V_{OUT}/\Delta t$	1		-	56	-	mV/ 1.0kHrs	
Ripple Rejection Ratio	RR	2	$f=120Hz$, $29V \leq V_{IN} \leq 39V$, $T_j=25^{\circ}C$	31	35	-	dB	
Dropout Voltage	$ V_{IN}-V_{OUT} $	1	$T_j=25^{\circ}C$	-	1.7	-	V	
Average Temperature Coefficient of Output Voltage	TC_{VO}	1	$I_{OUT}=5mA$	-	-2.0	-	mV/ $^{\circ}C$	

KIA78S05P~KIA78S24P

TEST CIRCUIT / STANDARD APPLICATION CIRCUIT

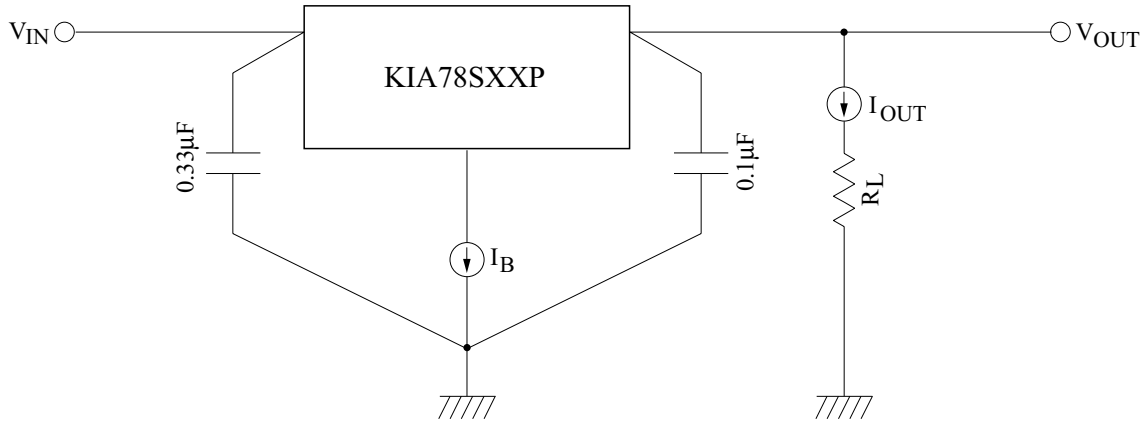

TEST CIRCUIT

1. V_{OUT} , $R_{eg} \cdot line$, $R_{eg} \cdot load$, V_{OUT} , I_B , ΔI_B , V_{NO} , $DV_{OUT} / \Delta t$, $|V_{IN} - V_{OUT}|$, TC_{VO}

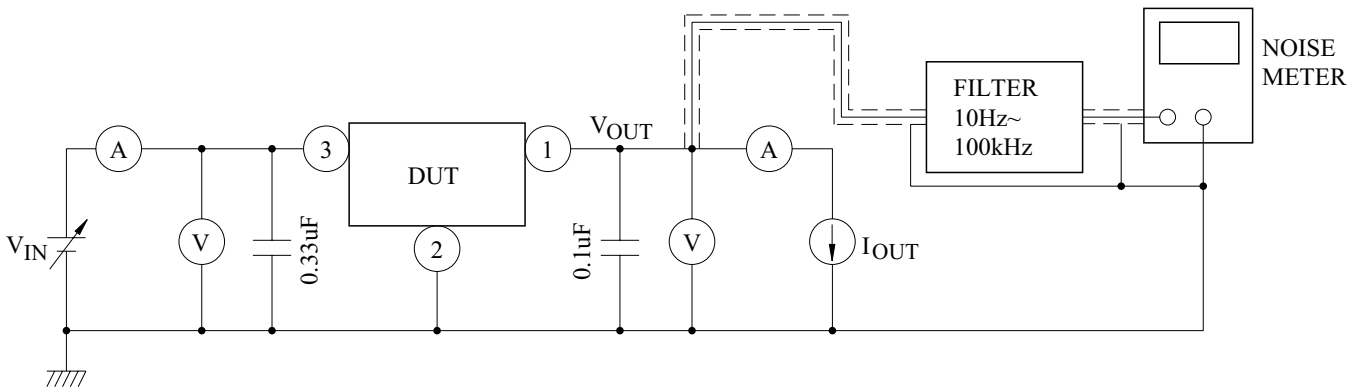

2. RR

$$e_i = 1V_{p-p}$$

$$f = 120Hz$$

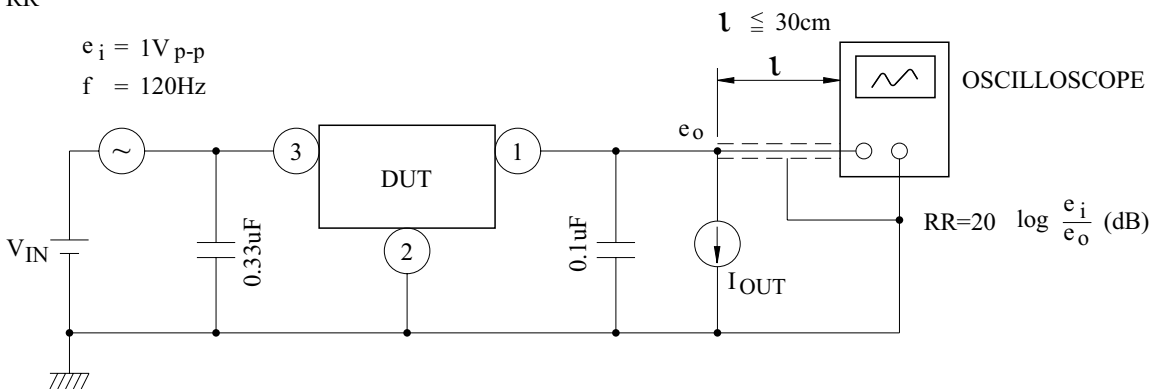

KIA78S05P~KIA78S24P

APPLICATION CIRCUIT

(1) STANDARD APPLICATION

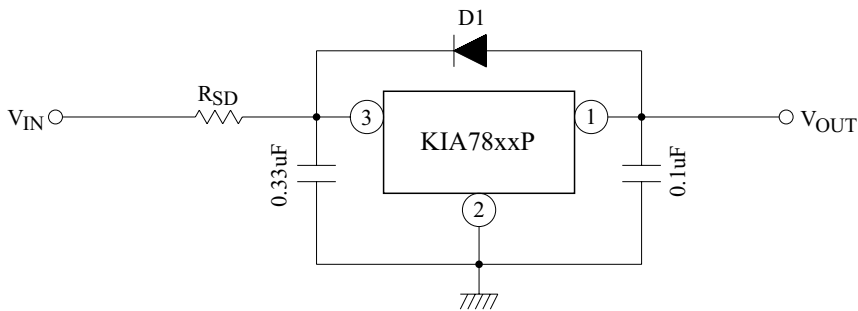

D1 : Protection Diode
High speed diode D1 should be connected as shown in the figure if the condition $V_{IN} < V_{OUT}$ might occur by surge voltage or power supply ON/OFF.

R_{SD} : Power limiting resistor for large V_{IN} , resistor R_{SD} is needed to limit IC power dissipation.

(2) A. CURRENT BOOST VOLTAGE REGULATOR

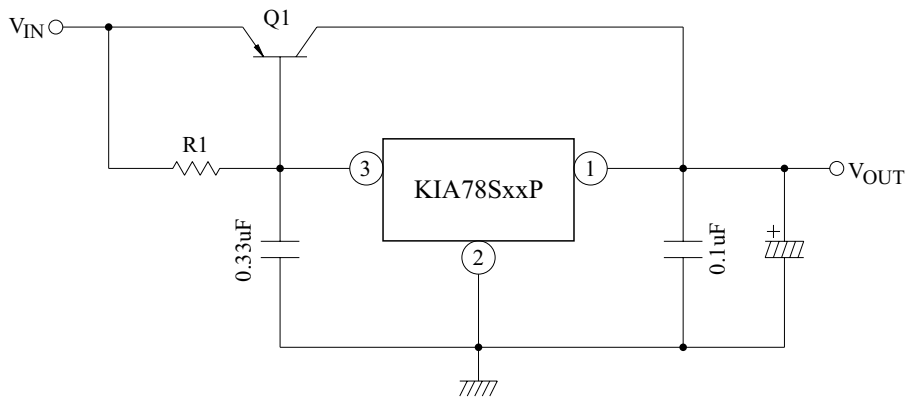

Heat sink is needed for Q1

$$R1 \leq \frac{V_{BE1}}{I_{B(MAX)}}$$

where, V_{BE1} : V_{BE} of external transistor Q1

$I_{B(MAX)}$: Quiescent current of IC

B. SHORT-CIRCUIT PROTECTION

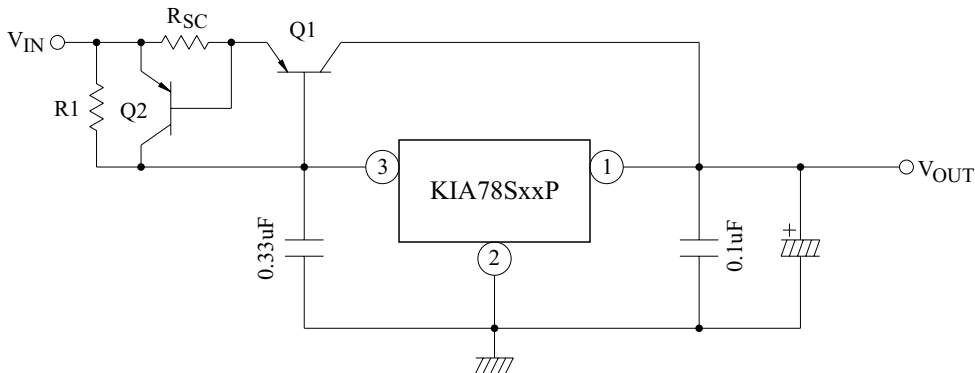

$$R_{SC} = \frac{V_{BE2}}{I_{SC}}$$

where, I_{SC} : Short-Circuit current

(3) CURRENT REGULATOR

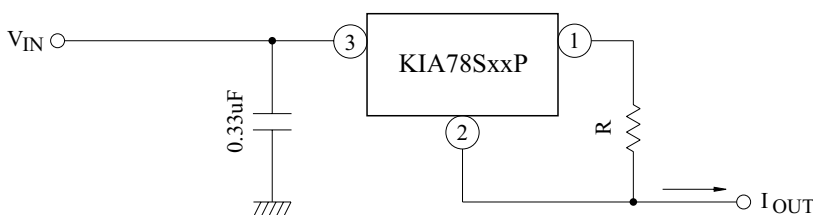

$$I_{OUT} = \frac{V_{OUT}}{R} + I_B$$

KIA78S05P~KIA78S24P

(4) VOLTAGE BOOST REGULATOR

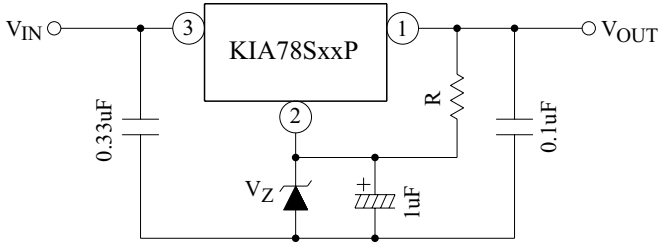

$V_{OUT} = V_Z + V_{OUT} \text{ (of IC)}$
 A little of current in resistor R is needed.

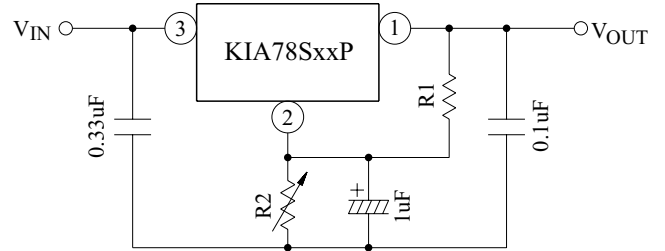

$$V_{OUT} = R_2 \left(I_B + \frac{V_{OUT} \text{ (of IC)}}{R_1} \right) + V_{OUT} \text{ (of IC)}$$

(5) NEGATIVE REGULATOR

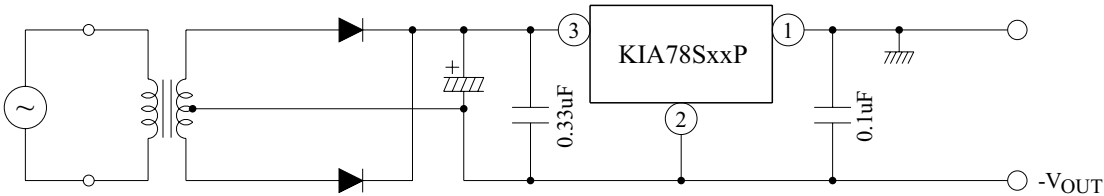

(6) POSITIVE AND NEGATIVE REGULATOR

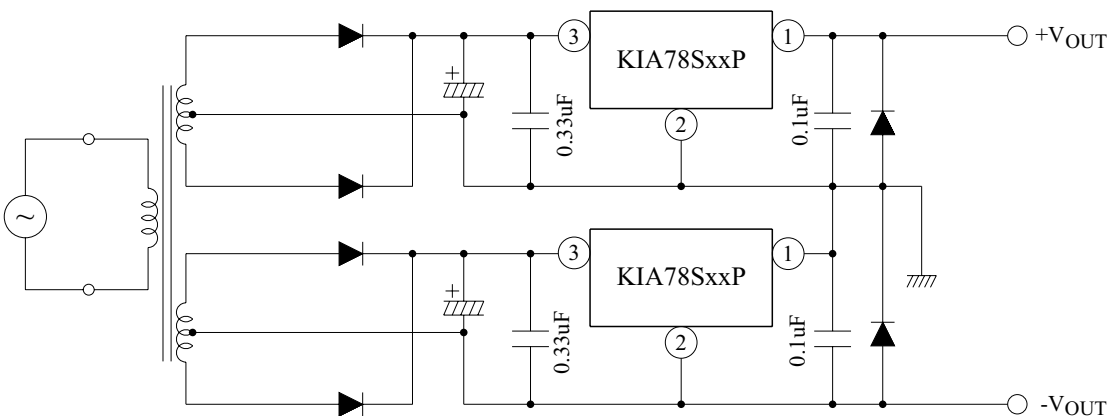

KIA78S05P~KIA78S24P

PRECAUTIONS FOR USE

When such a high voltage as exceeds 10V beyond the fixed output voltage (Typ. Value) of IC is applied to the output terminal of IC, the IC may be destroyed. In such a case, it is advised to prevent an excessive voltage from being applied to the IC by connecting a zener diode between the output terminal and the GND. Especially, in the current boost circuit as shown in example (2) of application circuits, an input voltage may be suddenly applied to the output terminal of IC in the form of steps, and that in case of light load, an excessive voltage may be transiently applied to the output terminal of IC: So that great care should be taken to this matter. In this case, in addition to the above, it may become necessary to consider such a countermeasure as the output capacitor in use is replaced with a capacitor of larger capacitance, or as R1 (a resistor for IC bias current) or bypass is replaced with a resistor of smaller resistance according to circumstances, or as the input voltage is gradually raised.

KIA78S05P~KIA78S24P

