

ISS.	DATE	E.C.N.	DESCRIPTION
1	31-May-07		FIRST ISSUE
2	30-Aug-07		DIM A TABLE VALUES
3	04-Oct-07		CLIP TOLERANCES MODIF'D 27 VDI FINISH TO FRONT
4	29-May-08	05/08/1224	IMPROVED FIT WITH OPTIC MOULDING
5	21-Jan-09		SHEET 2 ADDED - PCB POSITION
6	12-Mar-09	03/09/1242	DRAWING TITLE CHANGED
7	01-Mar-10	03/10/1265	CLEAR PART NO.'S ADDED TO TABLE AND MOVED TO SHEET 4

  
 technical plastics  
**CARCLO TECHNICAL PLASTICS (SLOUGH)**  
 111 BUCKINGHAM AVE, SLOUGH  
 SL1 4PF, ENGLAND  
 TEL: +44 1753 575011 FAX: +44 1753 811359  
 email: design@carclo-optics.com

GENERAL TOLERANCES (UNLESS STATED)

	LINEAR		ANGULAR
X	+/- 0.25	X	+/- 1°
X.X	+/- 0.1	X.X	+/- 0.5°
X.XX	+/- 0.05	X.XX	+/- 0.1°

CUSTOMER

TITLE

50mm TRIPLE HOLDER

DRAWN	MK	DATE	31-May-07
-------	----	------	-----------

CHK'D	MB	DATE	03-Mar-10
-------	----	------	-----------

APP'D	PW	DATE	03-Mar-10
-------	----	------	-----------

SCALE	1:1	CARCLO PART No.	SEE TABLE ON SHEET 4
-------	-----	-----------------	----------------------

SIZE	A3	CARCLO DRG. No.	60443	SHEET	1 OF 3
------	----	-----------------	-------	-------	--------

ISS.	DATE	E.C.N.	DESCRIPTION
7	01-Mar-10	03/10/1265	CLEAR PART NO.'S ADDED TO TABLE AND MOVED TO SHEET 4

© 2006 CARCLO  
ALL DIMENSIONS IN mm

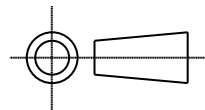

CARCLO TECHNICAL PLASTICS (SLOUGH)  
111 BUCKINGHAM AVE, SLOUGH  
SL1 4PF, ENGLAND  
TEL: +44 1753 575011 FAX: +44 1753 811359  
e-mail: design@carclo-optics.com

GENERAL TOLERANCES (UNLESS STATED)

LINEAR	ANGULAR
X +/- 0.25	X +/- 1°
X.X +/- 0.1	X.X +/- 0.5°
X.XX +/- 0.05	X.XX +/- 0.1°

CUSTOMER

CARCLO

TITLE

50mm TRIPLE HOLDER

DRAWN

MKI

DATE

21-Jan-09

CHK'D

MB

DATE

03-Mar-10

APP'D

PW

DATE

03-Mar-10

SCALE

2:1

CARCLO PART No.

SEE TABLE ON SHEET 4

SIZE

A4

CARCLO DRG. No.

60443

SHEET

2 OF 3

PCB LAYOUT DIAGRAM

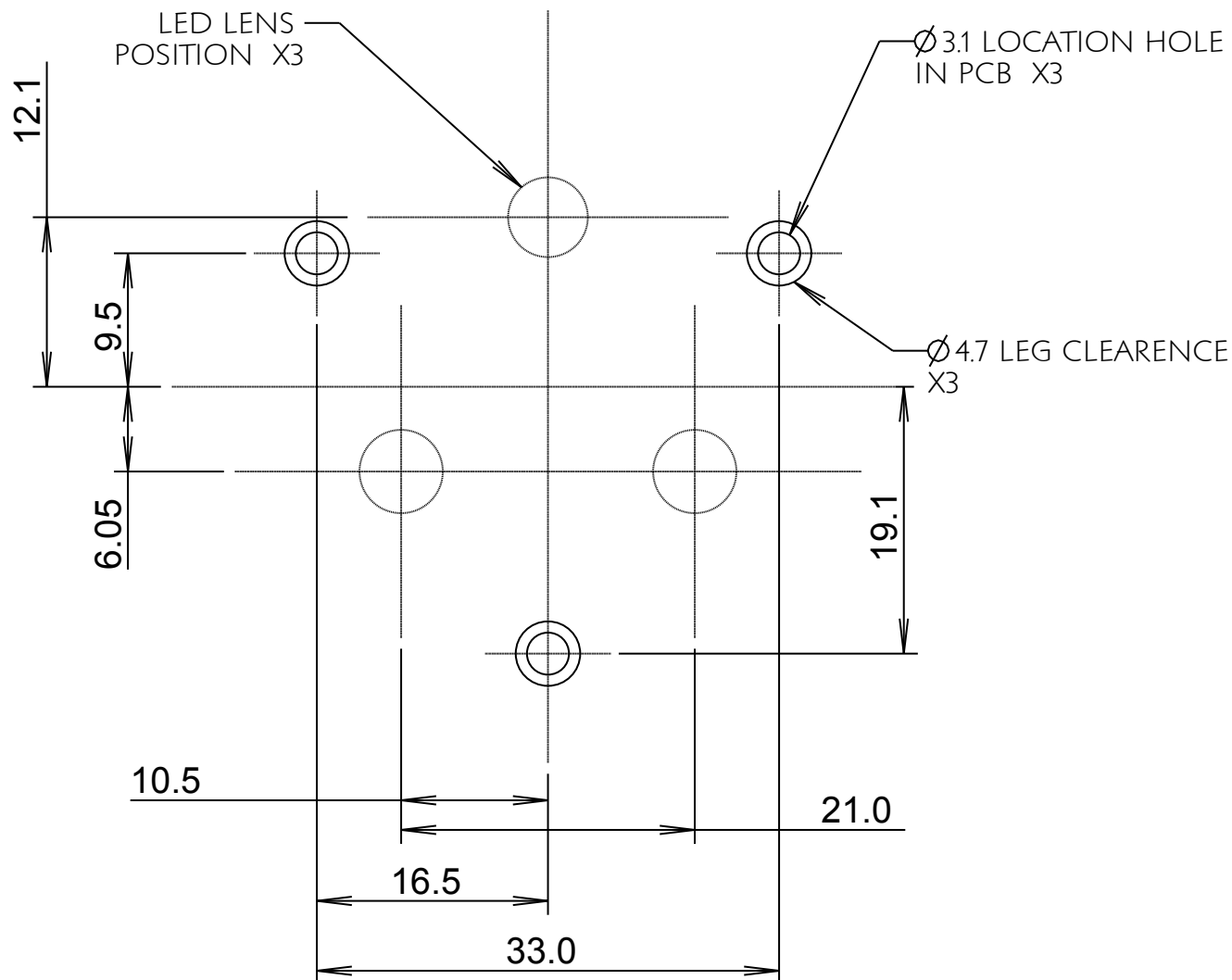

ISS.	DATE	E.C.N.	DESCRIPTION
7	01-Mar-10	03/10/1265	CLEAR PART NO.'S ADDED TO TABLE AND MOVED TO SHEET 4

© 2006 CARCLO  
ALL DIMENSIONS IN mm

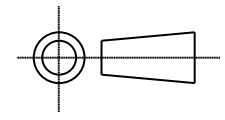

**CARCLO TECHNICAL PLASTICS (SLOUGH)**  
111 BUCKINGHAM AVE, SLOUGH  
SL1 4PF, ENGLAND  
TEL: +44 1753 575011 FAX: +44 1753 811359  
e-mail: design@carclo-optics.com}

NOT ALL PARTS ARE AVAILABLE FROM STOCK.  
SOME PARTS ARE SPECIAL ORDER ONLY. PLEASE  
CONTACT CARCLO FOR CURRENT AVAILABILITY

GENERAL TOLERANCES (UNLESS STATED)

LINEAR	ANGULAR
X +/- 0.25	X +/- 1°
X.X +/- 0.1	X.X +/- 0.5°
X.XX +/- 0.05	X.XX +/- 0.1°

**PART NO.S**

DIM A	4.3 mm PIN WHITE	0.8mm PIN WHITE	4.3mm PIN BLACK	0.8mm PIN BLACK	4.3 mm PIN CLEAR	0.8mm PIN CLEAR
14.0	10270	10280	10290	10300	12000	12010
13.8	10271	10281	10291	10301	12001	12011
13.6	10272	10282	10292	10302	12002	12012
13.4	10273	10283	10293	10303	12003	12013
13.2	10274	10284	10294	10304	12004	12014
13.0	10275	10285	10295	10305	12005	12015
12.8	10276	10286	10296	10306	12006	12016
12.6	10277	10287	10297	10307	12007	12017
12.4	10278	10288	10298	10308	12008	12018
12.2	10279	10289	10299	10309	12009	12019

CUSTOMER

CARCLO

TITLE

50mm TRIPLE HOLDER

DRAWN

MB

DATE

01-Mar-10

CHK'D

BB

DATE

03-Mar-10

APP'D

PW

DATE

03-Mar-10

SCALE

1:1

CARCLO PART No.

SEE TABLE

SIZE

A4

CARCLO DRG. No.

60443

SHEET

3 OF 3