

REV	DESCRIPTION	APPROVAL	DATE
F	新制定		06.04.14

REV.	DESCRIPTION	DATE
F	MODIFY TABLE Δ x4	06/15/04

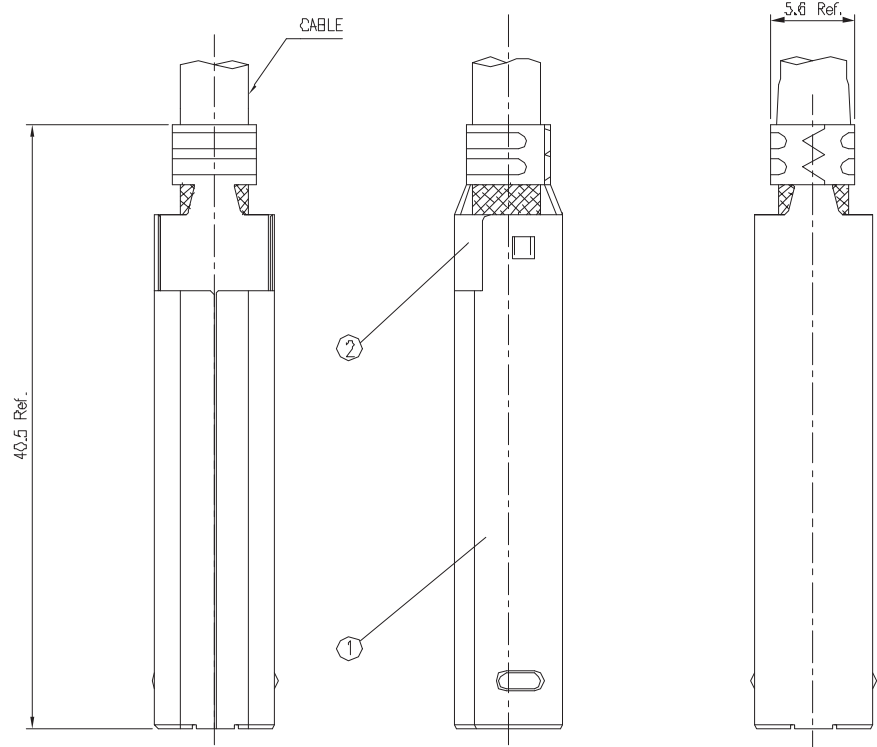

NOTES :

- 1.0. RATING :
- 1.1. VOLTAGE : 30 VAC (R.M.S.)
 - 1.2. CURRENT : 1.5A MAXIMUM
 - 1.3. TEMPERATURE : -55°C TO +85°C UNLESS LIMITED BY CABLE OR OVERMOLD (-40°C TO +60°C STORAGE ;+0°C TO +40°C OPERATING)

- 2.0. ELECTRIC CHARACTERISTIC :
- 2.1. CONTACT RESISTANCE : 3D MILLIOHMS MAXIMUM INITIAL
 - 2.2. INSULATION RESISTANCE : 1,000 MEGOHMS MINIMUM
 - 2.3. DIELECTRIC WITHSTANDING VOLTAGE : 750 VAC AT SEE LEVER
 - 2.4. CAPACITANCE : 2 PICO FARADS MAXIMUM AT 1KHZ

- 3.0. MATERIALS :
- 3.1. FRONT & REAR SHELL : STEEL
 - 3.2. HOUSING : THERMOPLASTIC, GLASS FILLED, UL 94V-0 RATED
 - 3.3. CONTACT : COPPER ALLOY

- 4.0. FINISHS :
- 4.1. FRONT & REAR SHELL :
 TIN/COPPER: 2.5-5.0um Min TIN; 2.5um Min COPPER
 NICKEL: 3.0um-5.0um NICKEL OVER 2.5um Min. COPPER
 GOLD: 1.5u*Min. GOLD ; 5.0um Min. NICKEL ; 2.5um Min. COPPER
 - 4.2. CONTACT : REFER DRAWING NO.: CT-UAC1D-DD-00
- 5.0. OTHERS :
- 5.1. RECOMMENDED CABLE APPLICATION :
 OUTER DIAMETER APPLICABLE RANGE : ϕ 3.4mm TO ϕ 5.3mm
 - 5.2. ALL PARTS PACKAGED UNASSEMBLED

ITEM	NAME	QTY	MATERIAL / FINISH
3	HOUSING WITH CONTACT	1	SEE NOTE 3.2.; 3.3.; 4.2.
2	REAR SHELL	1	SEE NOTE 3.1.; 4.1.
1	FRONT SHELL	1	SEE NOTE 3.1.; 4.1.

ROHS-COMPLIANT

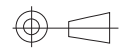
 貝強實業有限公司 PANSTRONG COMPANY LTD.				DRAWN BY		TOMMY	
				CHECKED			
TITLE:		HARDWARE KAS, PLUG 4 POSITION, SERIES B, SOLDER TYPE				APPROVED	
PART NO:		USB4M01W05S				DRAW NO	
DRAW. BOX NO:							
SCALE		3:1	REV	F	UNIT	mm	

7	8	9	10	11
REV	DESCRIPTION	APPROVAL	DATE	
F	新制定		06.04.14	

PART NO. TABLE

USBB4M 01 W 05 S
 1 2 3 4 5

1. USB B, 4 POS. PLUG
2. 01: SOLDER TYPE
02: CRIMP TYPE
3. W : WHITE K: BLACK
4. PLATING ON CONTACT:
05: 5u" 30: 30u"
5. SHORT BODY

ASSEMBLY PROCESS:
SCALE 1:1

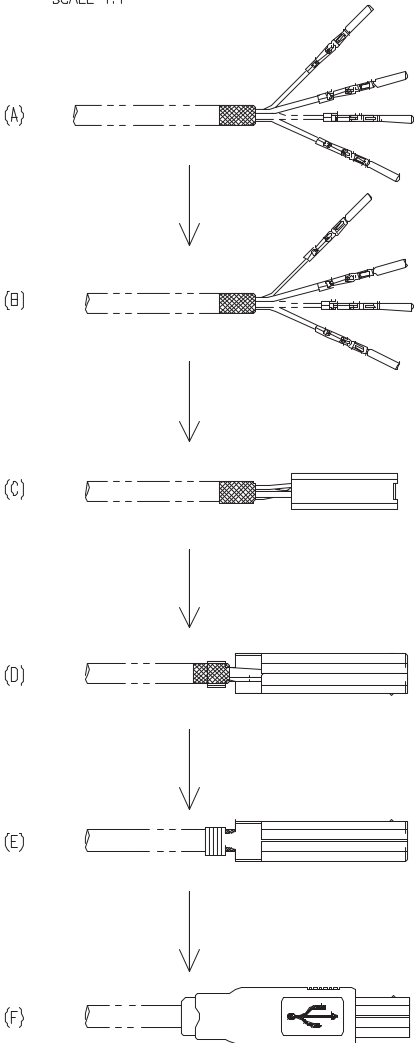

PART:

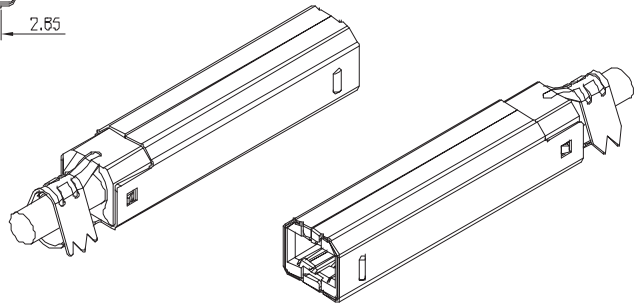
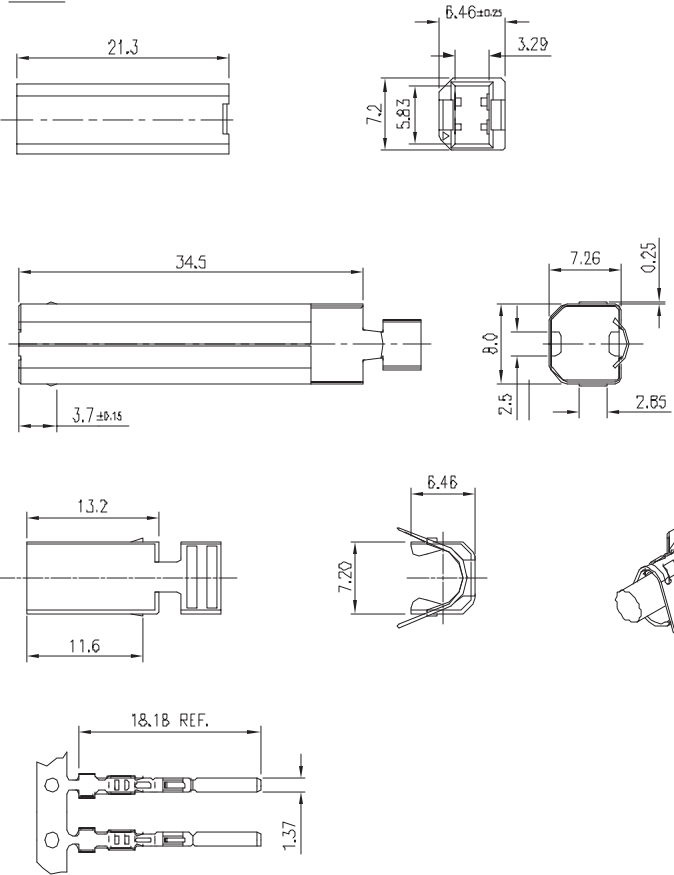

ROHS-COMPLIANT

	貝強實業有限公司 PANSTRONG COMPANY LTD.			DRAWN BY	TOMMY
	TITLE: HARDWARE KAS, PLUG 4 POSITION, SERIES B, SOLDER TYPE			CHECKED	
PART NO: USBB4M01W05S			APPROVED		
DRAW. BOX NO:			DRAW NO		
SCALE	3:1	REV	F	UNIT	mm