



Measurement Mode	Auto	Manual	Control Range	Initial Range
mA (DC/AC)	R1 – R2	R1 → R2, R2 → R1	40.00mA – 400.0mA	40.00mA
A (DC/AC)	fixed	fixed	40.00A	40.00A
Ω	OR1 – OR6	OR _i → OR _i + 1, OR6 → OR1	400.0 Ω – 40.00M Ω	400.0 Ω
Capacitance	C1 – C8	C _i → C _i + 1, C8 → C1	4.000nF – 40.00mF	4.000nF
Continuity	fixed	fixed	400.0 Ω	400.0 Ω
Diode	fixed	fixed	4.000V	4.000V
Frequency	FR1 – FR6	FR _i → FR _i + 1, FR6 → FR1	4.000KHz – 400.0MHz	4.000KHz
RPM	RP1 – RP6	RP _i → RP _i + 1, RP6 → RP1	40.00KRPM – 4000MRPM	40.00KRPM

Note: Pushing RANGE resets all existing special modes except for VAHZ mode.

3.8 KEY

See Section “Measurement Mode Switching” for the function of this pin.

4 Serial Data Output

The serial data is sent to SDO pin twice every A/D conversion cycle. The data format complies with JIS 7BIT transmission code with a baud rate of 2400. The host can use RS-232 interface to read the data. A single data packet includes a start bit (always 0), 7 data bits, an odd parity check bit, and a stop bit (always 1). The following figure shows the data format of a single packet. The LSB is sent first and the MSB is sent last.



One data block consists of 11 packets, or 110 bits. The following figure shows the format of a data block. The range packet indicates the full scale range of the meter. Digit 3 through digit 0 is just the digits on the LCD panel. The function packet indicates the measurement mode of the meter. Status, option 1 and option 2 gives the status of the meter. CR and LF are delimiters used to separate the blocks.

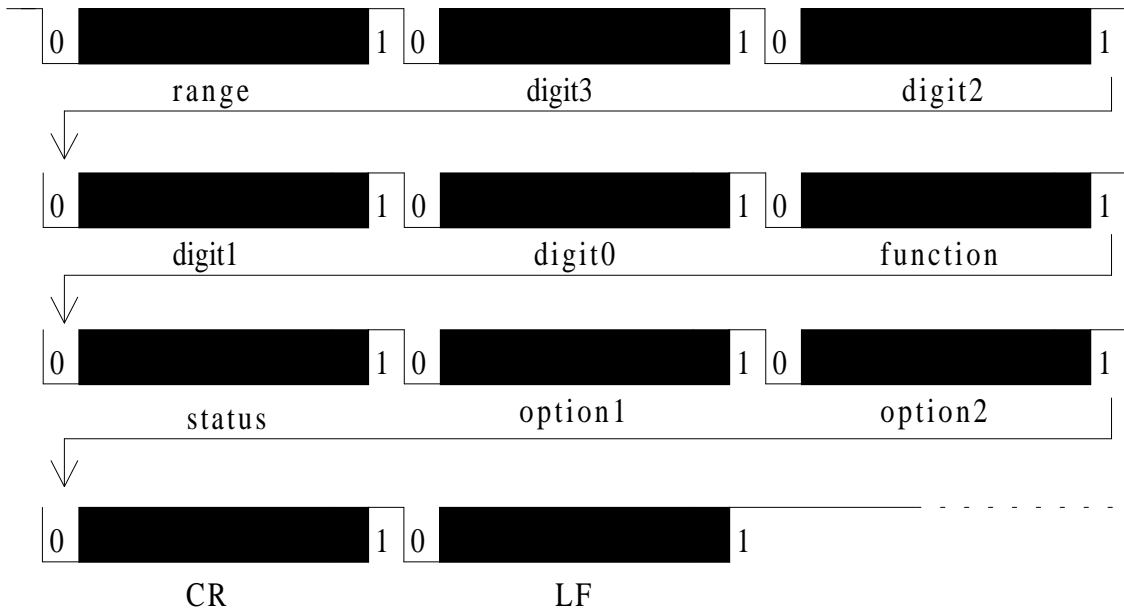

The meter always outputs the current input value to the serial port. Each block is repeated twice in one conversion cycle. The detailed data format of each packet is listed below.

4.1 FUNCTION

This packet indicates the measurement mode of the meter. The following table summarizes the transmitted code for each mode. Note that the encoding of this packet is different from the encoding of FC1-FC4 switch.

Code	Measurement Mode
0111011	Voltage
0111101	μ A Current
0111001	mA Current
0111111	A Current
0110011	Ω
0110101	Continuity
0110001	Diode
0110010	Frequency / RPM ¹
0110110	Capacitance
0110100	Temperature ²
0111110	ADP0
0111100	ADP1
0111000	ADP2
0111010	ADP3

Note:

1. The Judge bit in the Status packet determines whether it is frequency mode or RPM mode.
2. The Judge bit in the Status packet determines whether the unit is Celcius or Fahrenheit.

4.2 RANGE

This packet indicates the full scale range of the meter. When the meter operates in continuity mode, diode mode, or current (A) mode, this packet is always 0110000 since the full scale range in these modes are fixed. The following table lists the code for each range in each measurement mode.



Code	V	mA	μ A	Ω	Frequency	RPM	Capacitance
0110000	400.0mV	40.00mA	400.0 μ A	400.0 Ω	4.000KHz	40.00KRPM	4.000nF
0110001	4.000V	400.0mA	4000 μ A	4.000K Ω	40.00KHz	400.0KRPM	40.00nF
0110010	40.00V			40.00K Ω	400.0KHz	4.000MRPM	400.0nF
0110011	400.0V			400.0K Ω	4.000MHz	40.00MRPM	4.000 μ F
0110100	4000V			4.000M Ω	40.00MHz	400.0MRPM	40.00 μ F
0110101				40.00M Ω	400.0MHz	4000MRPM	400.0 μ F
0110110							4.000mF
0110111							40.00mF

4.3 DIGIT 3 – DIGIT 0

Digit 3 is the most significant digit on the LCD panel, and digit 0 is the least significant digit. When the LCD panel shows OL, the serial port outputs 4000.

Digit	Code
0	0110000
1	0110001
2	0110010
3	0110011
4	0110100
5	0110101
6	0110110
7	0110111
8	0111000
9	0111001

4.4 STATUS

The format of this packet is shown below. The Judge field is meaningful only when the Function packet indicates Frequency/RPM mode or Temperature mode. In Temperature mode, judge is 1 if the unit is $^{\circ}C$ and is 0 if the unit is $^{\circ}F$. In Frequency/RPM mode, judge is 1 if the meter operates in RPM mode; otherwise, it is 0. Sign field indicates whether the minus sign on the LCD panel is on or off. BATT field is one if battery low condition is true. OL indicates input overflow.

0	1	1	Judge	Sign	BATT	OL
Bit 6	Bit 5	Bit 4	Bit 3	Bit 2	Bit 1	Bit 0

4.5 OPTION 1

This packet contains information on special measurement modes. The format of this packet is shown below. The three non-constant fields is set to one when the meter operates in the corresponding special modes.

0	1	1	P_{MAX}	P_{MIN}	0	VAHZ
Bit 6	Bit 5	Bit 4	Bit 3	Bit 2	Bit 1	Bit 0

4.6 OPTION 2

This packet contains information on the operation mode of the meter. The format is shown below. The DC field indicates that the meter operates in DC measurement mode, either voltage or current. The AC field indicates



that the meter operates in AC measurement mode. The AUTO field is set to one if the meter operates in automatic mode, and is set to zero when the meter operates in manual mode. The APO field indicates whether auto power off function is enabled or not.

0	1	1	DC	AC	AUTO	APO
Bit 6	Bit 5	Bit 4	Bit 3	Bit 2	Bit 1	Bit 0

4.7 CR

Carrage return. The transmitted code is 0001101.

4.8 LF

Line feed. The transmitted code is 0001010.

5 Miscellaneous

5.1 The Buzzer

The conditions which the meter turns on the buzzer include:

- (1) Changing measurement mode generates one beep.
- (2) Pressing any of the push functions generates one beep, if the function is valid.
- (3) Power on and re-power on generate one beep.
- (4) Input overflow in voltage and current mode generates one beep every 0.3 seconds (or 3.33 beeps per second.)
- (5) Continuity check generates a continuous 2KHz beep whenever the measurement is less then 35Ω.
- (6) Auto power off generates a 2KHz beep which lasts for 1.5 seconds.

The following figures shows the output waveform from the BUZOUT pin.

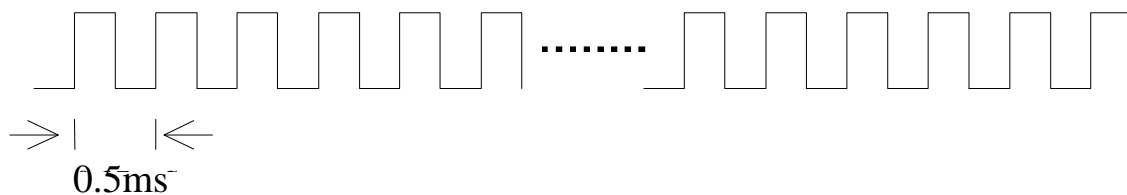

(a) Continuous 2KHz beep

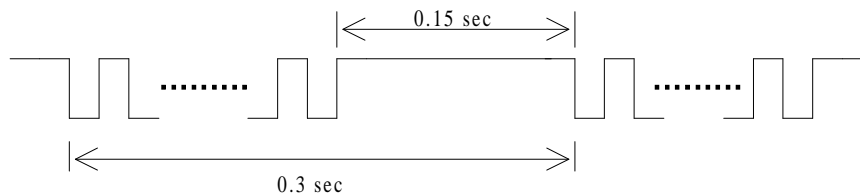

(b) 3.33 beep/sec



5.2 LCD Pin Assignment

	SEG1	SEG2	SEG3	SEG4	SEG5	SEG6	SEG7	SEG8	SEG9	SEG10
BP1	bar40	bar37	bar36	m ₂	bar33	bar32	bar29	bar28	bar25	bar24
BP2	bar39	bar38	Hz	bar35	bar34	bar31	bar30	bar27	bar26	1 _d
BP3	F	°F		°C	Ω	u ₂	K	M	1 _c	1 _g
BP4	A	V	m ₁	P _{MIN}	u ₁	n		P _{MAX}	1 _b	1 _a

	SEG11	SEG12	SEG13	SEG14	SEG15	SEG16	SEG17	SEG18
BP1	bar22	bar21	bar19	bar18	bar16	bar15	bar13	bar12
BP2	bar23	P1	bar20	2 _d	bar17	P2	bar14	3 _d
BP3	1 _e	RPM	2 _c	2 _g	2 _e	MANU	3 _c	3 _g
BP4	1 _f	MIN	2 _b	2 _a	2 _f	MAX	3 _b	3 _a

	SEG19	SEG20	SEG21	SEG22	SEG23	SEG24	SEG25	SEG26
BP1	bar10	bar9	bar7	bar6	bar4	bar3	bar1	bar0
BP2	bar11	bar8	P3	4 _d	bar5	bar2	APO	bar-
BP3	3 _e	AUTO	4 _c	4 _g	4 _e	RS232	DC	-
BP4	3 _f	REL	4 _b	4 _a	4 _f	HOLD	BATT	AC

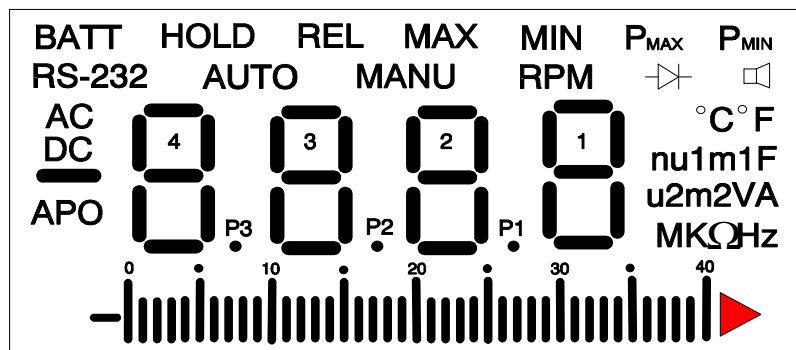



5.3 LCD Backplane Waveform

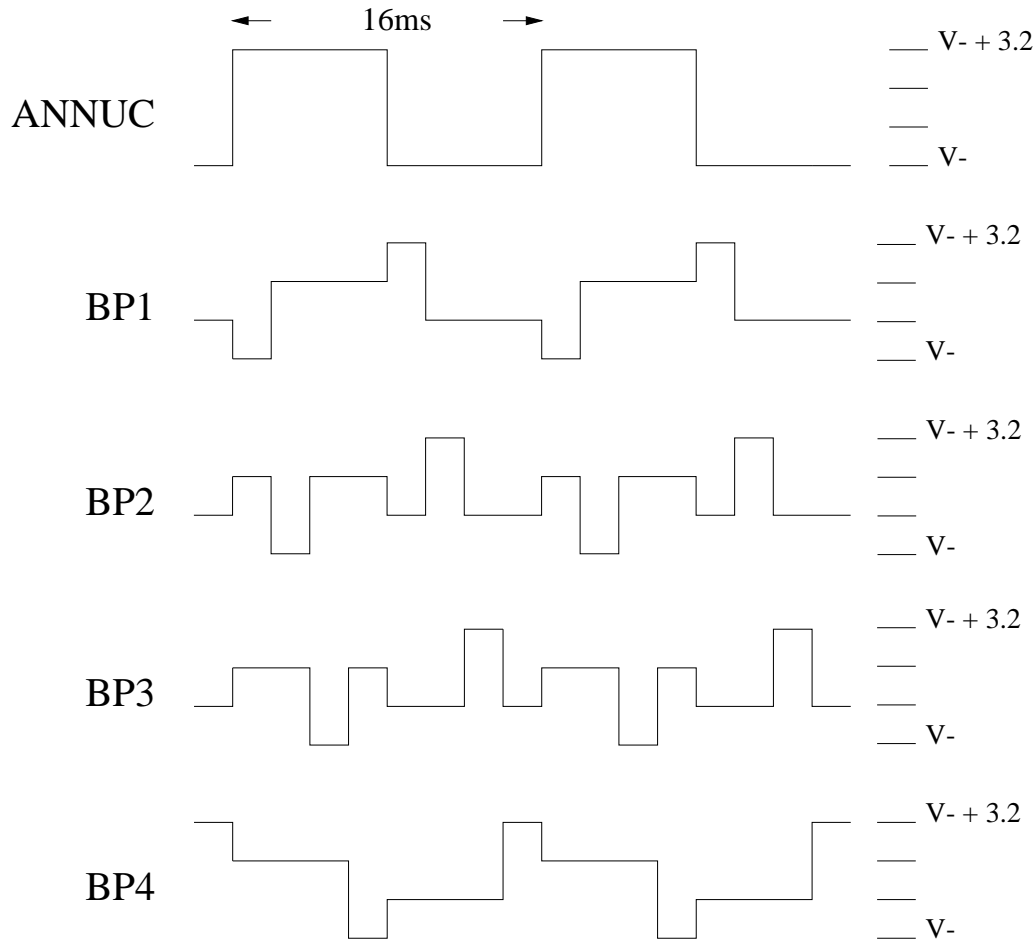

5.4 LCD Display On Condition

LCD Annunciator	Condition
V	In voltage measurement mode and diode measurement mode.
A	In current measurement mode.
Ω	In resistance measurement mode and continuity check mode.
F	In capacitance measurement mode.
	In continuity check mode.
	In diode mode.
Hz	In frequency mode, VAHZ mode.
DC	In DC voltage or DC current mode.
AC	In AC voltage or AC current mode.
AUTO	When automatic full scale range selection is enabled.
MANU	In manual mode.
HOLD	When HOLD function is enabled.
REL	When REL function is enabled. When the LCD displays the reference value, REL blinks.