



3D Printer User Manual

V1.1

To Our Dear Users

Thank you for choosing Creality. For your convenience, please read through this User Manual before you start and follow the instructions provided carefully.

Creality is always ready to provide you with high-quality services. If you encounter any issues or have any questions when using our products, please use the contact information at the end of this manual to contact us. To further improve your user experience, you can find more about our devices via the following methods:

User manual: You can find instructions and videos in the memory card provided with the printer.

You can also visit our official website (<https://www.creality.com>) to find information regarding software, hardware, contact information, device instructions, device warranty information, and more.

Firmware Upgrade

Please visit our official website <https://www.creality.com/download>. Click Homepage → Support → Download.

Download the required firmware and install it.

- 1 Do not use this printer by methods or operations that are not described in this manual, otherwise it may result in accidental injury or property damage.
- 2 Do not place this printer near flammable materials, explosive materials or high heat sources. Please place this printer in a ventilated, cool and low-dust environment.
- 3 Do not place this printer in a vibrating or any other unstable environment, as the printing quality will be compromised when the printer shakes.
- 4 Please use the filament recommended by the manufacturer, otherwise the nozzle may be clogged or the printer may be damaged.
- 5 Please use the power cord provided with the printer and do not use the power cord of other products. The power plug must be plugged into a three-hole socket with a ground wire.
- 6 Do not touch the nozzle or hotbed while the printer is in operation, otherwise you may get burned.
- 7 Do not wear gloves or accessories while operating the printer, otherwise the moving parts may cause accidental injury including cuts and lacerations.
- 8 After the printing process is complete, please use tools to clean up the filament on the nozzle while the nozzle is still hot. Do not touch the nozzle with your hands when cleaning, otherwise your hands may get burned.
- 9 Please regularly clean the printer body with a dry cloth while the power is off, and wipe off dust, sticky printing materials, and foreign objects on the guide rails.
- 10 Children under the age of 10 must not use this printer without adult supervision in order to avoid accidental injury.
- 11 This printer has a safety protection mechanism. Please do not manually move the nozzle or printing platform quickly while the printer is on, otherwise the printer will automatically power off for protection.
- 12 Users should abide by the laws and regulations of the corresponding country and region where the equipment is located (place of use), abide by professional ethics, and pay attention to safety obligations. The use of our products or equipment for any illegal purpose is strictly prohibited. Our company is not responsible for the relevant legal responsibilities of any violators.

About the Printer	01-01
Device Specifications	02-02
List of Parts	03-03
Installing the 3D Printer	04-07
Using the 3D Printer	08-12
First Printing	13-13
Circuit Wiring	14-14

1. About the Printer

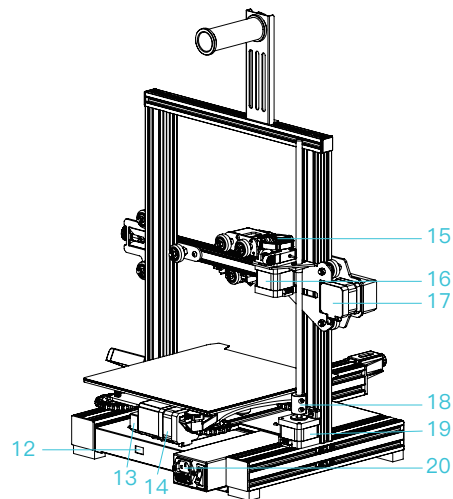
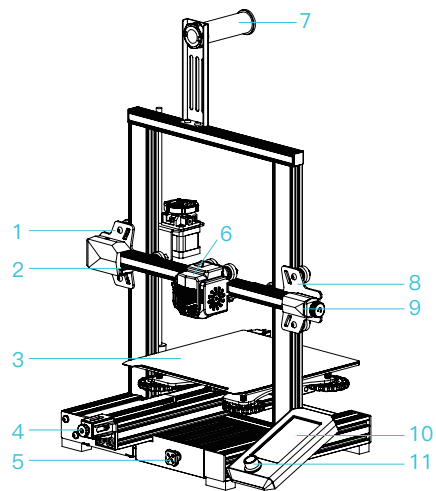

1 XE-axis component

2 X-axis limit switch

3 Printing platform

4 Y-axis tensioner

5 Tool box

6 Nozzle kit

7 Material rack and material barrel

8 Z-axis passive block

9 X-axis tensioner

10 Display screen

11 Rotary switch

12 Voltage regulation gear

13 Y-axis limit switch

14 Y-axis motor

15 Indication knob

16 E-axis motor

17 X-axis motor

18 Coupler

19 Z-axis motor

20 Power switch and socket

2. Device Specifications

General Specifications	
Product model	Ender-3 V2 Neo
Modeling dimensions	220*220*250mm
Molding tech	FDM
Number of nozzles	1
Slice height	0.1mm-0.4mm
Nozzle diameter	Standard 0.4mm
Precision	±0.1mm
Filament	PLA/PETG/ABS
Supported file format	STL/OBJ/AMF
Print Method	USB/storage card
Supported slice software	Creality Slicer/Creality Print/Cura/Repetier-Host/Simplify3D
Input voltage	100-120V~, 200-240V~, 50/60Hz
Rated power	350W
Hotbed temperature	≤100°C
Nozzle temperature	≤250°C
Power loss recovery	Yes
Auto leveling	Yes
Switch languages	中文/ English
Operating system	Windows XP/Vista/7/10/MAC/Linux
Printing speed	≤ 120 mm/s, generally 50 mm/s

3. List of Parts

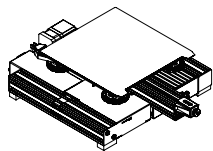

1 Base Frame Package

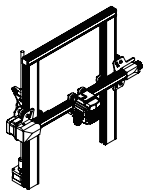

2 Gantry Frame

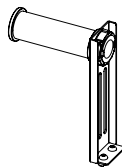

3 Material Rack and Barrel Assembly

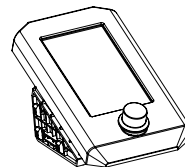

4 Display Screen Component



List of Accessory Kit Item

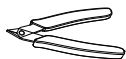

5 Cutting Plier



6 Wire Clip (Blue)

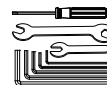

7 Wrench and Screwdriver



8 Power Cable



9 Nozzle Cleaner



10 Storage Card & Card Reader



11 Nozzle



12 Filament (20mm)



13 M5x45 Hexagon Socket Head Spring Washer Combination Screw x 5



14 Indication Knob



15 Quick Release Claw



16 Black tie x 5

Note: The components above are for reference only. The actual product may vary.

4. Installing the 3D Printer

4.1 Gantry Frame Installation

- A. Move the profile on the right side of the bottom component 35 mm away from the desktop, so that the mounting hole is exposed on the desktop.
- B. Place the gantry frame in the slot of the base frame, and pre-lock it with two M5x45 hexagon socket head spring washer combination screws from the bottom to the top.
- C. Rotate the bottom component by 180° to ensure that the profiles on both sides are level. Use two M5x45 hexagon socket head spring washer combination screws to align the holes on the left side to pre-lock the holes first, and then tighten to fix them.
- D. Rotate the bottom component by 180°, and tighten the screw on the right side.

To tighten the screw, put the short side of the wrench into the screw and secure it.

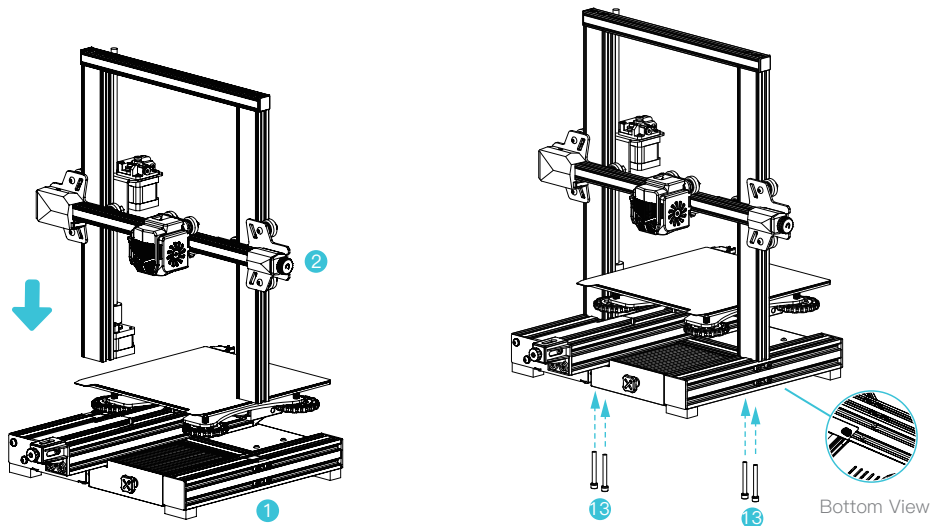

4. Installing the 3D Printer

4.2 Installing display screen

- Place the display screen assembly on the side of the right profile, snap it into the profile in parallel and tighten the screws;
- Connect the display screen wiring.

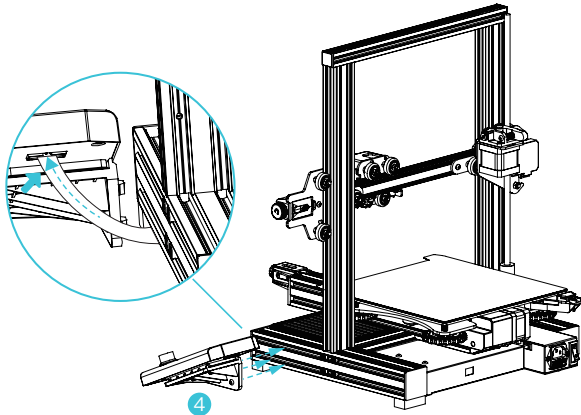

4.3 Installing material rack

- Fix the material rack and barrel assembly to the profile, as shown in the diagram below.

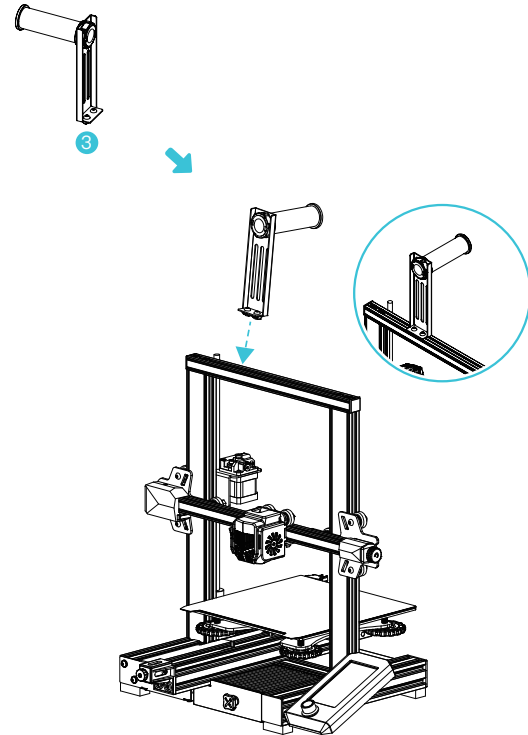

4. Installing the 3D Printer



4.4 Cable Connection



6pin (4 wires)



X, E, Z-axis motor port



3pin (2 wires)



X-axis limit switch

- A. Put the indication knob directly onto the motor shaft;
- B1. Follow the yellow label on the 6pin (4 wires) port to connect the X-axis stepper motor;
- B2. Follow the yellow label on the 6pin (4 wires) port to connect the E-axis stepper motor;
- B3. Follow the yellow label on the 6pin (4 wires) port to connect the Z-axis stepper motor;
- C. Follow the yellow label on the 3pin (2 wires) port to connect the X axis limit switch;
- D. Plug in the power cord and toggle the switch to turn on the power.

Caution

- Please ensure the correct position for the power supply switch and mains before supply connection, in order to avoid damage to the device.
- If the mains between 100V and 120V, please select the 115V for the power supply switch.
- If the mains between 200V and 240V, please select the 230V for the power supply switch (default is 230V).

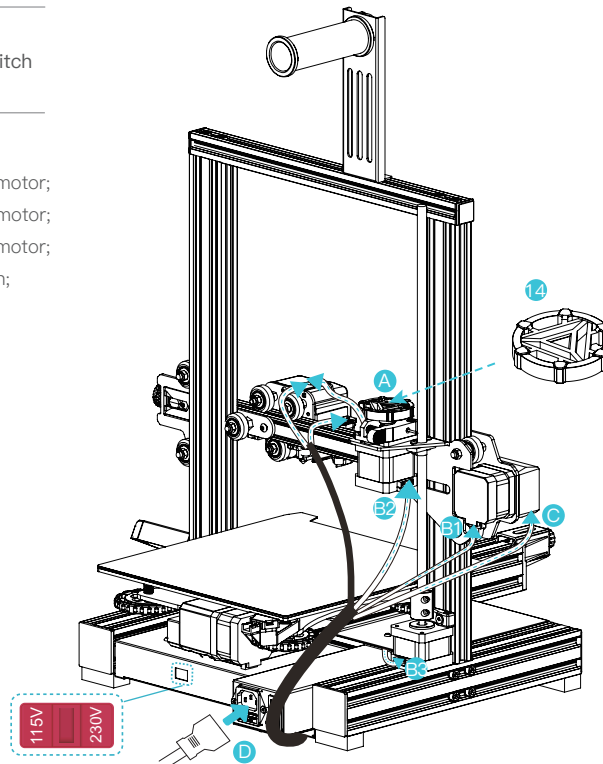

4. Installing the 3D Printer

4.5 Adjusting pulley tightness

- A. Check the pulley looseness before switching on the machine.

X/Y/Z axis pulley adjustment: Gently turn the pulley to check whether it is idling or jammed. If this phenomenon occurs, use an open-end wrench to adjust the tightness of the hexagonal eccentric isolation column to make it rotate smoothly.

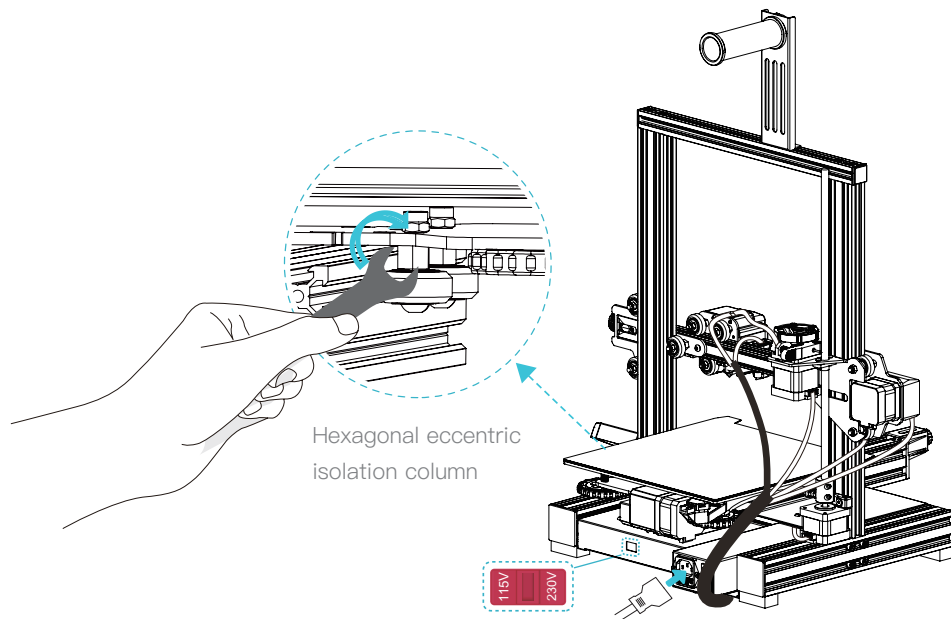

5. Auxiliary levelling



5.1 Go to “Control → Reset configuration” to reset the printer parameters.

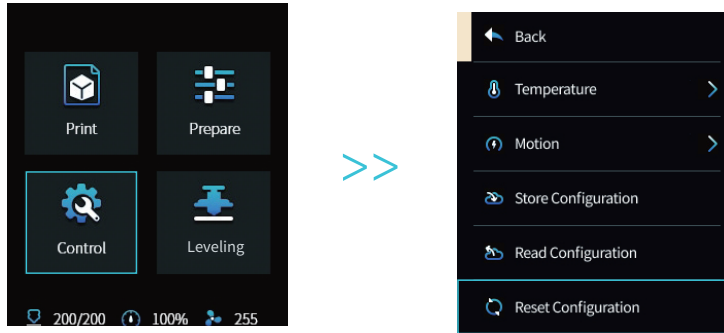

5.2 Go to “Prepare → Auto home” to return to the starting position.

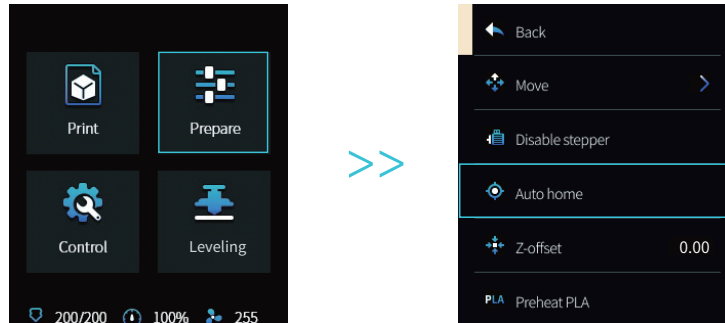

5. Auxiliary levelling

5.3 Go to “Prepare → Move → Move Z” and reset.

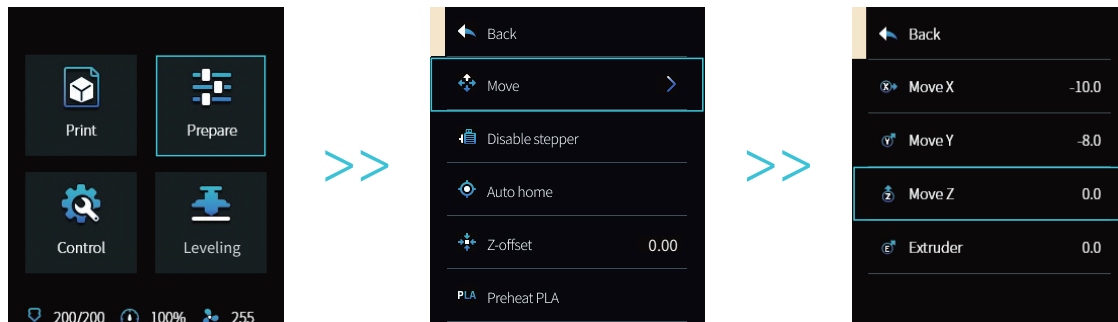

5.4 Go to “Prepare → Z–offset”, adjust the Z–axis compensation value so that the height of the nozzle to the platform is almost the thickness of A4 paper (0.08–0.1mm); then, click the knob, and the central point leveling is done.

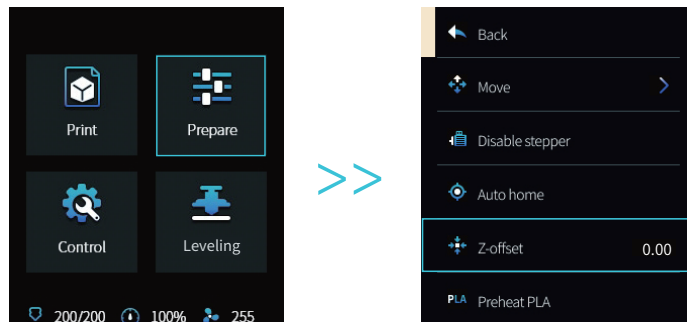

5. Auxiliary levelling

5.5 Go to “Prepare → Disable stepper” to switch off all motor enables.

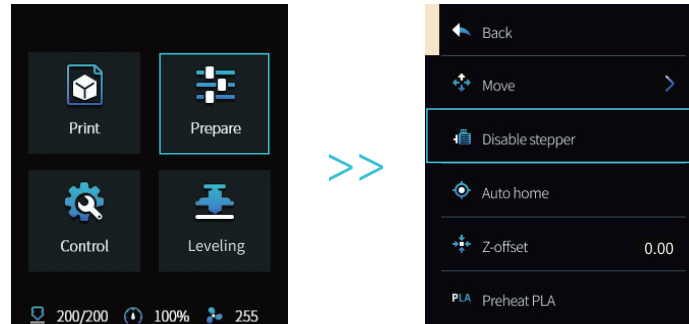

5.6 Adjust the knob at the bottom of the hotbed and move the nozzle to the four corners of the printing platform, respectively, so that the height of the nozzle to the printing platform is approximately the thickness of A4 paper (0.08–0.1mm). Make sure that the four corners are properly leveled.

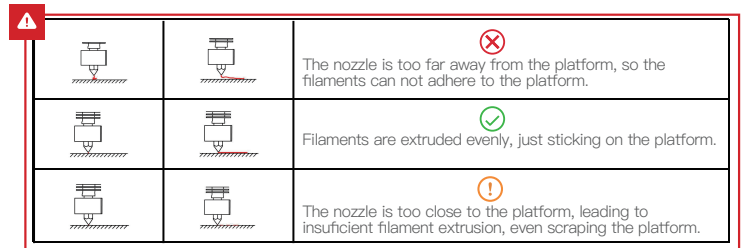
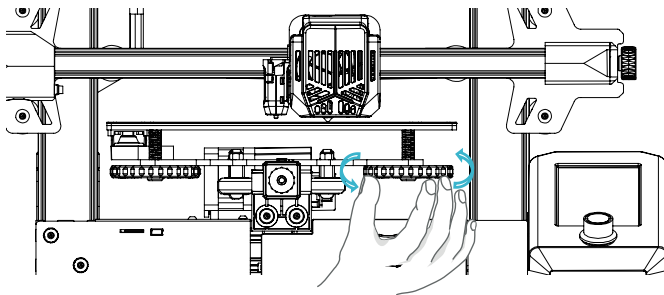

6. Auto Leveling

6.1 Power up the appliance and select “Leveling”

Default: After the printer has first automatically returned to the home position for auto-calibration, and after 16 points of data calibration, the printer will return to the home position again and the levelling process is complete.

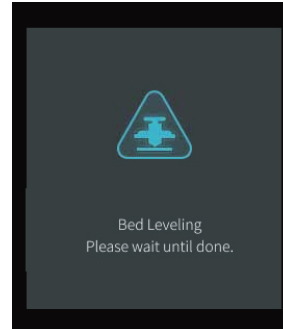
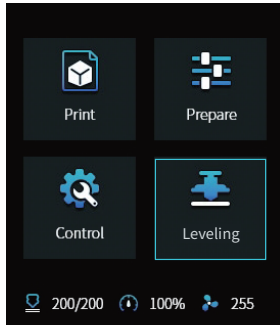

6.2 Go to “Prepare → Z–offset”, adjust the Z–axis compensation value so that the height of the nozzle to the printing platform is about the thickness of a piece of A4 paper (0.08–0.1mm); then, click the knob and the Z–axis compensation value is thus successfully determined.

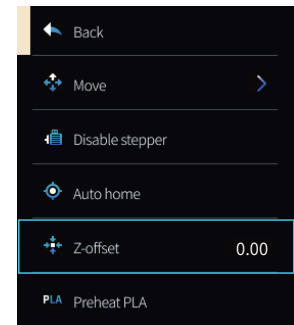
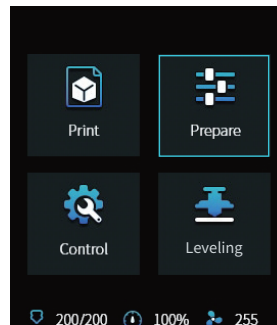
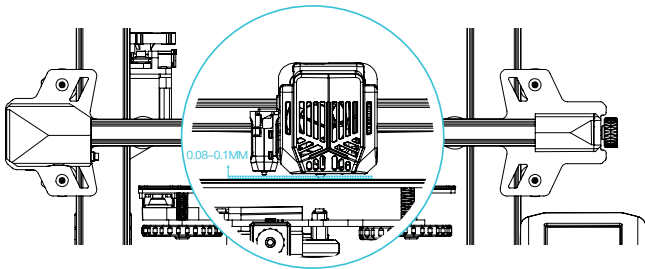

7. Load Filaments

7.1 When you wait for the temperature to rise, hang the filament over the filament rack.

7.2 Press the extrusion clamp and insert the filaments along the extruder hole up to the nozzle. When the temperature hits the target value, a flow of filaments can be seen at the nozzle, meaning that the filaments have been loaded.

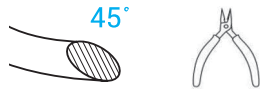
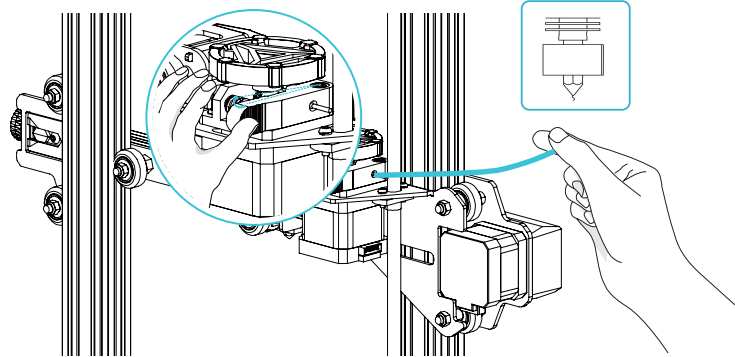
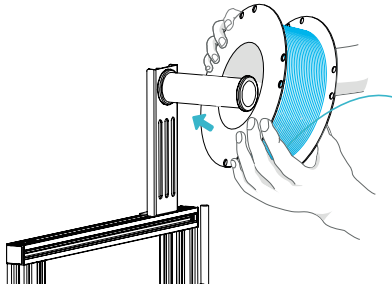

For smoother printing, the end of the filament should be cut as shown above.



Replacement of filaments:

1. When the printer is not under work:

- A. Heat the nozzle to above 185°C first, wait for the filaments inside the nozzle to soften, then press the extrusion handle and pull out the filaments quickly to prevent them from getting stuck at the heat break;
- B. Replace the new filaments onto the material rack and repeat the loading procedure in 7.

2. When the printer is working:

- A. Suspend printing first and, once the printer has stopped, press the extrusion handle to pull the filaments out quickly and prevent them from getting stuck at the heat break;
- B. Replace the new filaments onto the material rack, press the extrusion handle, insert the filaments through the extruder feed hole into the nozzle, then push the filaments hard to squeeze out the residual filaments from the nozzle, and clean it up for printing.

8. First Printing



8.1 Download from www.creality.com, or find the Creality software on your memory card and install it.

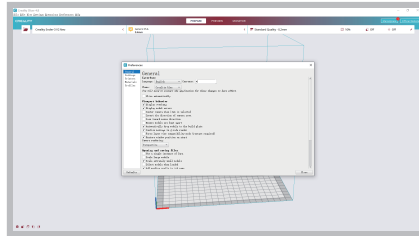

8.2 Go to Preferences → Basic → Select Language → Finish to complete the settings.

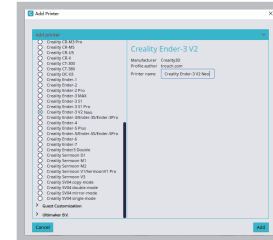

8.3 Select the model of the printer (Ender-3 V2 Neo).

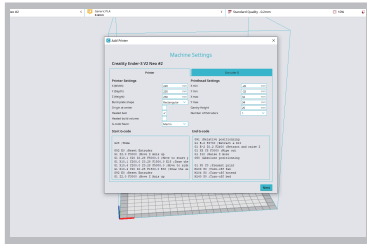

8.4 Enter Parameters → Close.



8.5 Launch the Creality Slicing Software.

8.6 Load the file.

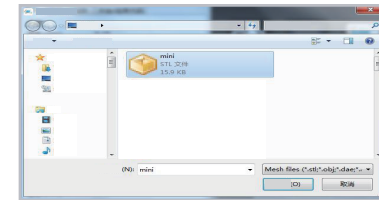

8.7 Select the file.

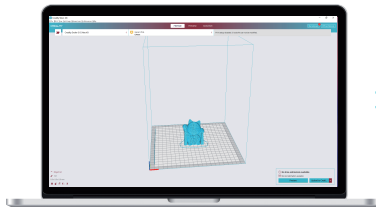

8.8 Generate the G-code file → Save it to the memory card.

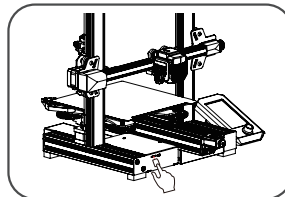

8.9 Insert the memory card → Press the screen knob → Select from the menu → Select the used for printing.



The file name must only contain Latin letters and digits. Chinese characters or special symbols must not be used.



Note: For details on using the software, please refer to the slicing software user manual in the storage card.

9. Circuit Wiring

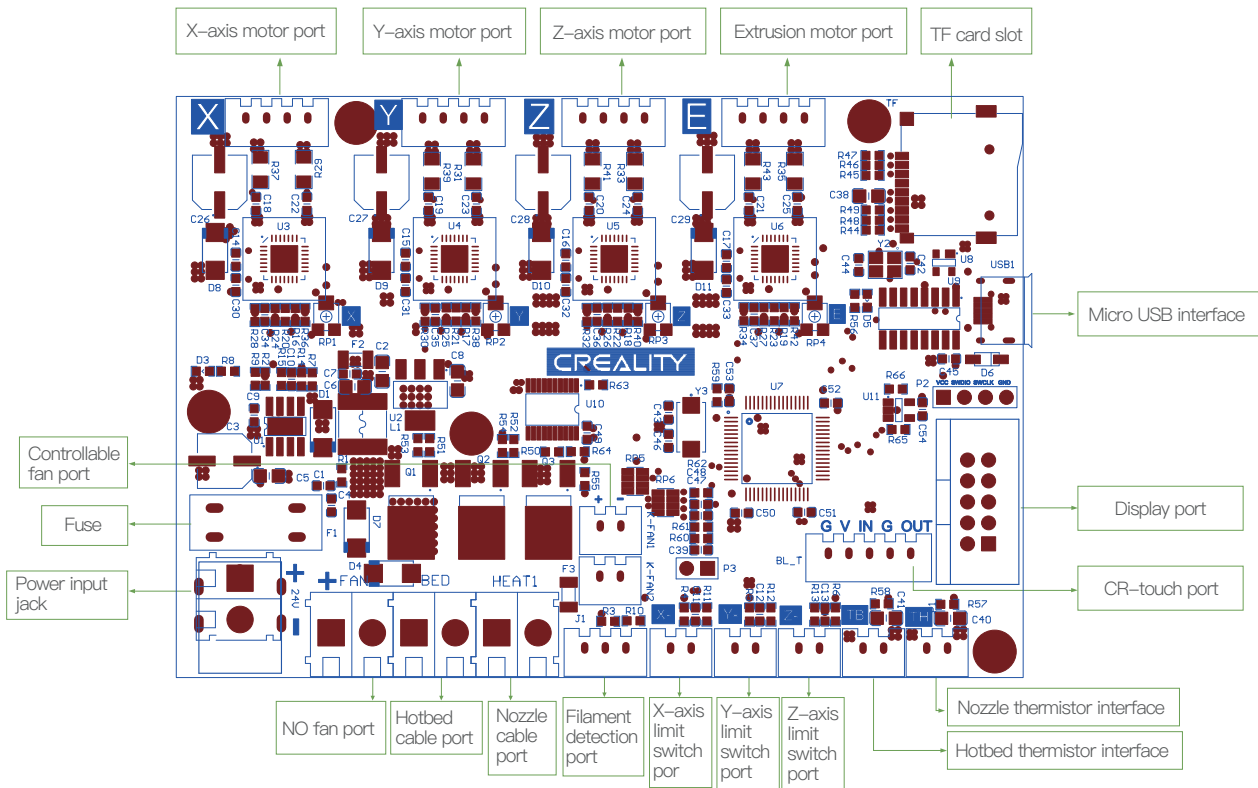

Since each model is different, the actual product may be different from the picture. Please refer to the actual product.
The final interpretation right belongs to Shenzhen Creality 3D Technology Co., Ltd.



SHENZHEN CREALITY 3D TECHNOLOGY CO.,LTD.

18F, JinXiuHongDu Building, Meilong Blvd., Longhua Dist., Shenzhen,
China 518131

Official Website: www.creality.com

Tel: +86 755-8523 4565

E-mail: info@creality.com cs@creality.com

