

AnkerMake

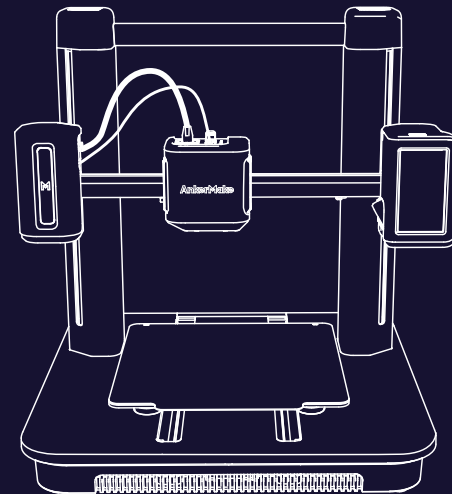

Anker Innovations Limited. All rights reserved. AnkerMake and AnkerMake Logo are trademarks of Anker Innovations Limited, registered in the United States and other countries. All other trademarks are the property of their respective owners.

51005003445 V01

AnkerMake M5
QUICK START GUIDE

English	001
Deutsch	026
Español	049
Français	072
Italiano	095
Nederlands	118
Português	141
日本語	164
한국어	184
ةيبرعل	207

AT A GLANCE

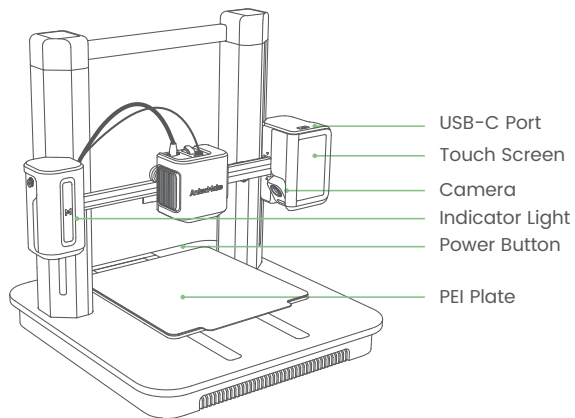

Indicator Light*	Description
Flashing Orange Slowly	Heating up
Fading Green Repeatedly	Printing
Flashing Red	An alarm is going off

* For more indicator light status, visit <https://www.ankermake.com>.
 Product Name: AnkerMake M5 Model: V8111

ASSEMBLING THE PRINTER

What You Need

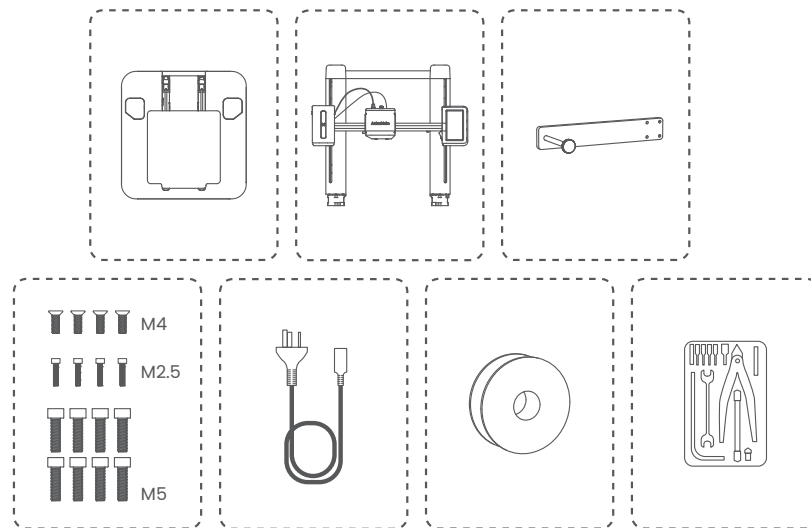

Step 1. Installing Gantry Frame

1. Open the box, then place the foam cover on the ground.

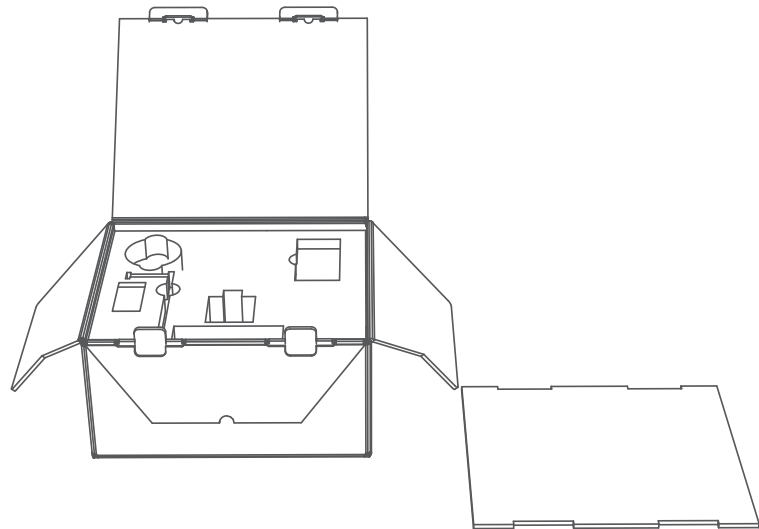

2. Take out all the accessories in the foam, then place the protection foam on the ground as support.

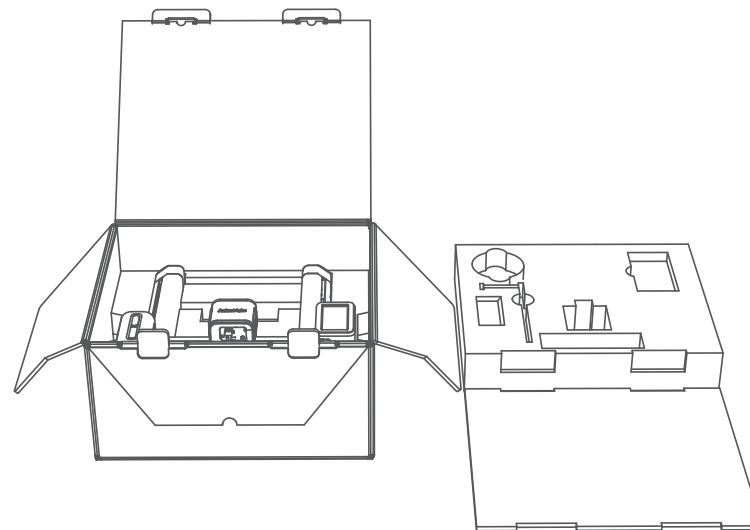

3. Take out the gantry frame with its protection foam and place it on the support foam.

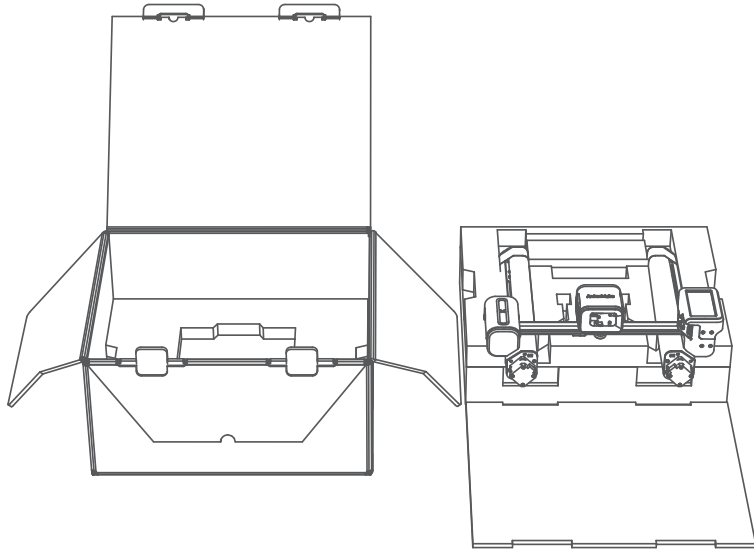

4. Take the gantry frame out of the packaging foam, then put it back as shown below.

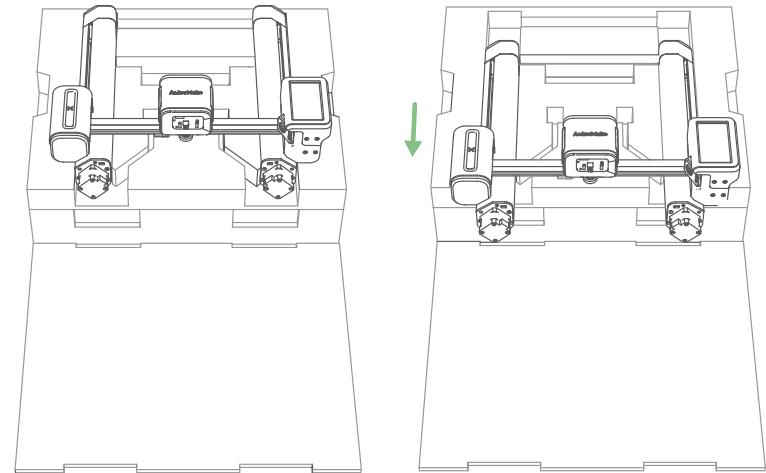

5. Detach the bottom cover from the platform.

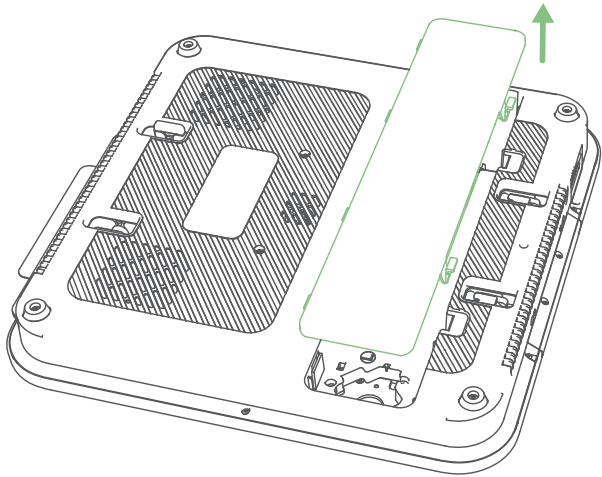

6. Mount the platform through the holes.

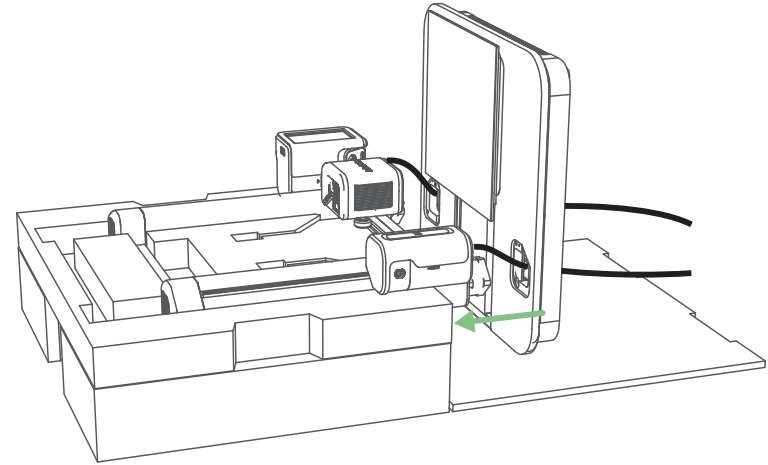

7. Fasten screws into the platform.

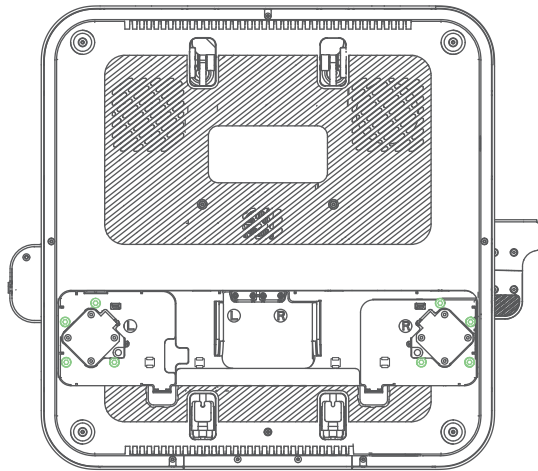

⊙ M5

Step 2. Wiring

1. Connect the motor wires.

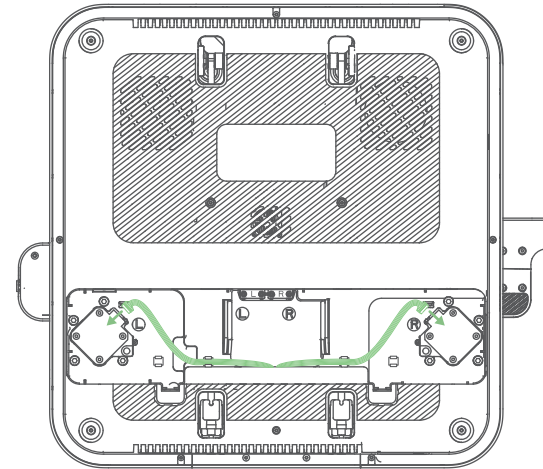

2. Connect and fix the USB-C cables with screws.

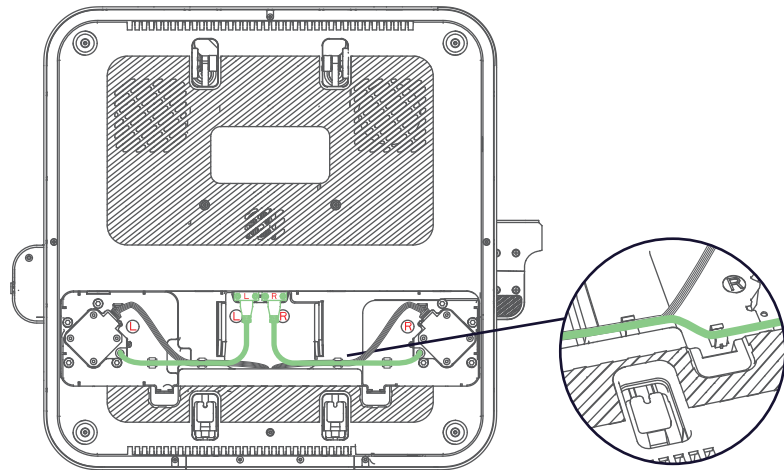

Ⓜ M2.5

3. Put the bottom cover back onto the platform.

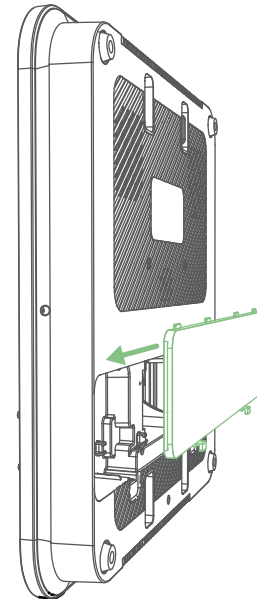

Step 3. Installing Filament Holder

Secure the filament holder with screws.

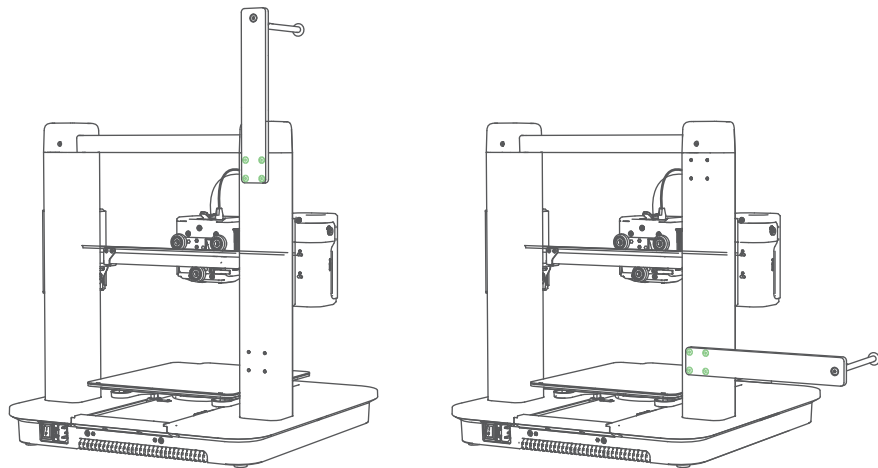

⊙ M4

Option 1

Option 2

Step 4. Connecting to Power

1. Connect the printer to a power outlet with the power cable, then power on the printer.

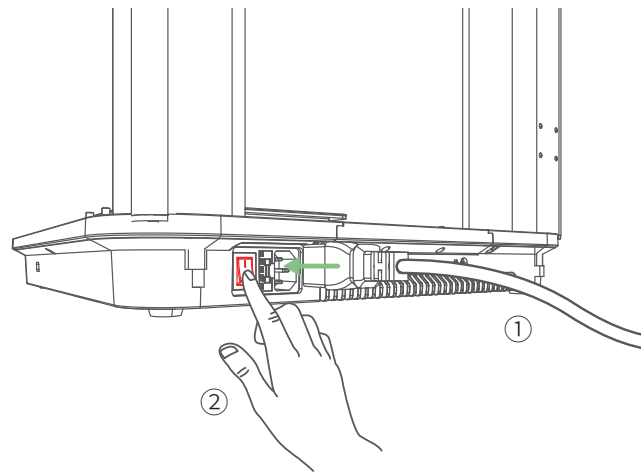

2. Follow instructions on the touch screen to complete the initial setup.

SETTING UP THE SYSTEM

1. Download and install the AnkerMake app, then sign up for an account.



2. Follow on-screen instructions to add the printer to your device list and connect it to Wi-Fi.

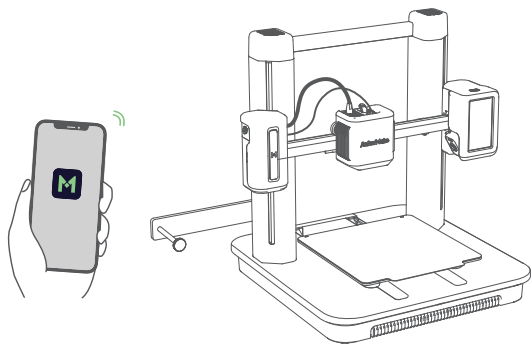

LEVELING HEAT BED

On the touch screen, go to **Control** > **Auto-Level** to level the heat bed.

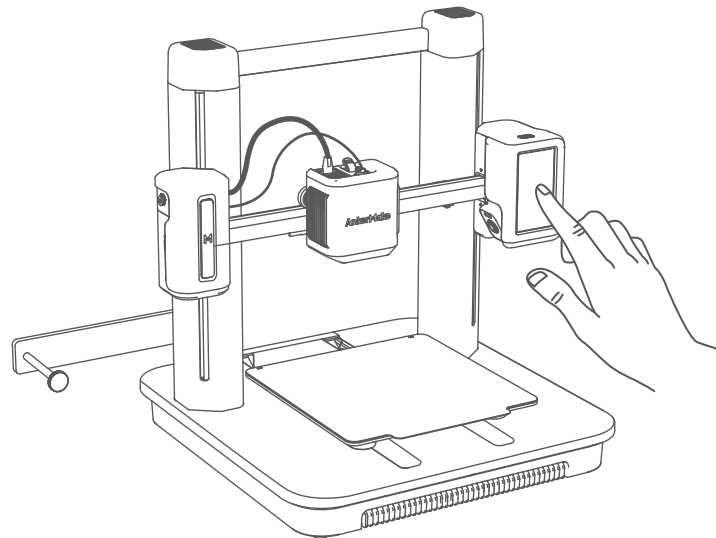

LOADING FILAMENT

1. Place the filament onto the holder.

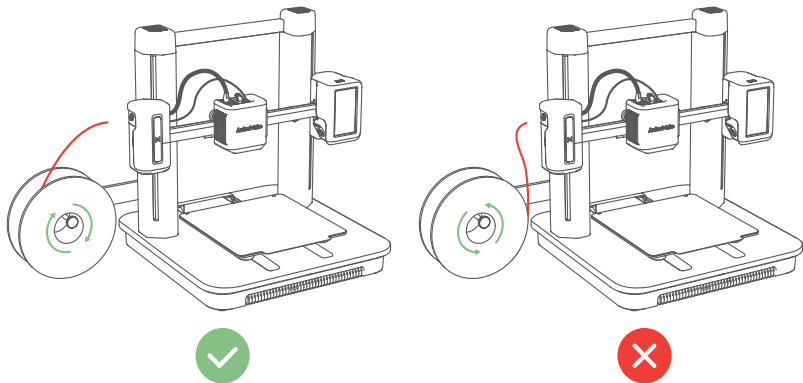

2. Cut the tip of the filament at a 45° angle.

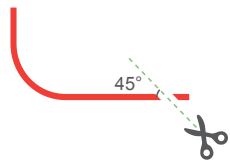

3. Insert the filament until it reaches the extruder. Then press and hold the button on top of the extruder while continuing to insert the filament. Stop when you feel some resistance.

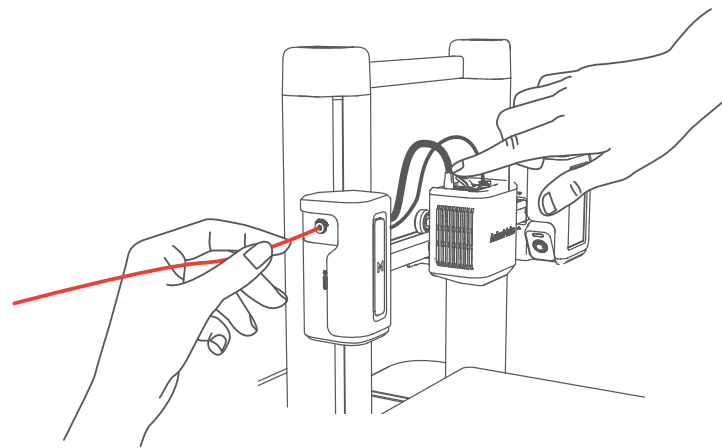

4. On the touch screen, tap **Load** on **Control** > **Extrude**.
Wait until filament flows out of the nozzle, then tap **Stop**.

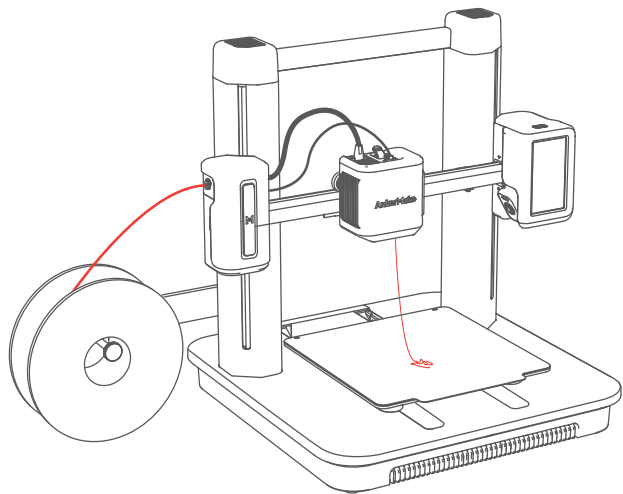

INSTALLING ANKERMAKE SLICER

For the best printing experience, download and install AnkerMake Slicer to your computer from ankermake.com/software.

 The AI recognition capabilities will be not available when the printer works with other 3D slicer software, such as Cura and Simplify3D.

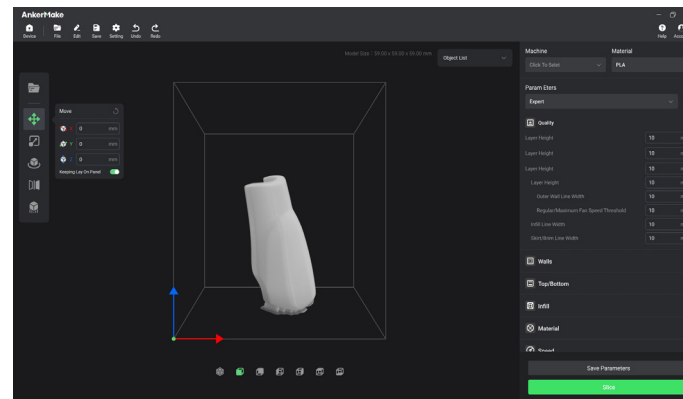

SAFETY

- The power cord shall be connected to socket-outlet with earthing connection.
- The power supply should be installed near the equipment and the socket-outlet must be easily accessible.
- Only use the power cord provided by the manufacturer. Using unauthorized power cords may cause danger and violate the authorization of the product as well as the guarantee.
- Plug of the power cord is considered as the disconnect device. Once unplugged, the product is considered to be disconnected from the power source.
- Do not use the device in an environment where the temperature is too high or too low. Never expose the device to strong sunshine or wet environments.
- The suitable temperature range for the product and its accessories is 15–35°C.
- It is recommended to supply the device in an environment with a temperature that ranges from 15°C ~25°C .
- When supplying, place the device in an environment that has a normal room temperature and good ventilation.
- This equipment is not suitable for use in locations where children are likely to be present. This equipment is not intended for use by children.



Moving parts. Keep body parts away from moving parts.



CAUTION Hot parts. Do not touch.

- Do not use the product in any way other than described herein in order to avoid personal injury or property damage.
- User should comply with the laws and regulations of the corresponding countries and regions where the equipment is located (used), abide by professional ethics, pay attention to safety obligations, and strictly prohibit the use of our products or equipment for any illegal purposes. Our company will not be responsible for any violators' legal liability under any circumstances.

021 EN

NOTICE

Notice (United States Of America)

FCC Statement

This device complies with Part 15 of the FCC Rules. Operation is subject to the following two conditions: (1) this device may not cause harmful interference, and (2) this device must accept any interference received, including interference that may cause undesired operation.

Warning: Changes or modifications not expressly approved by the party responsible for compliance could void the user's authority to operate the equipment.

Note: This equipment has been tested and found to comply with the limits for a Class B digital device, pursuant to Part 15 of the FCC Rules. These limits are designed to provide reasonable protection against harmful interference in a residential installation.

This equipment generates uses and can radiate radio frequency energy and, if not installed and used in accordance with the instructions, may cause harmful interference to radio communications. However, there is no guarantee that interference will not occur in a particular installation. If this equipment does cause harmful interference to radio or television reception, which can be determined by turning the equipment off and on, the user is encouraged to try to correct the interference by one or more of the following measures: (1) Reorient or relocate the receiving antenna. (2) Increase the separation between the equipment and receiver. (3) Connect the equipment into an outlet on a circuit different from that to which the receiver is connected. (4) Consult the dealer or an experienced radio/TV technician for help.

FCC Radio Frequency Exposure Statement

The device has been evaluated to meet general RF exposure requirements. The device can be used in fixed/mobile exposure condition. The min separation distance is 20cm.

Notice: Shielded cables

All connections to other computing devices must be made using shielded cables to maintain compliance with FCC regulations.

EN 022

Notice (Canada)

This device complies with Industry Canada licence-exempt RSS standard(s). Operation is subject to the following two conditions:

- (1) this device may not cause interference, and
- (2) this device must accept any interference, including interference that may cause undesired operation of the device.

Le présent appareil est conforme aux CNR d'Industrie Canada applicables aux appareils radio exempts de licence. L'exploitation est autorisée aux deux conditions suivantes:

- (1) l'appareil ne doit pas produire de brouillage, et
- (2) l'utilisateur de l'appareil doit accepter tout brouillage radioélectrique subi, même si le brouillage est susceptible d'en compromettre le fonctionnement.

This Class B digital apparatus complies with Canadian ICES-003.

Cet appareil numérique de la classe B est conforme à la norme NMB-003 du Canada.

IC RF Statement:

When using the product, maintain a distance of 20cm from the body to ensure compliance with RF exposure requirements.

The following importer is the responsible party

Company Name: Fantasia Trading LLC

Address: 5350 Ontario Mills Pkwy, Suite 100, Ontario, CA 91764

Telephone: 1-800-988-7973

Lors de l'utilisation du produit, maintenez une distance de 20 cm du corps afin de vous conformer aux exigences en matière d'exposition RF.

Notice (Europe and United Kingdom)



This product complies with the radio interference requirements of the European Community.

Declaration of Conformity

Hereby, Anker Innovations Limited declares that this device is in compliance with the essential requirements and other relevant provisions of Directive 2014/53/EU. For the declaration of conformity, visit the Web site: <https://ankermake.com>.



This product complies with the radio interference requirements of the United Kingdom

Declaration of Conformity

Hereby, Anker Innovations Limited declares that this device is in compliance with Radio Equipment Regulations 2017 (SI 2017/1206). The full text of the UK declaration of conformity is available at the following internet address: <https://ankermake.com>.

RF exposure information:

The Maximum Permissible Exposure (MPE) level has been calculated based on a distance of d=20 cm between the device and the human body. To maintain compliance with RF exposure requirement, use product that maintain a 20cm distance between the device and human body.

Frequency bands and power are as below:

Function	Bands	Operation Frequency	Max.Power
Wi-Fi	2.4GHz	2412-2472MHz	EIRP 19.10 dBm
Bluetooth	2.4GHz	2402-2480 MHz	EIRP 8.0 dBm

The following importer is the responsible party (contract for EU matters):
Anker Innovations Deutschland GmbH | Georg-Muche-Strasse 3, 80807 Munich, Germany

The following importer is the responsible party (contract for UK matters):
Anker Technology (UK) Limited | GNR8, 49 Clarendon Road, Watford, Hertfordshire, WD17 1HP, United Kingdom



Your product is designed and manufactured with high quality materials and components, which can be recycled and reused.



This symbol means the product must not be discarded as household waste, and should be delivered to an appropriate collection facility for recycling. Proper disposal and recycling helps protect natural resources, human health and the environment. For more information on disposal and recycling of this product, contact your local municipality, disposal service, or the shop where you bought this product.

Trademarks



The Bluetooth® word mark and logos are registered trademarks owned by the Bluetooth SIG, Inc. and any use of such marks by Anker Innovations Limited is under license. Other trademarks and trade names are those of their respective owners.

025 EN

AUF EINEN BLICK

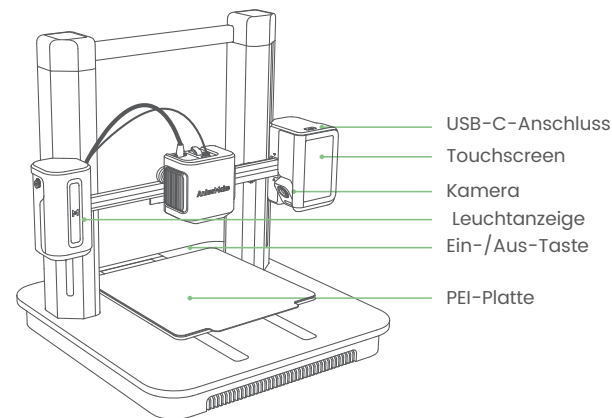

Leuchtanzeige*	Beschreibung
Blinkt langsam orange	Aufheizen
Verblasendes Grün wiederholt	Drucken
Blinkt rot	Ein Alarm wird aktiviert

* Weitere Informationen zum Status der Leuchtanzeige finden Sie unter <https://www.ankermake.com>.

Produktname: AnkerMake M5 Modell: V8111

DE 026

ZUSAMMENBAU DES DRUCKERS

Werkzeug und Bauteile

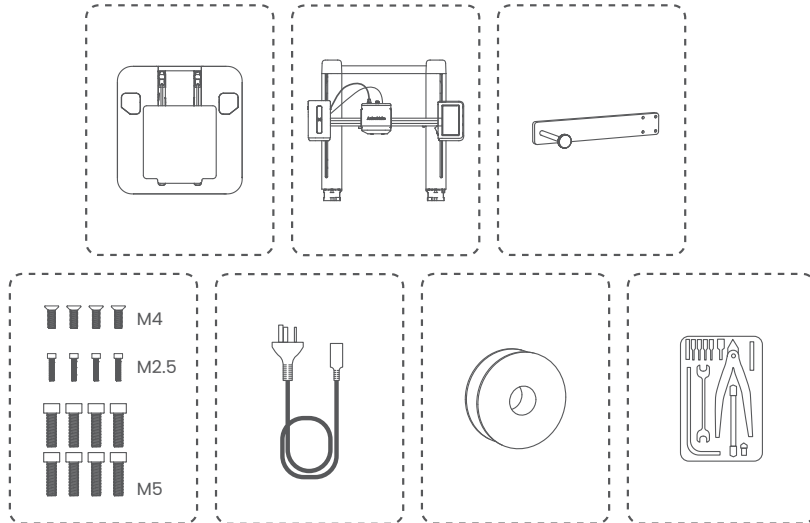

SCHRITT 1. Installieren des Portalrahmens

1. Öffnen Sie den Behälter und legen Sie die Schaumstoffabdeckung auf den Boden.

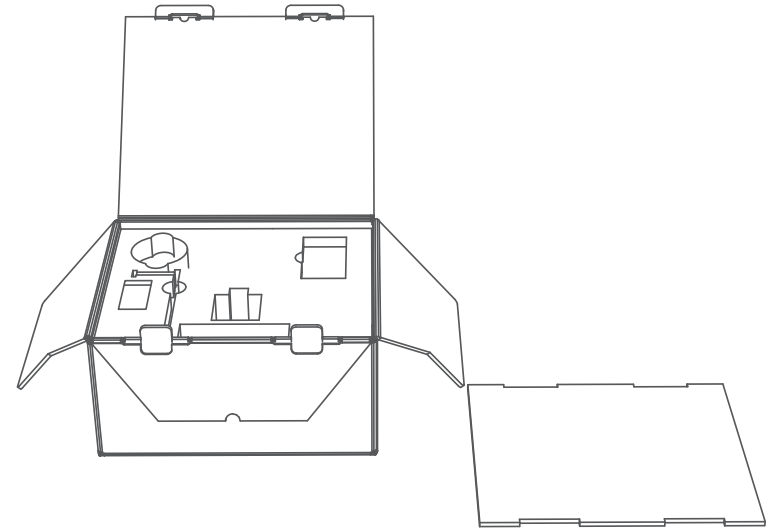

2. Nehmen Sie alle Zubehörteile aus dem Schaumstoff heraus und legen Sie dann den Schutzschaumstoff als Unterlage auf den Boden.

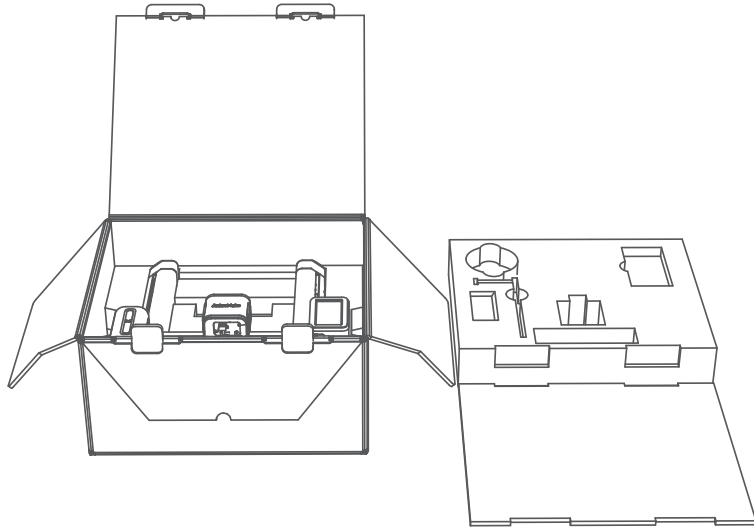

029 DE

3. Nehmen Sie den Portalrahmen mit seinem Schutzschaumstoff heraus und legen Sie ihn auf die Schaumstoffunterlage.

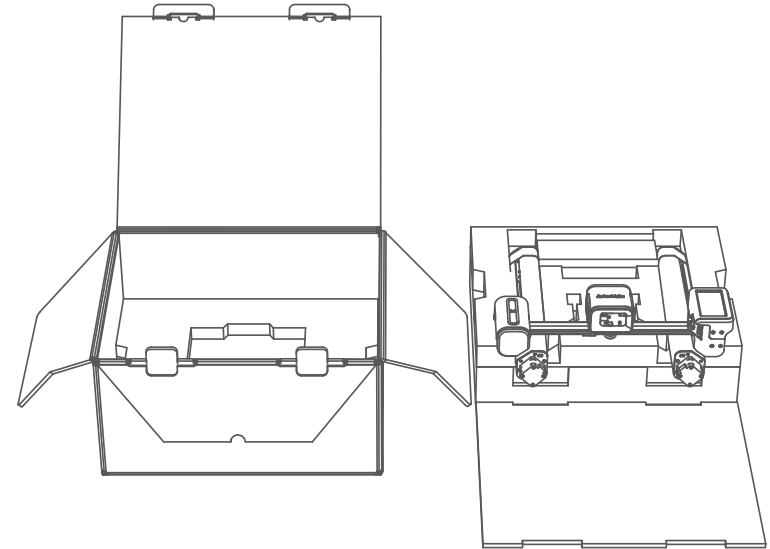

DE 030

4. Nehmen Sie den Portalrahmen aus dem Verpackungsschaumstoff und setzen Sie ihn wie unten gezeigt wieder ein.

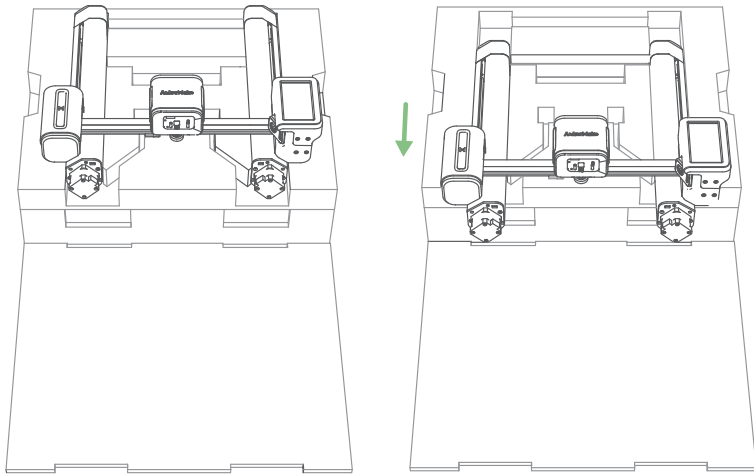

031 DE

5. Nehmen Sie die untere Abdeckung von der Plattform ab.

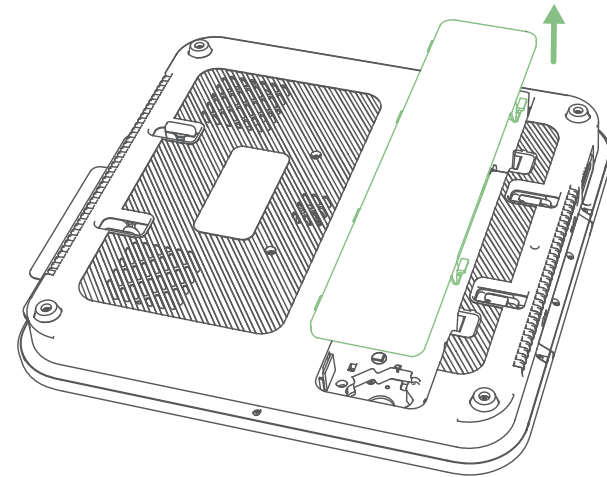

DE 032

6. Montieren Sie die Plattform durch die Löcher.

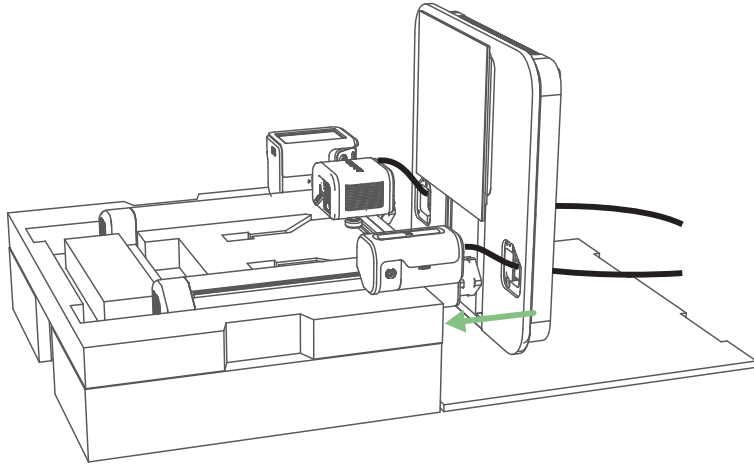

7. Drehen Sie die Schrauben in die Plattform.

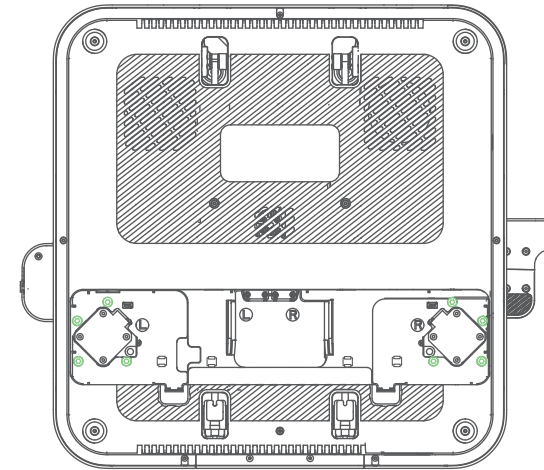

⊙ M5

SCHRITT 2. Verkabelung

1. Schließen Sie die Motorkabel an.

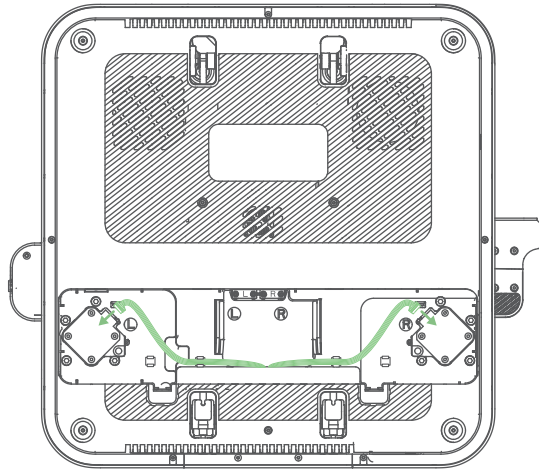

2. Schließen Sie die USB-C-Kabel an und befestigen Sie sie mit Schrauben.

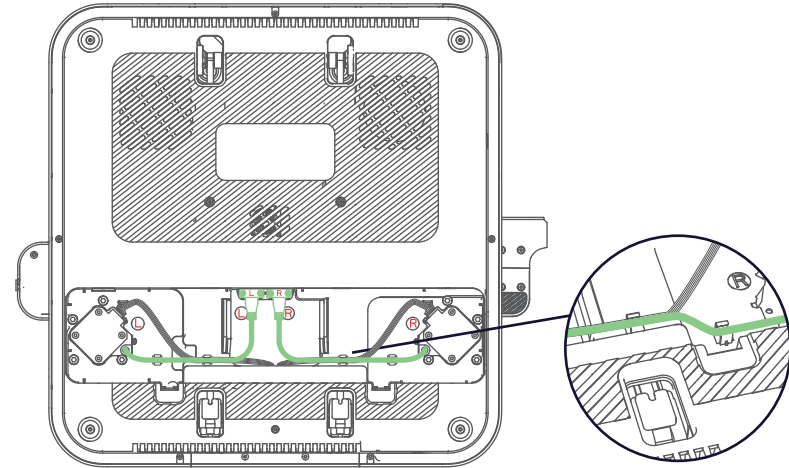

© M2.5

3. Setzen Sie die untere Abdeckung wieder auf die Plattform.

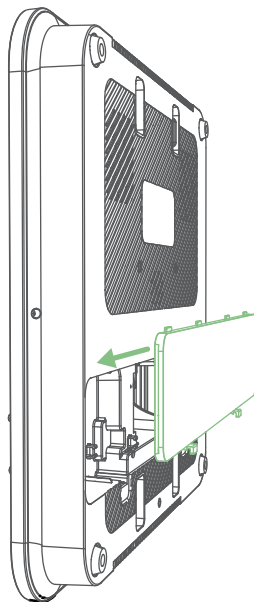

SCHRITT 3. Installieren des Filamenthalters

Befestigen Sie den Filamenthalter mit Schrauben.

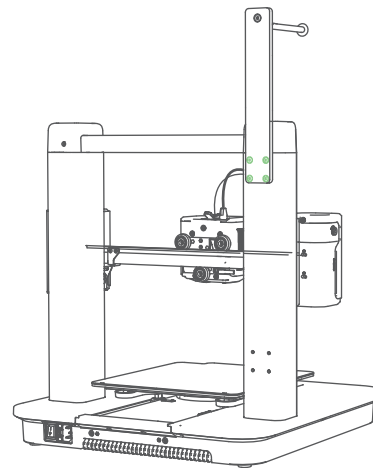

Option 1

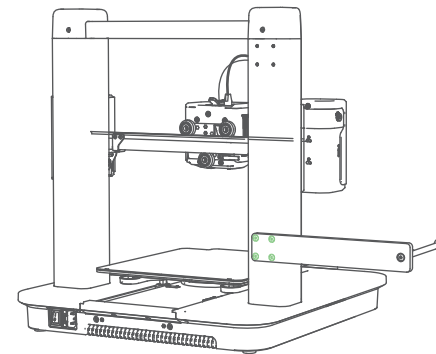

Option 2

⊙ M4

SCHRITT 4. Anschließen an die Stromversorgung

1. Schließen Sie den Drucker mit dem Netzkabel an eine Steckdose an und schalten Sie den Drucker dann ein.

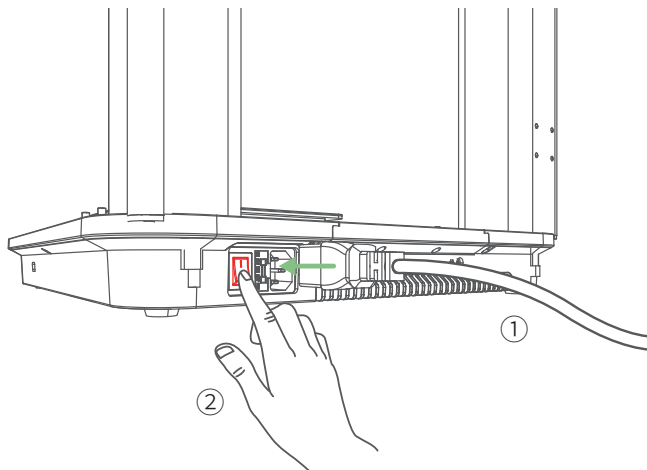

2. Folgen Sie den Anweisungen auf dem Touchscreen, um die Ersteinrichtung abzuschließen.

039 DE

Einrichten des Systems

1. Laden Sie die AnkerMake-App herunter, installieren Sie sie und richten Sie anschließend ein Konto ein.



2. Befolgen Sie die Anweisungen auf dem Bildschirm, um den Drucker zu Ihrer Geräteliste hinzuzufügen und ihn mit dem WLAN zu verbinden.

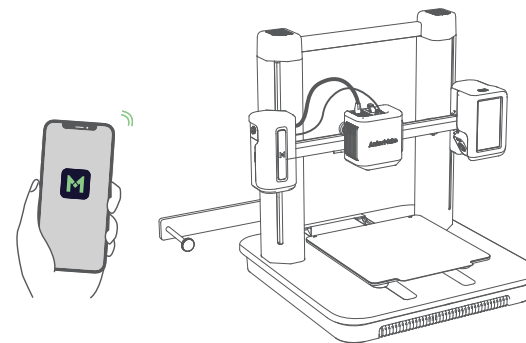

DE 040

NIVELLIERUNG DES HEIZBETTS

Gehen Sie auf dem Touchscreen zu „**Steuerung** > **Automatische Nivellierung**“, um das Heizbett zu nivellieren.

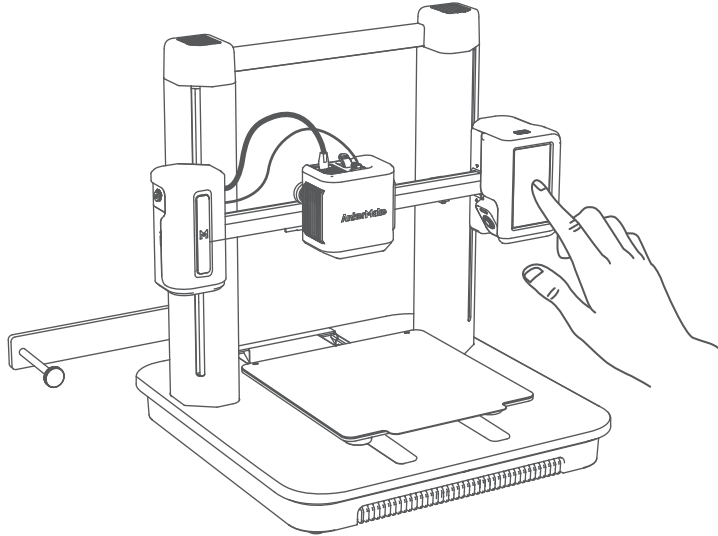

EINLEGEN DES FILAMENTS

1. Legen Sie das Filament auf den Halter.

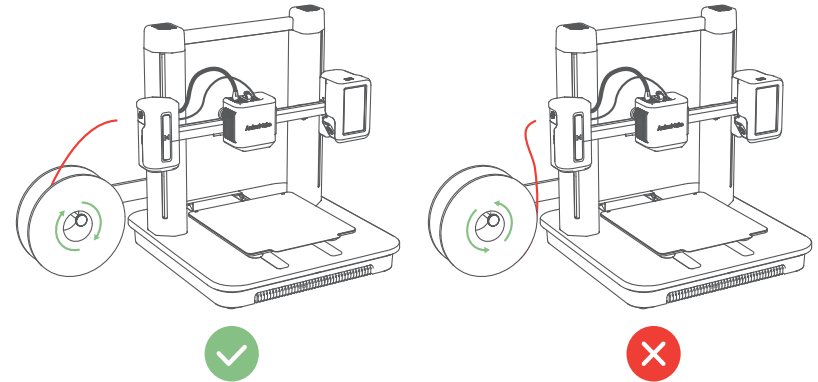

2. Schneiden Sie die Spitze des Filaments in einem 45°-Winkel ab.

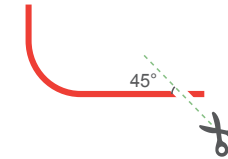

3. Führen Sie das Filament ein, bis es den Extruder erreicht. Halten Sie dann die Taste oben auf dem Extruder gedrückt, während Sie das Filament weiter einführen. Hören Sie auf, wenn Sie einen Widerstand spüren.

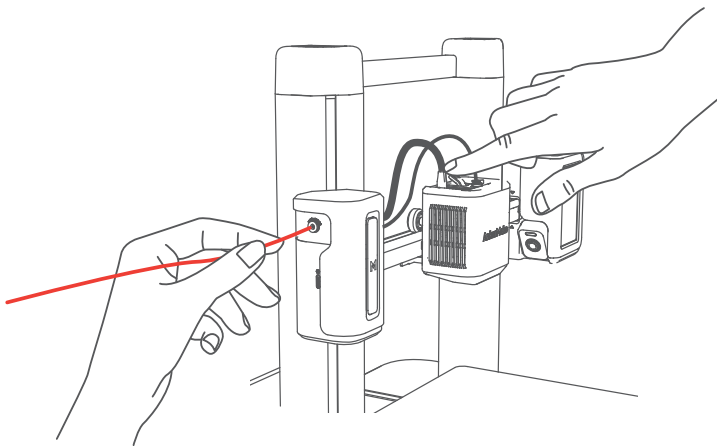

4. Tippen Sie auf dem Touchscreen unter „**Steuerung**“ > „**Laden**“ > „**Extrudieren**“.
Warten Sie, bis das Filament aus der Düse fließt, und tippen Sie dann auf „**Stopp**“.

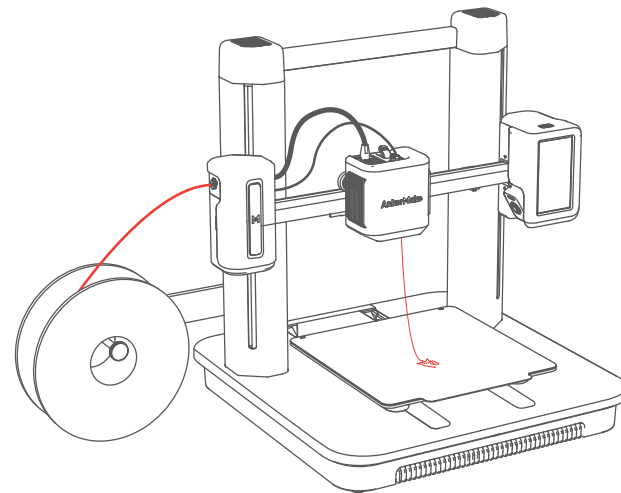



INSTALLIEREN DES ANKERMAKE SLICERS

Laden Sie für ein optimales Druckerlebnis den AnkerMake Slicer von ankermake.com/software herunter und installieren Sie ihn auf Ihrem Computer.

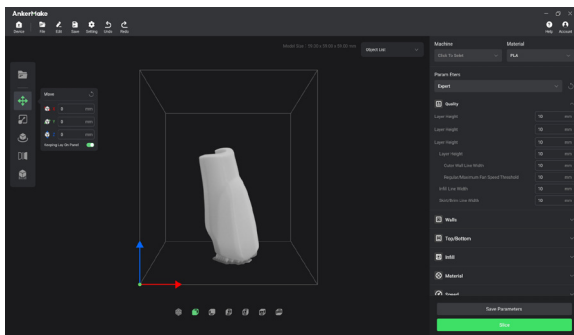
💡 Die KI-Erkennungsfunktionen sind nicht verfügbar, wenn der Drucker mit einer anderen 3D-Slicer-Software wie Cura und Simplify3D arbeitet.



SICHERHEIT

- Das Netzkabel muss an eine geerdete Steckdose angeschlossen werden.
- Die Stromversorgung sollte in der Nähe des Geräts installiert werden und die Steckdose muss leicht zugänglich sein.
- Verwenden Sie ausschließlich das vom Hersteller mitgelieferte Netzkabel. Die Verwendung von nicht zugelassenen Netzkabeln kann eine Gefahr darstellen und die Zulassung des Produkts sowie die Garantiebedingungen verletzen.
- Der Stecker des Netzkabels ist die Trennvorrichtung des Geräts. Einmal ausgesteckt, gilt das Produkt als von der Stromquelle getrennt.
- Verwenden Sie das Gerät nicht in einer Umgebung, in der die Temperatur zu hoch oder zu niedrig ist. Setzen Sie das Gerät niemals zu starker Sonneneinstrahlung oder einer zu feuchten Umgebung aus.
- Der geeignete Temperaturbereich für das Produkt und das Zubehör ist 15 °C bis 35 °C.
- Es wird empfohlen, das Gerät in einer Umgebung mit einer Temperatur im Bereich von 15 °C bis 25 °C bereitzustellen.
- Stellen Sie das Gerät während der Bereitstellung in einer Umgebung mit normaler Raumtemperatur und angemessener Belüftung auf.
- Dieses Gerät ist nicht für den Einsatz an Orten geeignet, an denen sich Kinder aufhalten können. Dieses Gerät ist nicht für den Gebrauch durch Kinder bestimmt.
-  Bewegliche Teile. Halten Sie Körperteile von beweglichen Teilen fern.
-  VORSICHT Heiße Teile. Nicht berühren.
- Verwenden Sie das Produkt nicht anders als hier beschrieben, um Personen- oder Sachschäden zu vermeiden.
- Der Benutzer sollte die Gesetze und Vorschriften der entsprechenden Länder und Regionen, in denen das Gerät aufgestellt (verwendet) wird, einhalten, sich an die Berufsethik halten, auf die Sicherheitsverpflichtungen achten und die Verwendung unserer Produkte oder Geräte für illegale Zwecke strikt untersagen. Unser Unternehmen ist unter keinen Umständen für die gesetzliche Haftung von Verstößen verantwortlich.

HINWEIS

Hinweis (Europa und Vereinigtes Königreich)



Dieses Produkt erfüllt die Anforderungen der Europäischen Gemeinschaft an Funkstörungen.

Konformitätserklärung

Anker Innovations Limited erklärt hiermit, dass dieses Gerät die grundlegenden Anforderungen und anderen relevanten Bestimmungen der Richtlinie 2014/53/EG erfüllt. Die Konformitätserklärung finden Sie auf der Website: <https://ankermake.com>.



Dieses Produkt erfüllt die Anforderungen an Funkstörungen des Vereinigten Königreichs

Konformitätserklärung

Anker Innovations Limited erklärt hiermit, dass dieses Gerät die Funkanlagenrichtlinie 2017 (SI 2017/1206) erfüllt. Der vollständige Text der britischen Konformitätserklärung ist unter der folgenden Internetadresse verfügbar: <https://ankermake.com>.

Informationen zur HF-Exposition:

Die maximal zulässige Exposition (MPE) wurde basierend auf einem Abstand von $d = 20$ cm zwischen dem Gerät und dem menschlichen Körper berechnet. Um die Anforderungen in Bezug auf die HF-Belastung zu erfüllen, muss zwischen dem Gerät und dem menschlichen Körper ein Abstand von mindestens 20 cm bestehen.

Die Frequenzbänder und Leistung sind wie folgt:

Funktion	Bänder	Betriebsfrequenz	Maximale Leistung
WLAN	2,4 GHz	2412–2472 MHz	EIRP 19,10 dBm
Bluetooth	2,4 GHz	2.402 – 2.480 MHz	EIRP 8,0 dBm

Der folgende Importeur ist verantwortlich (Vertrag für EU-Belange):

Anker Innovations Deutschland GmbH | Georg-Muche-Straße 3, 80807 München, Deutschland

Der folgende Importeur ist verantwortlich (Vertrag für UK-Belange):

Anker Technology (UK) Limited | GNR8, 49 Clarendon Road, Watford, Hertfordshire, WD17 1HP, United Kingdom



Ihr Produkt wird mit hochwertigen Materialien und Komponenten gefertigt, die recycelt und wiederverwendet werden können.



Dieses Symbol bedeutet, dass das Produkt nicht als Hausmüll entsorgt werden darf, sondern einer angemessenen Sammelstelle für das Recycling zugeführt werden muss. Durch das ordnungsgemäße Entsorgen und Recyceln tragen Sie zum Schutz natürlicher Ressourcen und zur Vermeidung von Umwelt- und Gesundheitsschäden bei. Weitere Informationen zu Entsorgung und Recycling des Produkts erhalten Sie von der Gemeinde vor Ort, dem Entsorgungsdienst oder dem Geschäft, in dem Sie dieses Produkt gekauft haben.

VISTA GENERAL

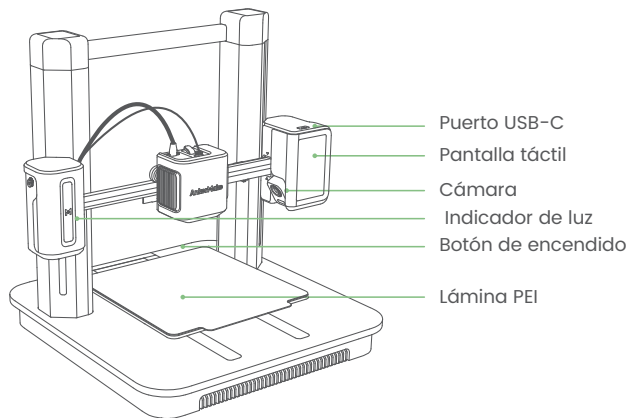

Indicador luminoso*	Descripción
Parpadeo lento en naranja	Calentando
Difuminado repetidas veces en verde	Imprimiendo
Rojo intermitente	Una alarma se ha disparado

* Para más estados de indicadores luminosos, visite <https://www.ankermake.com>.
Nombre del producto: AnkerMake M5 Modelo: V8111

MONTAJE DE LA IMPRESORA

Qué necesita

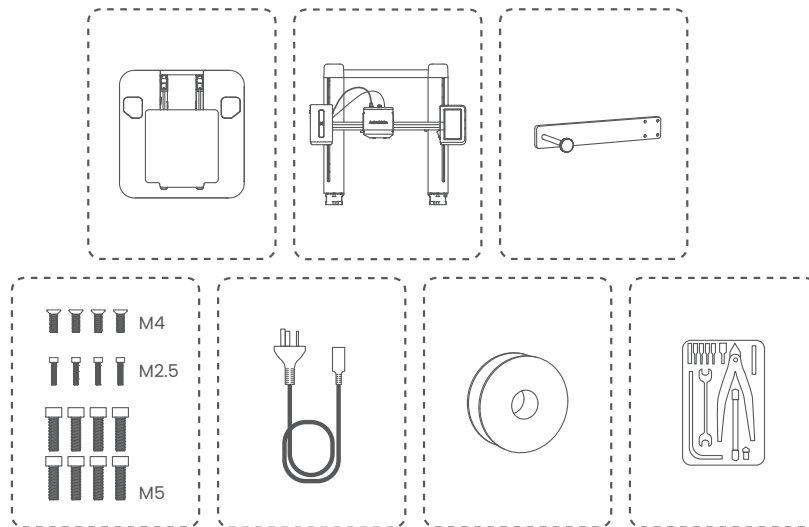

PASO 1. Instalación del pórtico

1. Abra la caja, coloque la cubierta de espuma en el suelo.

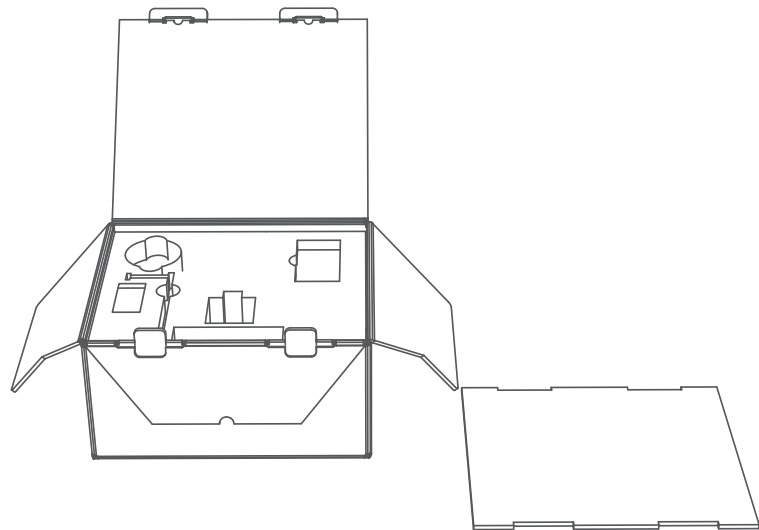

2. Saque todos los accesorios de la espuma, coloque la espuma de protección en el suelo a modo de apoyo.

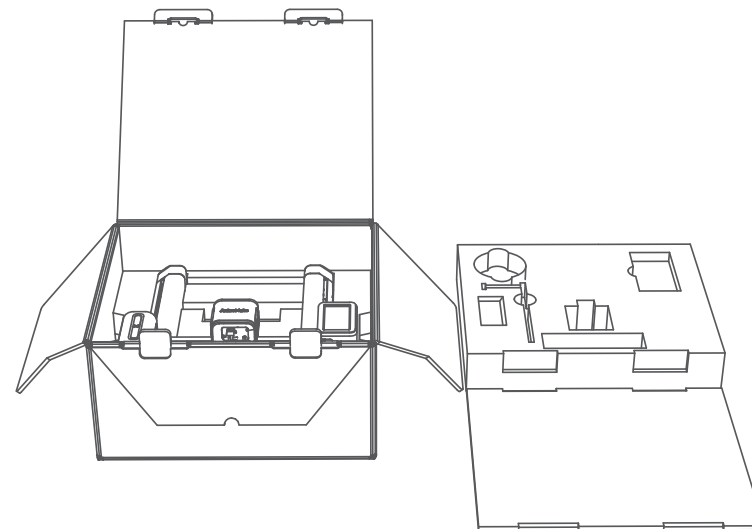

3. Saque el pórtico con su espuma de protección y colóquelo sobre la espuma de apoyo.

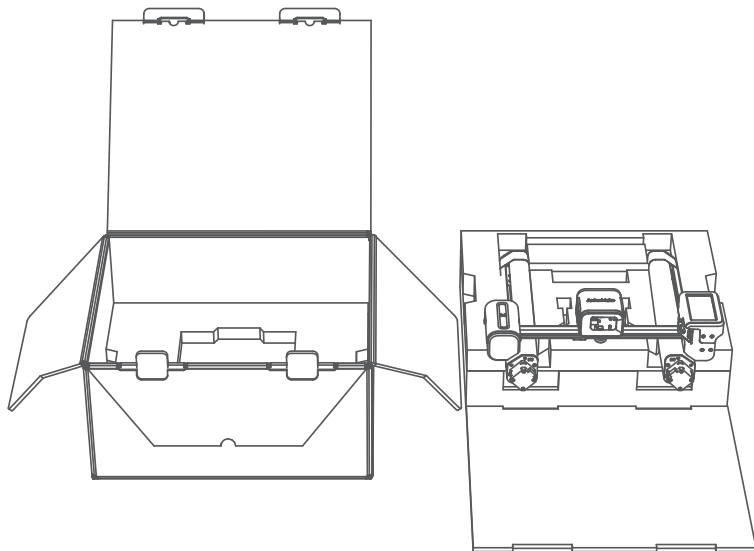

053 ES

4. Saque el pórtico de la espuma de embalaje y luego vuelva a ponerla como se muestra a continuación.

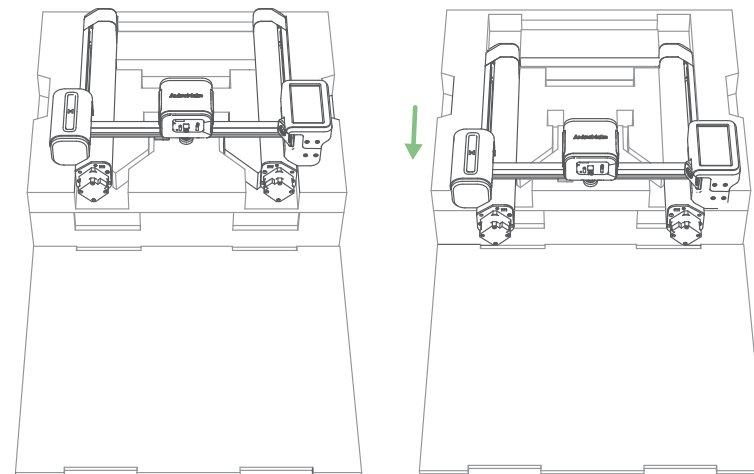

ES 054

5. Quite la tapa inferior de la plataforma.

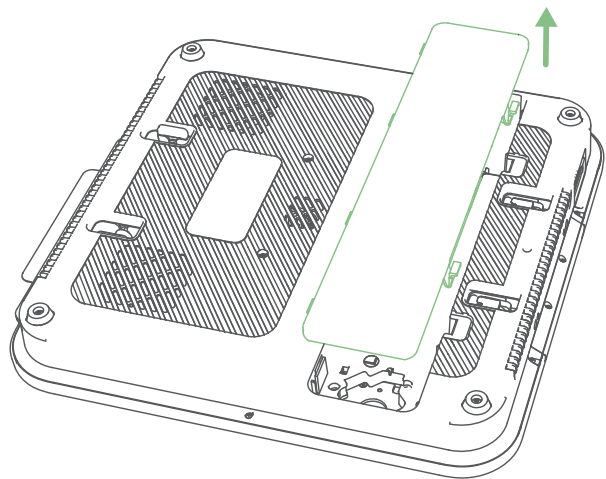

6. Monte la plataforma en los agujeros.

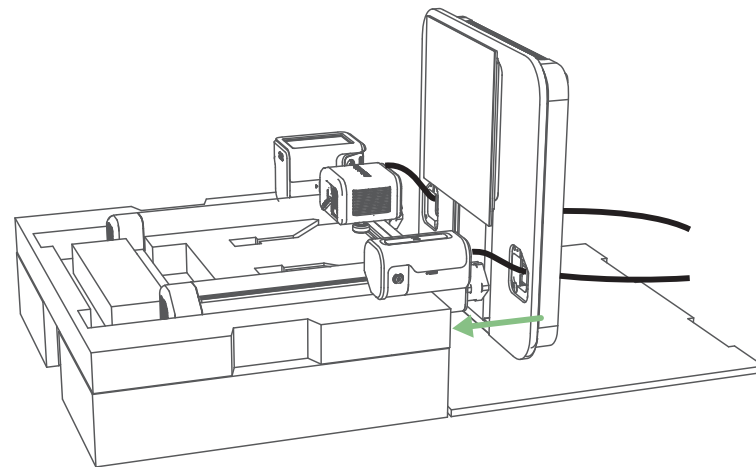

7. Apriete los tornillos en la plataforma.

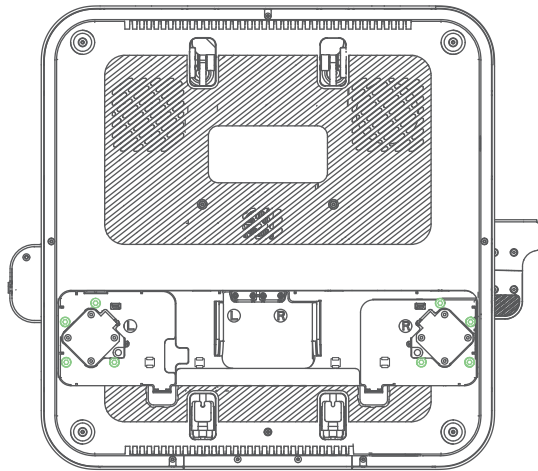

⊙ M5

PASO 2. Cableado

1. Conecte los cables del motor.

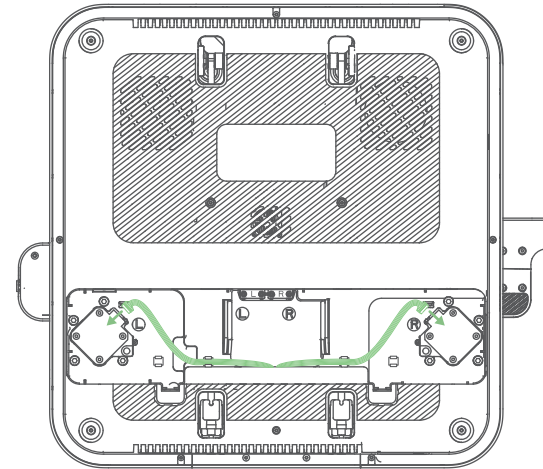

2. Conecte y fije los cables USB-C con tornillos.

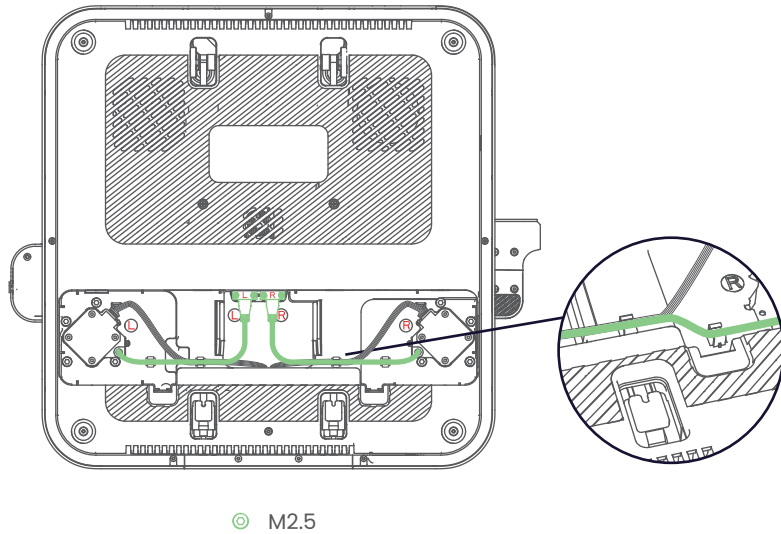

3. Vuelva a poner la tapa inferior en la plataforma.

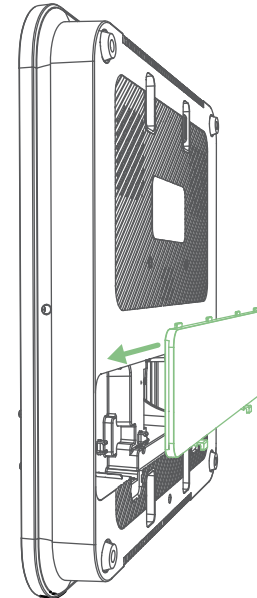

PASO 3. Instalación del soporte de filamentos

Atornille el soporte de filamentos.

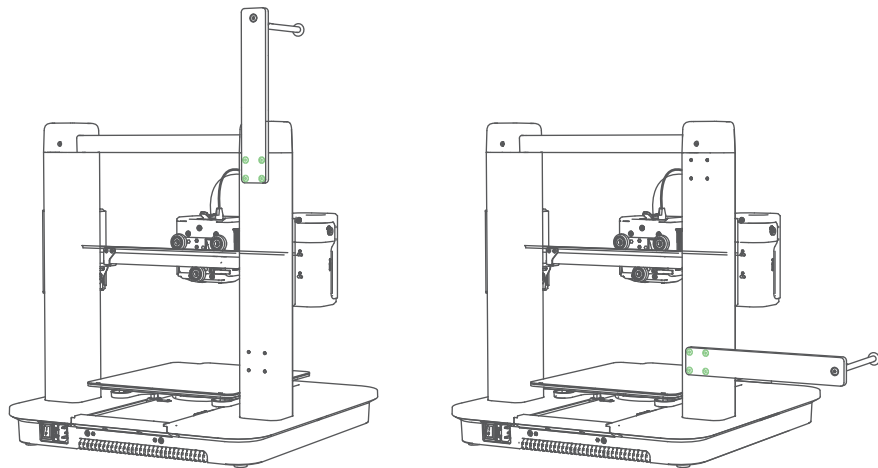

⊙ M4

Opción 1

Opción 2

PASO 4. Conexión a una fuente de alimentación

1. Conecte la impresora a una toma de corriente con el cable de alimentación y, a continuación, encienda la impresora.

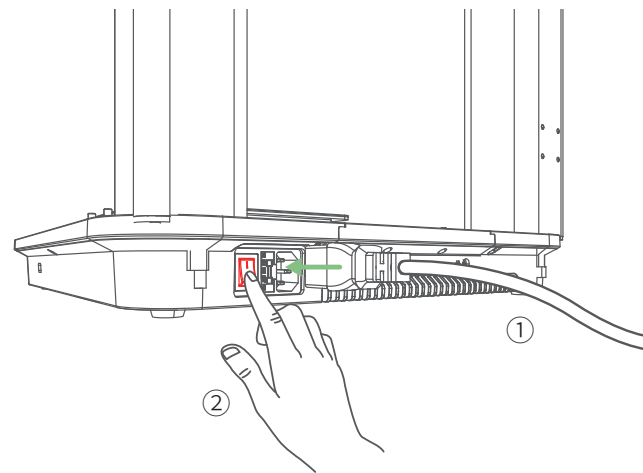

2. Siga las instrucciones en la pantalla táctil para completar la configuración inicial.

Configuración del sistema

1. Descargue e instale la aplicación AnkerMake y regístrese para crear una cuenta.



2. Siga las instrucciones en pantalla para añadir la impresora a la lista de dispositivos y conéctela a la Wi-Fi.

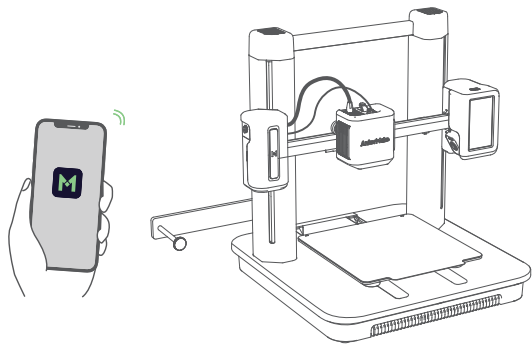

NIVELACIÓN DE LA CAMA DE CALOR

En la pantalla táctil, vaya a **Control** > **Nivelación automática** para nivelar la cama de calor.

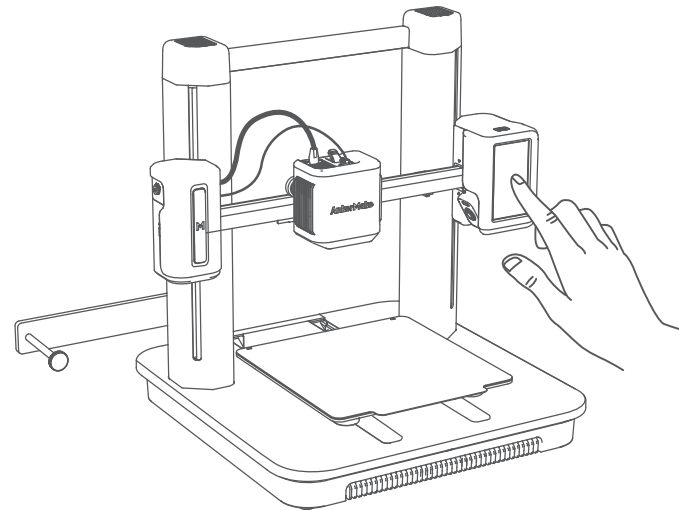

CARGA DEL FILAMENTO

1. Coloque el filamento en el soporte.

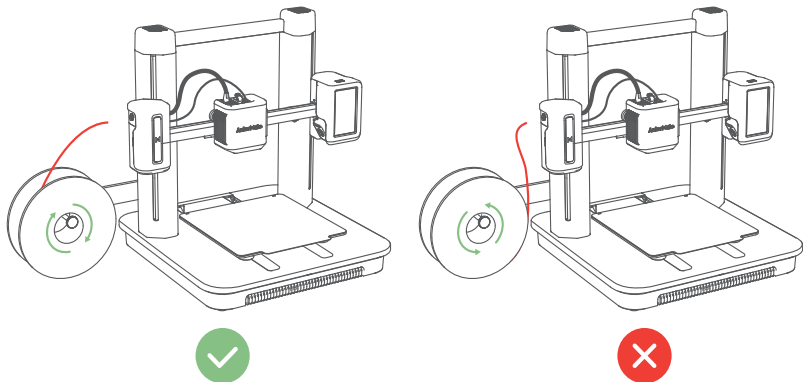

2. Corte la punta del filamento en un ángulo de 45°.

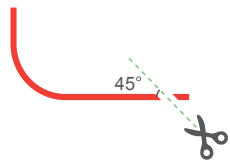

3. Introduzca el filamento hasta que alcance el extrusor. A continuación, mantenga pulsado el botón de la parte superior del extrusor mientras sigue introduciendo el filamento. Deténgase cuando perciba algo de resistencia.

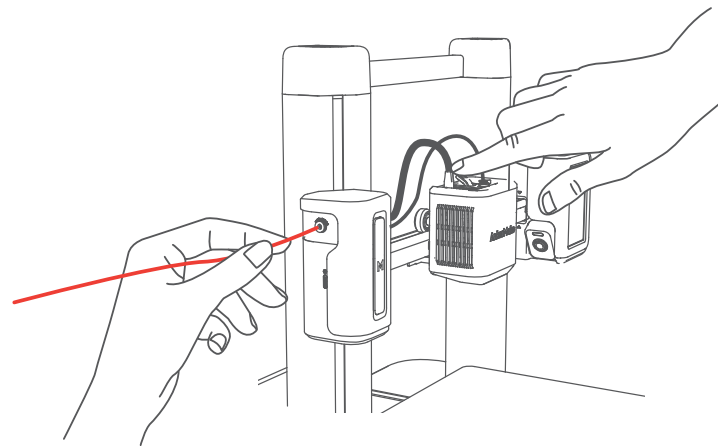

4. En la pantalla táctil, pulse **Carga** en **Control** > **Extruir**. Espere hasta que el filamento rebose por la boquilla y, después, pulse **Stop**.

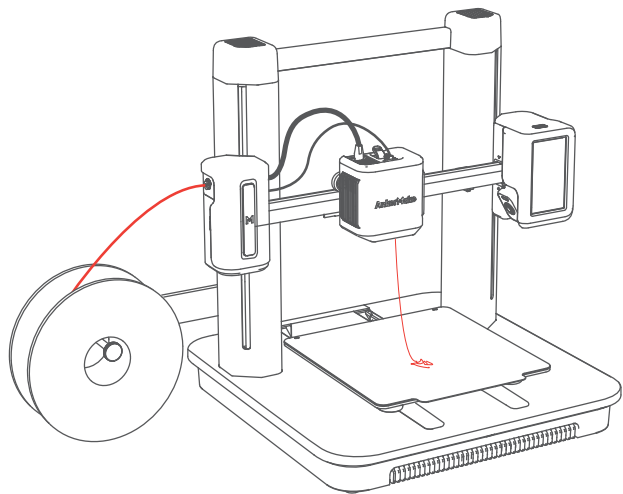



INSTALACIÓN DEL LAMINADOR ANKERMAKE

Para lograr la mejor experiencia de impresión, descargue e instale el laminador AnkerMake a su ordenador desde ankermake.com/software.

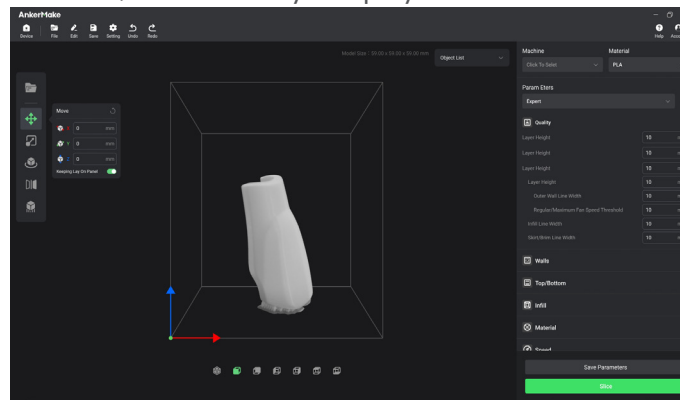
💡 Las capacidades de reconocimiento de la IA no estarán disponibles si la impresora funciona con otro software de laminador 3D, como Cura y Simplify3D.



SEGURIDAD

- El cable de corriente estará conectado a una toma de corriente con conexión a tierra.
- La fuente de alimentación debe estar ubicada cerca del dispositivo y la toma de corriente debe estar en un sitio accesible.
- Use únicamente el cable de corriente del fabricante incluido. Si utiliza cables de corriente no homologados, podría ser causa de peligro e incumplir el uso autorizado del producto y la garantía.
- El conector del cable de corriente se considera el elemento de desconexión. Al desenchufarlo, el producto se considerará desconectado de la fuente de alimentación.
- No utilice el dispositivo en entornos con temperaturas demasiado altas o bajas. No exponga el dispositivo a la luz solar intensa o ambientes húmedos.
- El rango de temperaturas adecuado para el producto y sus accesorios es de 15 a 35 °C.
- Se recomienda tener enchufado el dispositivo en una zona con una temperatura de entre 15 °C y 25 °C.
- Cuando lo tenga enchufado, colóquelo en una zona con una temperatura ambiente normal y una ventilación adecuada.
- El equipamiento no es apto para usarse en lugares frecuentados por niños. Este equipamiento no está diseñado para que lo usen niños.
-  Piezas móviles. Mantenga las piezas fijas separadas de las piezas móviles.
-  PRECAUCIÓN Piezas calientes. No tocar.
- No use el producto de ningún modo diferente a lo descrito en este documento para evitar lesiones personales y daños materiales.
- El usuario debe cumplir la ley y la normativa del país y región donde esté ubicado (se use) el equipamiento, manejarse conforme a la ética profesional, prestar atención a las obligaciones de seguridad y prohibir terminantemente el uso de nuestros productos o equipamientos con fines ilegales. Nuestra empresa no se hace responsable legal de ningún incumplimiento bajo ninguna circunstancia.

069 ES

AVISO

Aviso (Europa y Reino Unido)

 Este producto cumple con los requisitos de radiointerferencias de la Comunidad Europea.

Declaración de conformidad

Por la presente, Anker Innovations Limited declara que este dispositivo cumple los requisitos esenciales y otras disposiciones pertinentes de la Directiva 2014/53/UE. Para consultar la declaración de conformidad, visite el sitio web: <https://ankermake.com>.



Este producto cumple con la normativa sobre radiointerferencias del Reino Unido

Declaración de conformidad

Por la presente, Anker Innovations Limited declara que este dispositivo cumple con lo estipulado en el Reglamento 2017 en materia de equipos radioeléctricos (SI 2017/1206). El texto completo de la declaración de conformidad del Reino Unido está disponible en la siguiente dirección de Internet: <https://ankermake.com>.

ES 070

Información de exposición a RF:

El nivel máximo de exposición permisible (MEP) se ha calculado en función de una distancia de $d = 20$ cm entre el dispositivo y el cuerpo humano. Para preservar el cumplimiento con el requisito de exposición a RF, utilice el producto manteniendo una distancia de 20 cm entre el dispositivo y el cuerpo humano.

Las bandas de frecuencia y de potencia son las siguientes:

Función	Bandas	Frecuencia de funcionamiento	Máxima potencia
Wi-Fi	2,4 GHz	2412-2472 MHz	EIRP 19,10 dBm
Bluetooth	2,4 GHz	2402-2480 MHz	EIRP 8,0 dBm

La siguiente empresa importadora es la parte responsable (contacto en la UE):
Anker Innovations Deutschland GmbH | Georg-Mueller-Strasse 3, 80807 Múnich, Alemania

La siguiente empresa importadora es la parte responsable (contacto en Reino Unido):
Anker Technology (UK) Limited | GNR8, 49 Clarendon Road, Watford, Hertfordshire, WD17 1HP, United Kingdom



Su producto ha sido diseñado y está fabricado con materiales y componentes de alta calidad, que se pueden reciclar y volver a utilizar.



Este símbolo indica que el producto no debe desecharse como residuo doméstico, sino que debe depositarse en unas instalaciones de recogida adecuadas para su reciclaje. La eliminación y el reciclaje adecuados ayudan a proteger los recursos naturales, la salud humana y el medio ambiente. Para obtener más información acerca de la eliminación y el reciclaje de este producto, póngase en contacto con su ayuntamiento, el servicio de retirada de desechos o la tienda donde compró el producto.

RÉCAPITULATIF

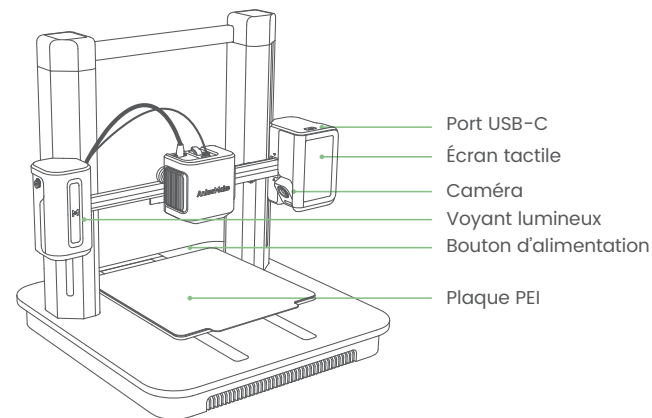

Voyant lumineux*	Description
Orange clignotant lentement	Chauffage en cours
Le vert s'estompe à plusieurs reprises	Impression
Rouge clignotant	Une alarme se déclenche

* Pour plus d'informations sur l'état des voyants, visitez <https://www.ankermake.com>.
Nom du produit : Modèle AnkerMake M5 : V8111

ASSEMBLAGE DE L'IMPRIMANTE

Éléments requis

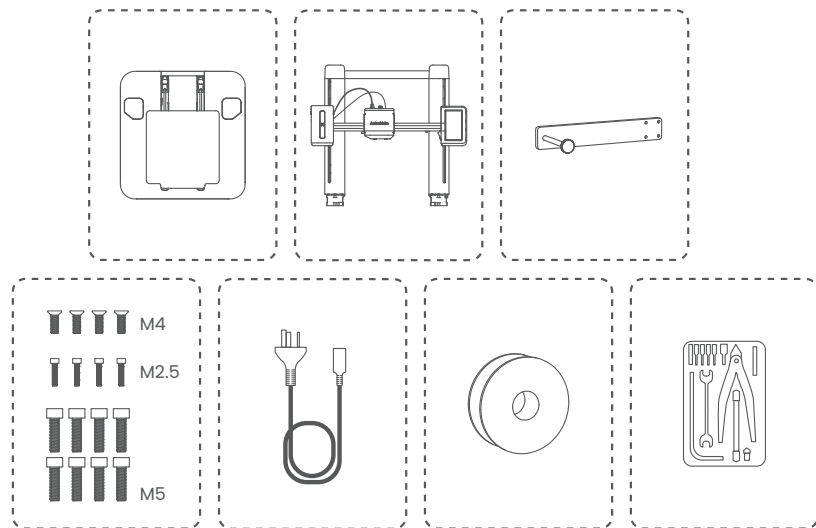

ÉTAPE 1. Installation du cadre du portique

1. Ouvrez la boîte, puis placez le couvercle en mousse sur le sol.

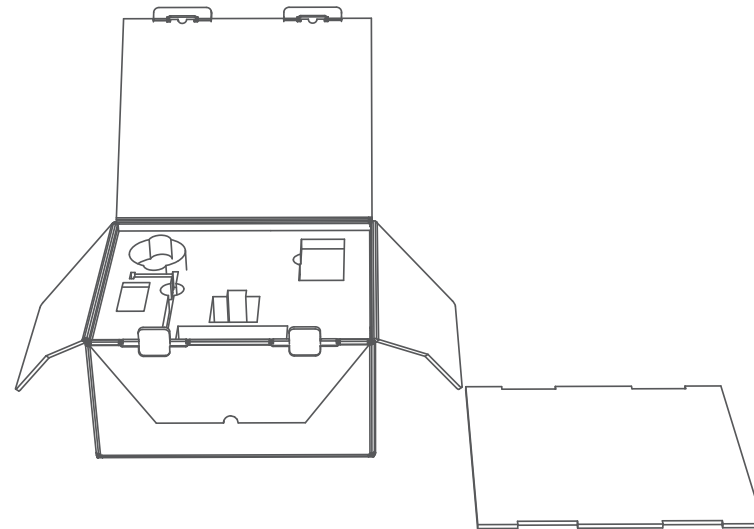

2. Sortez tous les accessoires de la mousse, puis placez la mousse de protection sur le sol comme support.

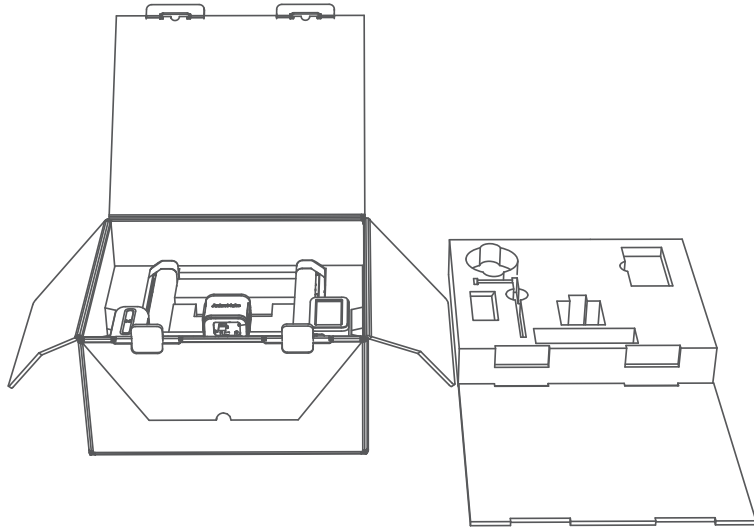

075 FR

3. Sortez le châssis du portique avec sa mousse de protection et posez-le sur la mousse de support.

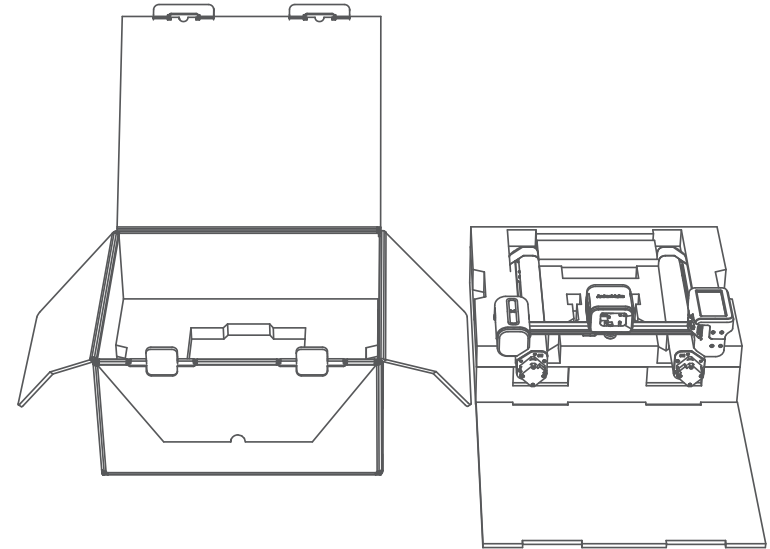

FR 076

4. Sortez le cadre du portique de la mousse d'emballage, puis remettez-le en place comme indiqué ci-dessous.

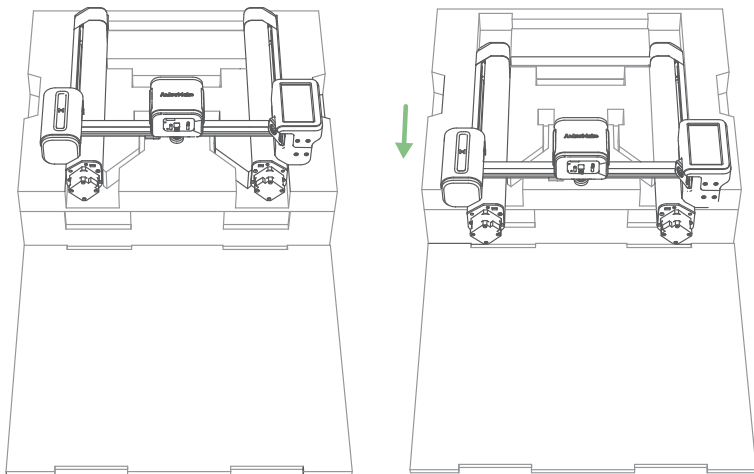

077 FR

5. Détachez le capot inférieur de la plate-forme.

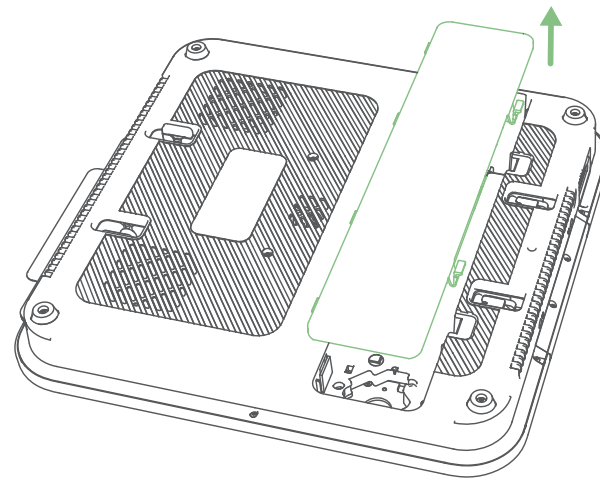

FR 078

6. Montez la plate-forme à travers les trous.

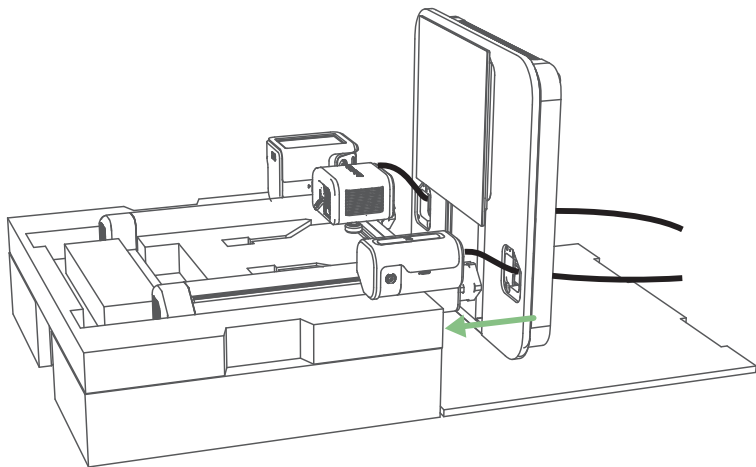

7. Fixez les vis dans la plate-forme.

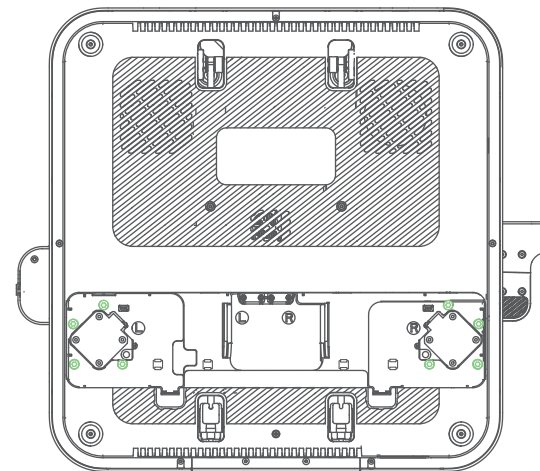

⊙ M5

ÉTAPE 2. Câblage

1. Connectez les fils du moteur.

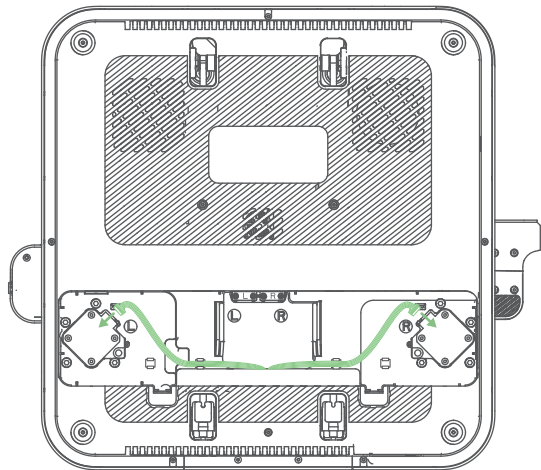

2. Connectez et fixez les câbles USB-C avec des vis.

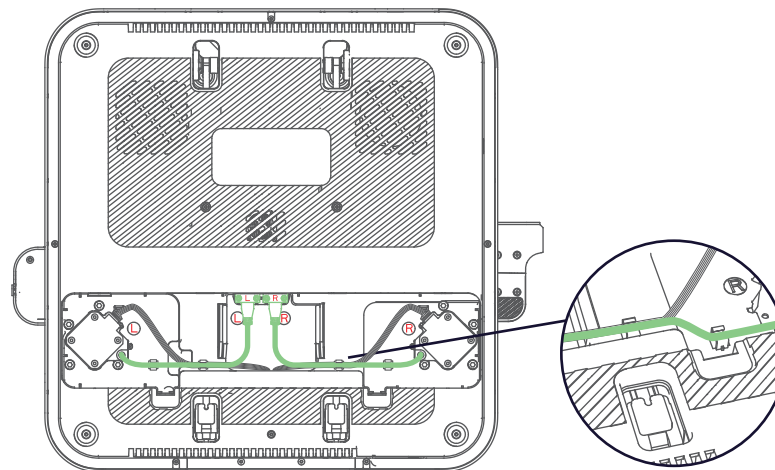

⊙ M2.5

3. Remettez le capot inférieur sur la plate-forme.

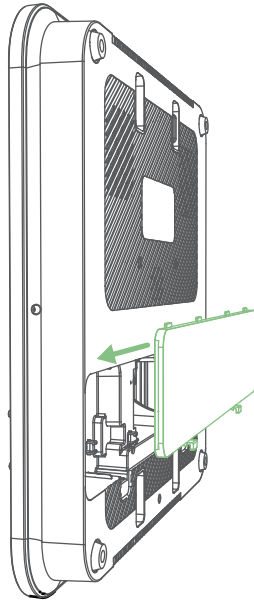

ÉTAPE 3. Installation du support de filament

Fixez le support de filament avec des vis.

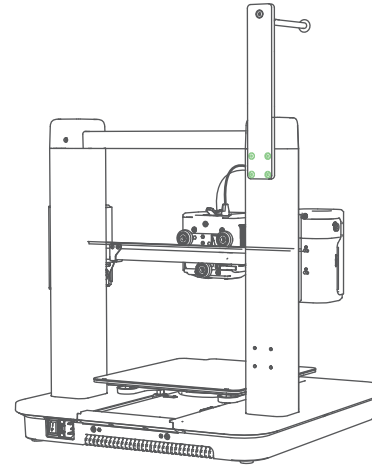

Option 1

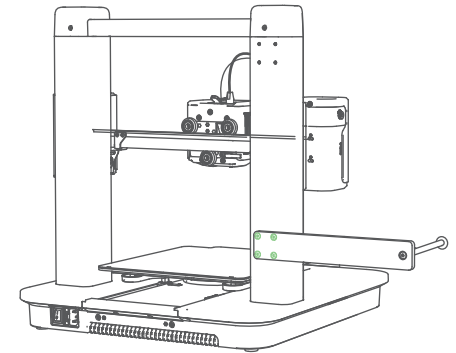

Option 2

⊙ M4

ÉTAPE 4. Connexion à l'alimentation

1. Raccordez l'imprimante à une prise d'alimentation à l'aide du câble d'alimentation, puis mettez l'imprimante sous tension.

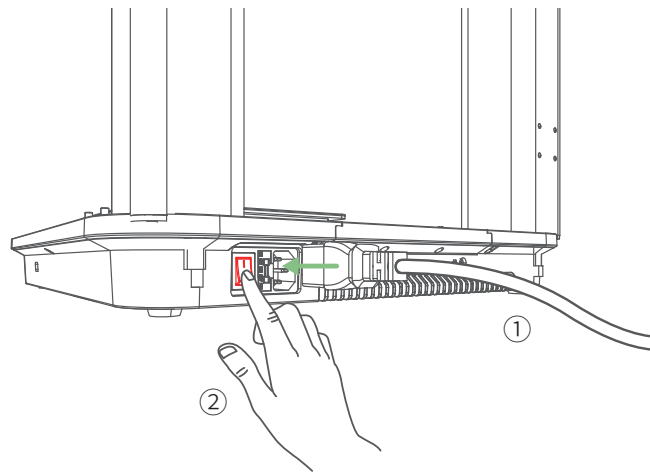

2. Suivez les instructions sur l'écran tactile pour terminer l'installation initiale.

Configuration du système

1. Téléchargez et installez l'application AnkerMake, puis inscrivez-vous pour obtenir un compte.



2. Suivez les instructions à l'écran pour ajouter l'imprimante à votre liste d'appareils et la connecter au Wi-Fi.

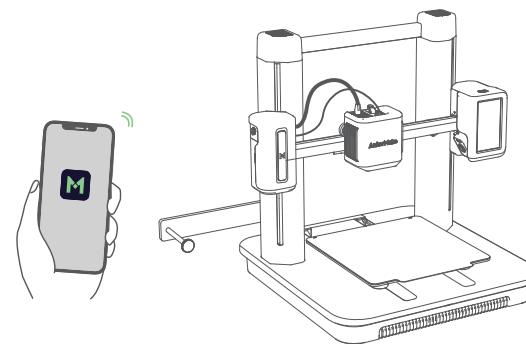

MISE À NIVEAU DU LIT CHAUFFANT

Sur l'écran tactile, accédez à **Control** > **Auto-Level** pour mettre à niveau le lit chauffant.

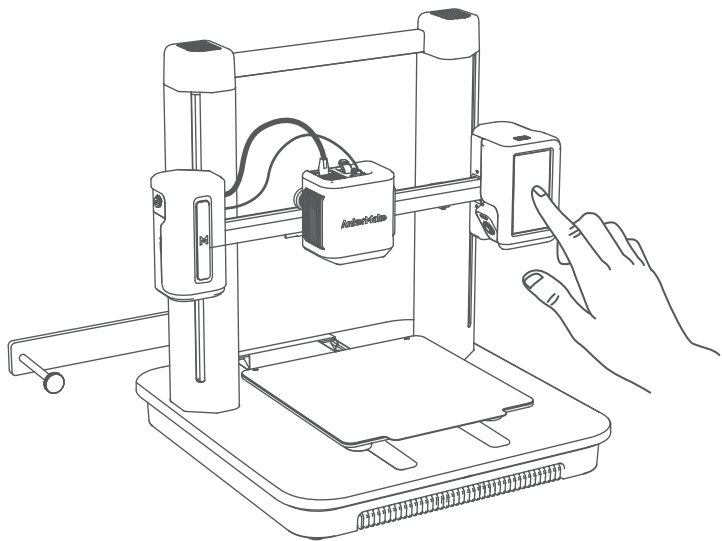

087 FR

CHARGEMENT DU FILAMENT

1. Placez le filament sur le support.

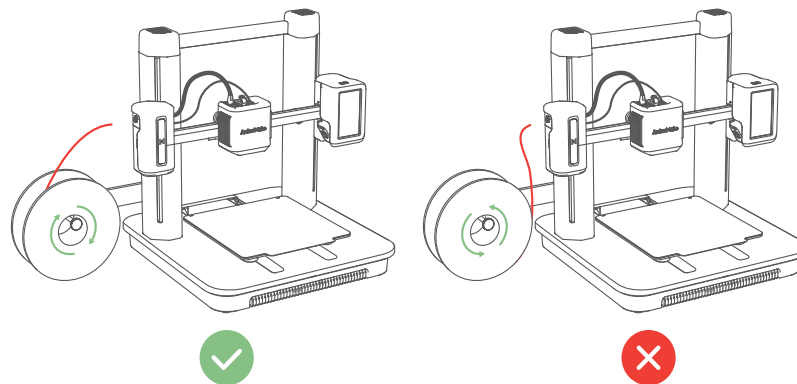

2. Coupez la pointe du filament à un angle de 45°.

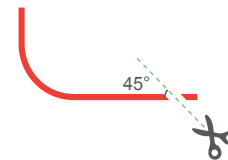

FR 088

3. Insérez le filament jusqu'à ce qu'il atteigne l'extrudeur. Appuyez ensuite sur le bouton situé sur le dessus de l'extrudeur et maintenez-le enfoncé tout en continuant à insérer le filament. Arrêtez-vous lorsque vous sentez une certaine résistance.

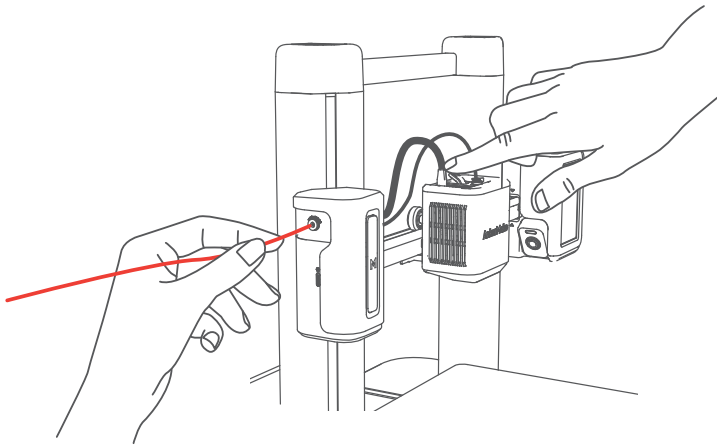

4. Sur l'écran tactile, appuyez sur **Load on Control > Extrude**. Attendez que le filament sorte de la buse, puis appuyez sur **Stop**.

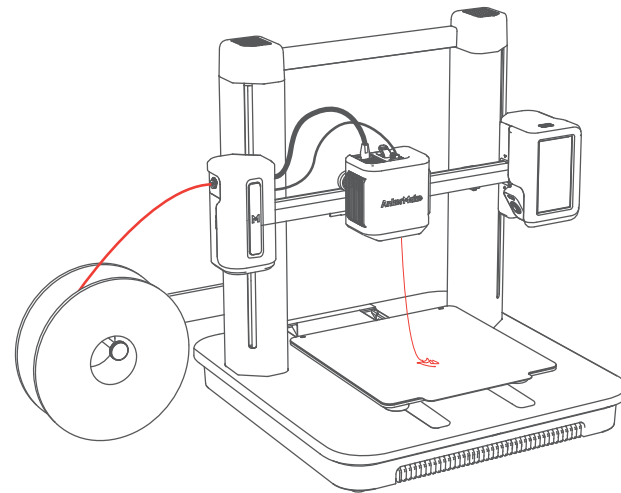



INSTALLATION DE ANKERMAKE SLICER

Pour une expérience d'impression optimale, téléchargez et installez AnkerMake Slicer sur votre ordinateur à partir de [fromankermake.com/software](https://www.fromankermake.com/software).

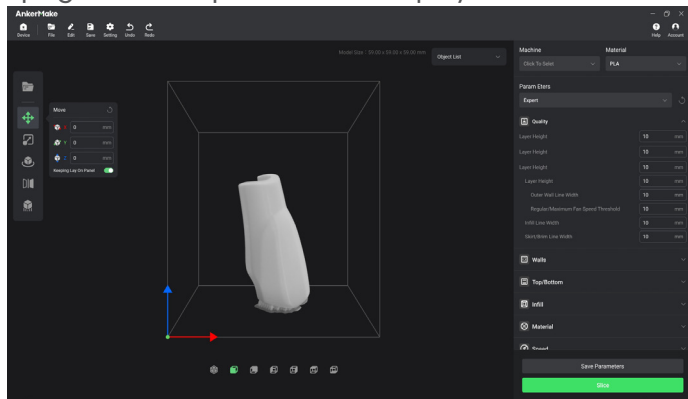
💡 Les capacités de reconnaissance de l'IA ne sont pas disponibles lorsque l'imprimante fonctionne avec d'autres logiciels de découpage 3D, tels que Cura et Simplify3D.



SÉCURITÉ

- Le cordon d'alimentation doit être raccordé à une prise de courant avec mise à la terre.
- L'alimentation doit être installée à proximité de l'équipement et la prise de courant doit être facilement accessible.
- Utilisez uniquement le cordon d'alimentation fourni par le fabricant. L'utilisation de cordon d'alimentation non autorisé peut présenter un danger et enfreindre l'autorisation du produit ainsi que la garantie.
- La prise du cordon d'alimentation est considérée comme le dispositif de déconnexion. Une fois débranché, le produit est considéré comme déconnecté de la source d'alimentation.
- N'utilisez pas l'appareil dans un environnement où la température est trop élevée ou trop faible. N'exposez jamais l'appareil à un fort ensoleillement ou à un environnement humide.
- La plage de températures idéale pour le produit et ses accessoires est comprise entre 15 °C et 35 °C.
- Il est recommandé d'alimenter l'appareil dans un environnement dont la température est comprise entre 15 °C et 25 °C.
- Lors de l'alimentation, placez l'appareil dans un environnement ayant une température ambiante normale et une bonne ventilation.
- Cet équipement n'est pas adapté à une utilisation dans des endroits où des enfants sont susceptibles d'être présents. Cet équipement n'est pas destiné à être utilisé par des enfants.
-  Pièces mobiles. Tenir les parties du corps éloignées des pièces mobiles.
-  ATTENTION Pièces chaudes. Ne pas toucher.
- N'utilisez pas le produit d'une autre manière que celle décrite ici afin d'éviter des blessures ou des dommages matériels.
- L'utilisateur doit se conformer aux lois et réglementations des pays et régions dans lesquels se trouve (est utilisé) l'équipement, respecter l'éthique professionnelle, prêter attention aux obligations de sécurité et interdire strictement l'utilisation de nos produits ou équipements à des fins illégales. Notre société ne sera en aucun cas responsable de la responsabilité légale des contrevenants.

AVIS

Avis (Europe et Royaume-Uni)



Ce produit est conforme aux exigences en matière d'interférences radio de la Communauté européenne.

Déclaration de conformité

Anker Innovations Limited déclare par le présent document que cet appareil est conforme aux exigences essentielles et aux autres dispositions pertinentes de la directive 2014/53/EU. Pour consulter la déclaration de conformité, consultez le site web suivant : <https://ankermake.com>.



Ce produit est conforme aux exigences du Royaume-Uni en matière d'interférences radio

Déclaration de conformité

Par la présente, Anker Innovations Limited déclare que ce dispositif est conforme au Règlement sur les équipements radio de 2017 (SI 2017/1206). Le texte intégral de la déclaration de conformité pour le Royaume-Uni est disponible à l'adresse suivante : <https://ankermake.com>.

Informations relatives à l'exposition aux radiofréquences :

La limite d'exposition maximale autorisée (norme MPE) a été calculée sur la base d'une distance de 20 centimètres entre l'appareil et le corps. Pour assurer la conformité aux exigences en matière d'exposition aux radiofréquences, utilisez le produit de manière à maintenir une distance de 20 cm entre l'appareil et le corps.

Bandes de fréquences et puissance comme ci-dessous :

Fonction	Bandes	Fréquence de fonctionnement	Puissance maximale
Wi-Fi	2,4 GHz	2 412-2 472 MHz	EIRP 19,10 dBm
Bluetooth	2,4 GHz	2402-2480 MHz	EIRP 8,0 dBm

L'importateur suivant est la partie responsable (contact pour les questions européennes) :

Anker Innovations Deutschland GmbH | Georg-Muche-Strasse 3, 80807 Munich, Allemagne

L'importateur suivant est la partie responsable (contact pour les questions relatives au Royaume-Uni) :

Anker Technology (UK) Limited | GNR8, 49 Clarendon Road, Watford, Hertfordshire, WD17 1HP, United Kingdom



Votre produit a été conçu et fabriqué avec des matériaux et des composants de haute qualité. Ceux-ci peuvent être recyclés et réutilisés.



Ce symbole signifie que le produit ne doit pas être jeté avec les déchets ménagers, mais doit être transmis à un établissement de collecte adapté pour permettre son recyclage. Une élimination et un recyclage appropriés contribuent à protéger les ressources naturelles, la santé humaine et l'environnement. Pour en savoir plus sur l'élimination et le recyclage de ce produit, contactez votre municipalité, le service d'élimination des déchets ou le magasin où vous avez acheté ce produit.

DESCRIZIONE DEL PRODOTTO

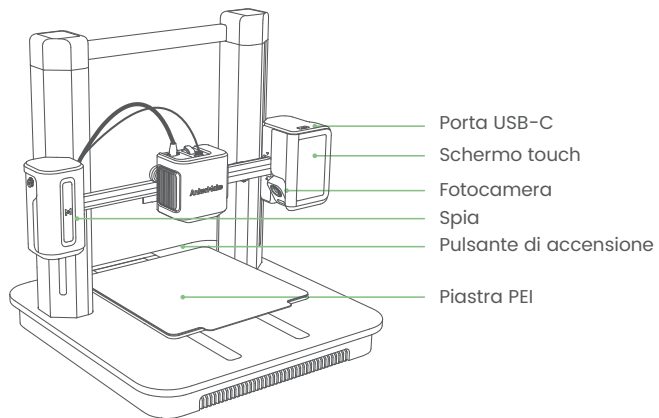

Spia*	Descrizione
Arancione lampeggiante lentamente	Riscaldamento
Verde che si affievolisce ripetutamente	Stampa
Rosso lampeggiante	È scattato un allarme

* Per ulteriori informazioni sullo stato della spia, visitare il sito Web <https://www.ankermake.com>.
Nome del prodotto: AnkerMake M5 Modello: V8111

MONTAGGIO DELLA STAMPANTE

Cosa serve

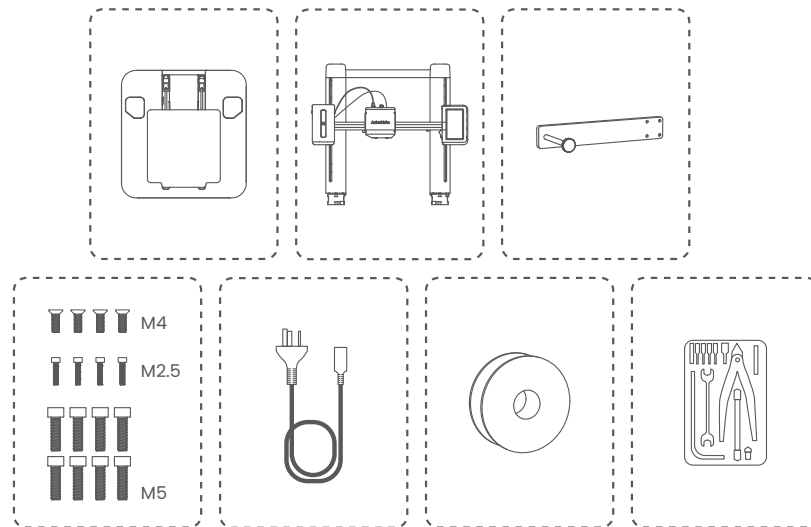

FASE 1. Installazione del telaio del cavalletto

1. Aprire la confezione, quindi posizionare a terra la copertura in espanso.

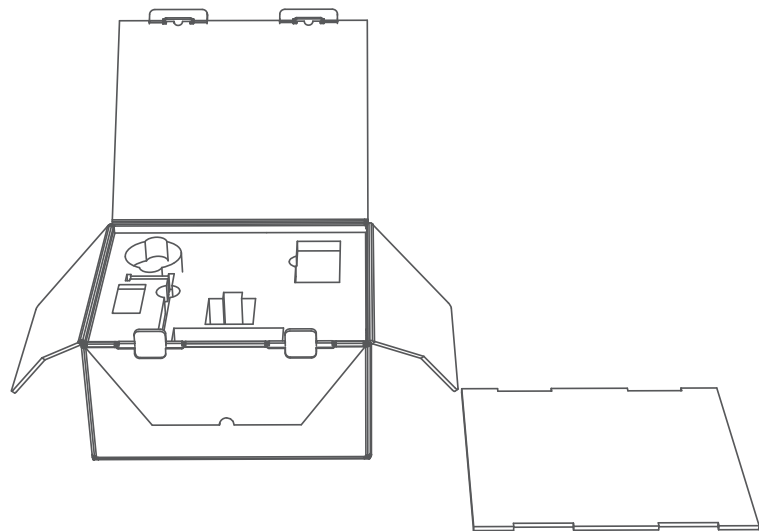

097 IT

2. Estrarre tutti gli accessori dall'imballaggio in espanso, quindi posizionare a terra la protezione in espanso per utilizzarla come supporto.

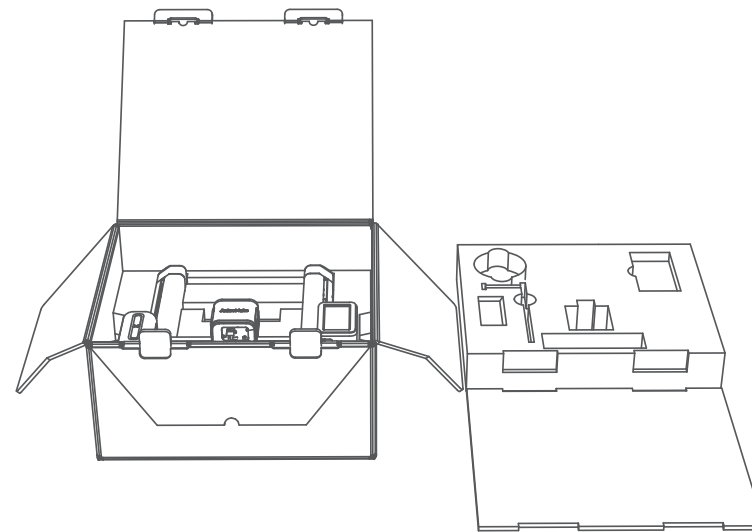

IT 098

3. Estrarre il telaio del cavalletto con la protezione in espanso e posizionarlo sul supporto in espanso.

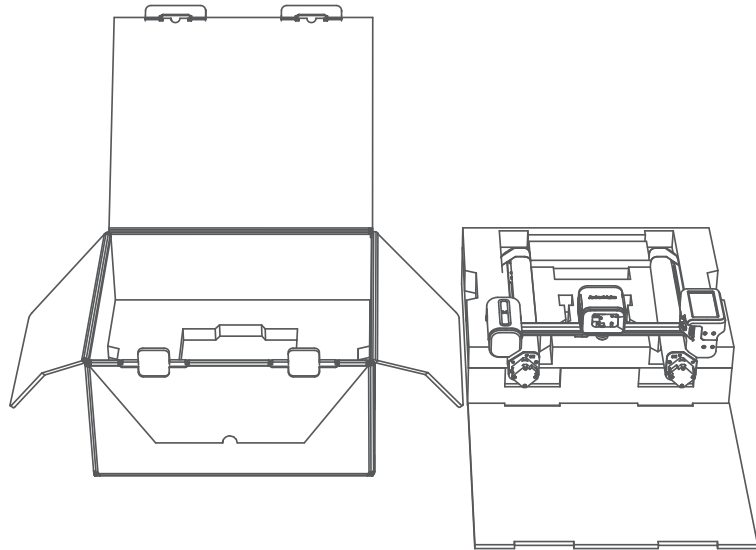

4. Estrarre il telaio del cavalletto dall'imballaggio in espanso, quindi rimontarlo come mostrato di seguito.

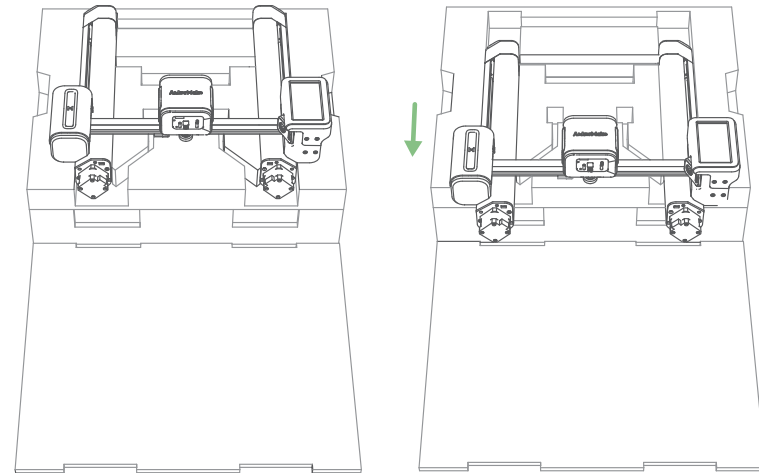

5. Staccare il coperchio inferiore dalla piattaforma.

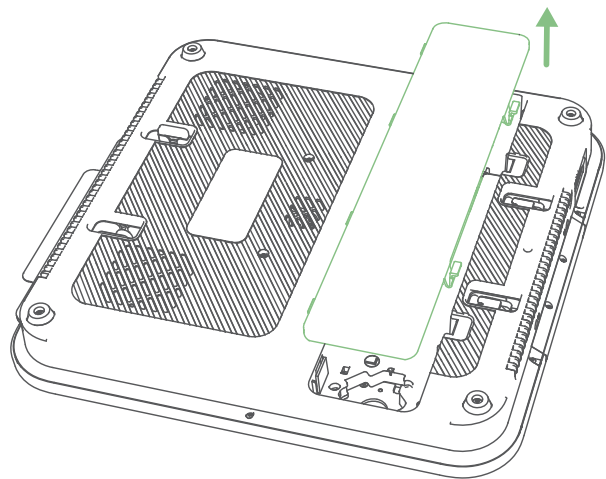

6. Montare la piattaforma attraverso i fori.

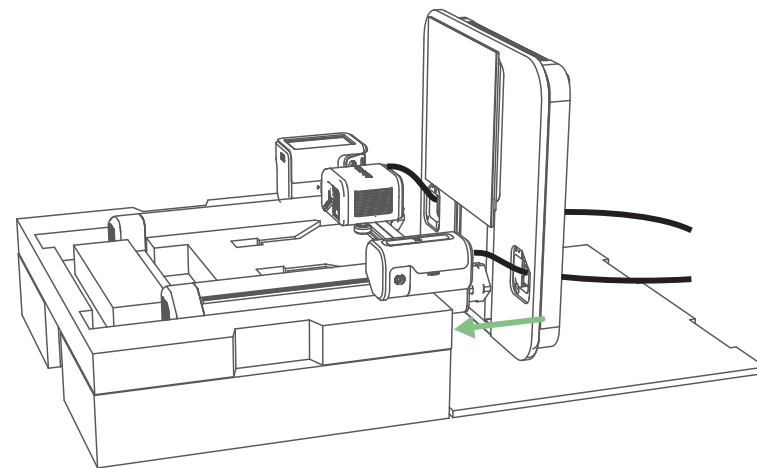

7. Fissare le viti nella piattaforma.

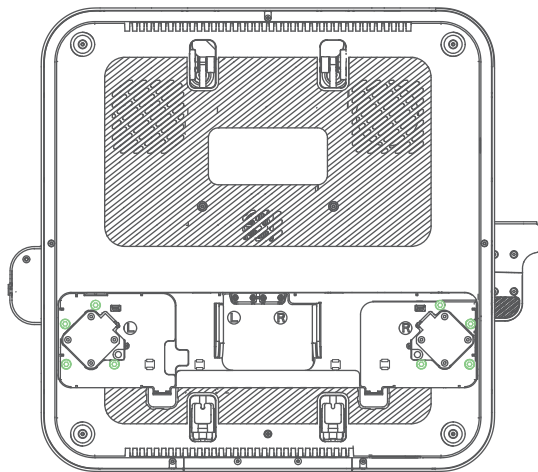

⊙ M5

FASE 2. Cablaggio

1. Collegare i cavi del motore.

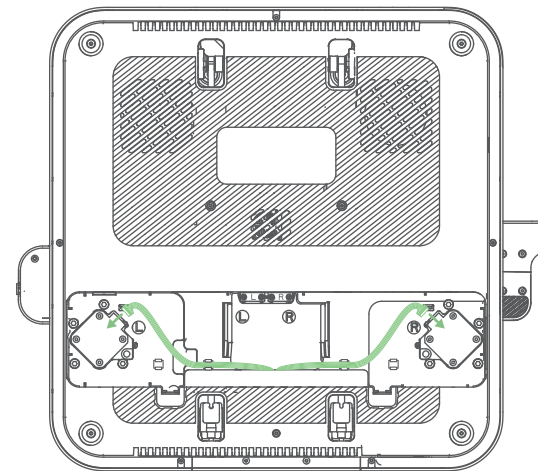

2. Collegare e fissare i cavi USB-C con le viti.

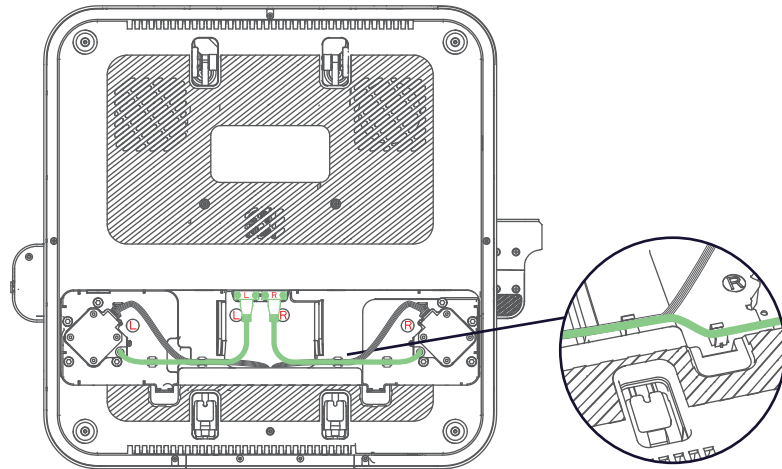

⊙ M2.5

3. Rimettere il coperchio inferiore sulla piattaforma.

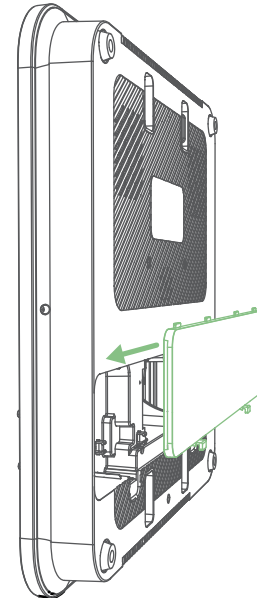

FASE 3. Installazione del supporto del filamento

Fissare il supporto del filamento con le viti.

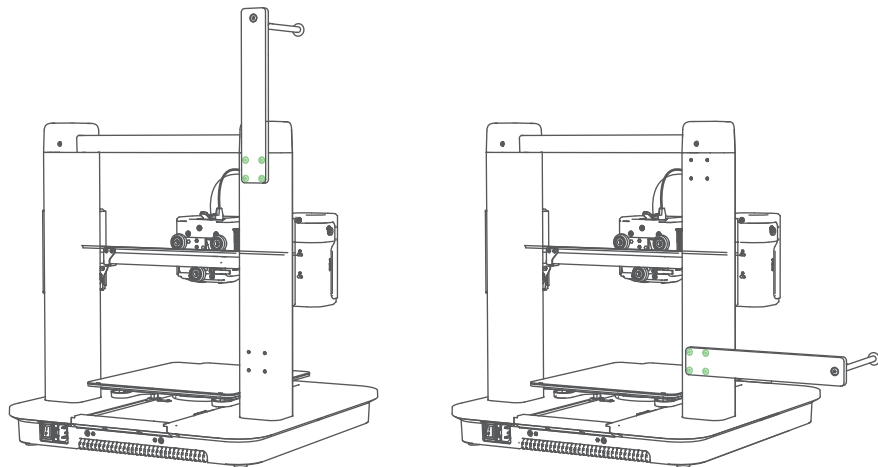

⊙ M4

Opzione 1

Opzione 2

FASE 4. Collegamento all'alimentazione

1. Collegare la stampante a una presa di corrente con il cavo di alimentazione, quindi accendere la stampante.

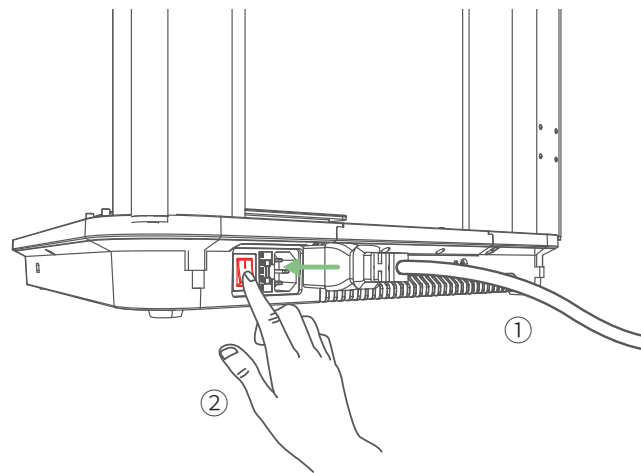

2. Seguire le istruzioni sullo schermo touch per completare la configurazione iniziale.

Configurazione del sistema

1. Scaricare e installare l'app AnkerMake e registrarsi per un account.



2. Seguire le istruzioni visualizzate per aggiungere la stampante all'elenco dei dispositivi e collegarla al Wi-Fi.

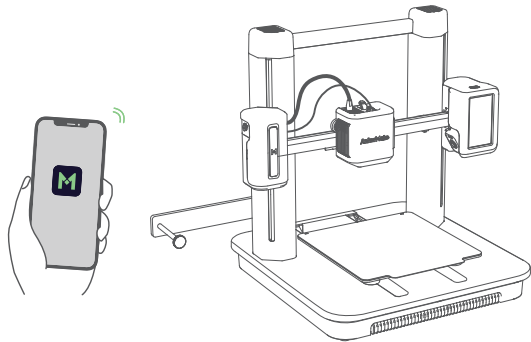

LIVELLAMENTO DEL LETTO RISCALDATO

Sullo schermo touch, selezionare **Controllo** > **Livellamento automatico** per livellare il letto riscaldato.

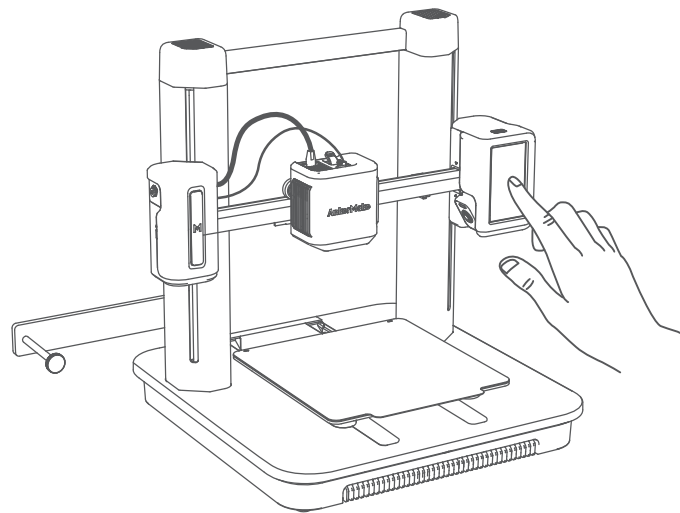

CARICAMENTO DEL FILAMENTO

1. Posizionare il filamento sul supporto.

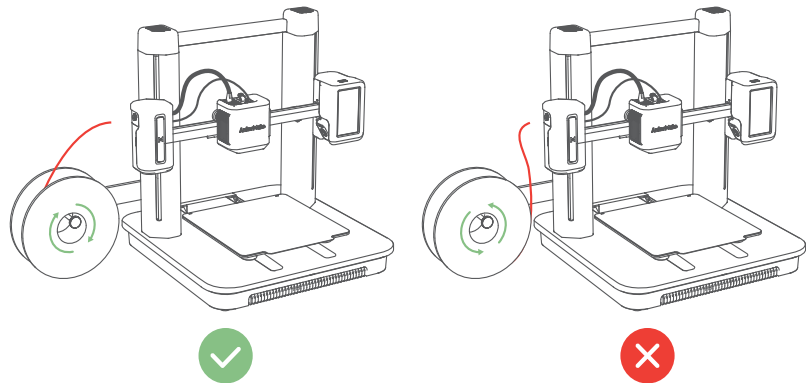

2. Tagliare la punta del filamento a un'angolazione di 45°.

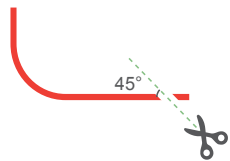

3. Inserire il filamento finché non raggiunge l'estrusore. Poi tenere premuto il pulsante sopra l'estrusore mentre si continua a inserire il filamento. Fermarsi quando si sente una certa resistenza.

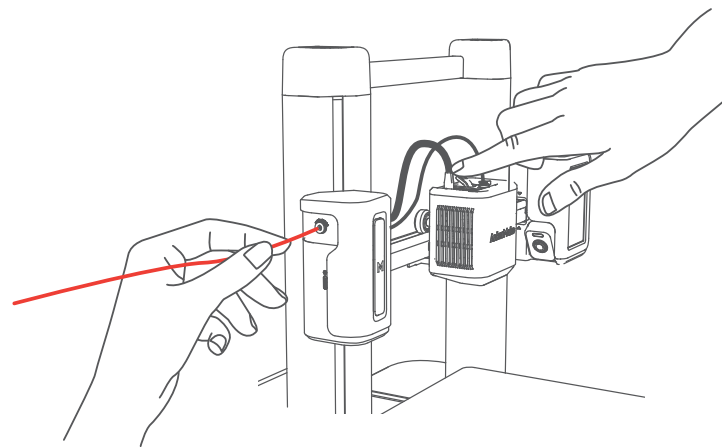

4. Sullo schermo touch, toccare **Control > Carico > Estrusione**.
Attendere finché il filamento non fuoriesce dall'ugello, quindi toccare **Stop**.

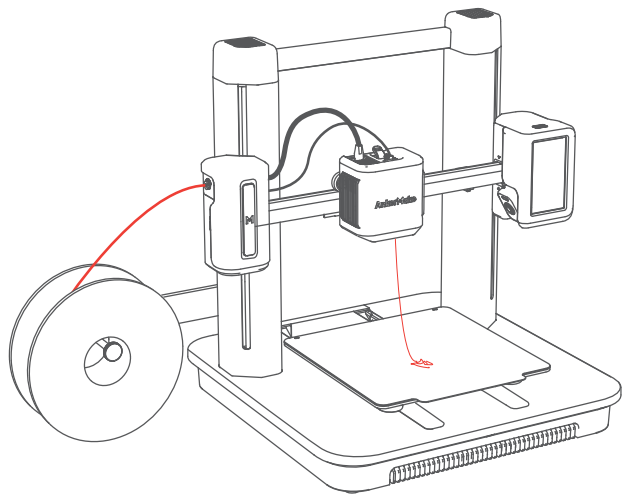



INSTALLAZIONE DI ANKERMAKE SLICER

Per ottenere la migliore esperienza di stampa, scaricare e installare AnkerMake Slicer sul proprio computer dal sito Web ankermake.com/software.

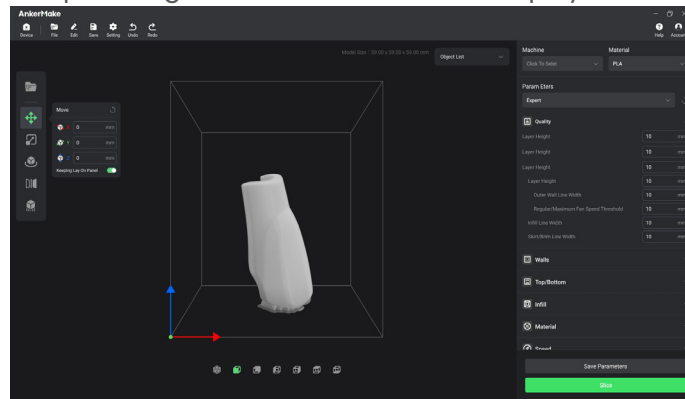
💡 Le funzionalità di riconoscimento dell'intelligenza artificiale non sono disponibili quando la stampante viene utilizzata con altri software per il taglio in 3D, come Cura e Simplify3D.



SICUREZZA

- Il cavo di alimentazione deve essere collegato a una presa con messa a terra.
- L'alimentatore deve essere installato vicino all'apparecchiatura e la presa deve essere facilmente accessibile.
- Utilizzare solo il caricabatterie fornito dal produttore. L'utilizzo di cavi di alimentazione non autorizzato potrebbe causare pericolo e violare l'autorizzazione del prodotto e i termini di garanzia.
- La spina del cavo di alimentazione è considerata come dispositivo di scollegamento. Una volta scollegato, il prodotto è considerato scollegato dalla fonte di alimentazione.
- Non utilizzare il dispositivo in un ambiente con temperatura eccessivamente alta o bassa. Non esporre il dispositivo alla luce solare diretta o ad ambienti troppo umidi.
- La temperatura più idonea per il prodotto e i relativi accessori è compresa tra 15°C e 35°C.
- Si consiglia di alimentare il dispositivo in un ambiente con una temperatura compresa tra 15°C e 25°C.
- Durante l'alimentazione, posizionare il dispositivo in un ambiente con una temperatura ambiente normale e una buona ventilazione.
- Questa apparecchiatura non è adatta per l'uso in luoghi in cui possono essere presenti bambini. Questa apparecchiatura non è destinata all'uso da parte di bambini.
-  Parti in movimento. Allontanare le parti del corpo dalle parti in movimento.
-  ATTENZIONE Parti calde. Non toccare.
- Non utilizzare il prodotto in modi diversi da quanto qui descritto al fine di evitare lesioni personali o materiali.
- L'utente è tenuto a rispettare le leggi e le normative dei paesi e delle regioni corrispondenti in cui l'apparecchiatura è ubicata (utilizzata), attenersi all'etica professionale, prestare attenzione agli obblighi di sicurezza e vietare rigorosamente l'uso dei nostri prodotti o delle nostre apparecchiature per scopi illeciti. La responsabilità legale dei trasgressori non potrà essere in alcun caso attribuita alla nostra azienda.

AVVISO

Avviso (Europa e Regno Unito)

 Questo prodotto è conforme ai requisiti della Comunità europea relativi alle interferenze radio.

Dichiarazione di conformità

Con il presente documento, Anker Innovations Limited dichiara che questo dispositivo è conforme ai requisiti fondamentali e alle altre disposizioni correlate previste dalla direttiva 2014/53/UE. Per la dichiarazione di conformità, visitare il sito Web: <https://ankermake.com>.



Questo prodotto è conforme ai requisiti sulle interferenze radio del Regno Unito

Dichiarazione di conformità

Con la presente, Anker Innovations Limited dichiara che questo dispositivo è conforme alle normative sulle apparecchiature radio 2017 (SI 2017/1206). Il testo completo della dichiarazione di conformità del Regno Unito è disponibile al seguente indirizzo Internet: <https://ankermake.com>.

Informazioni sull'esposizione a radiofrequenze:

Il livello di esposizione massima consentita (MPE) è stato calcolato sulla base di una distanza di 20 cm tra il dispositivo e il corpo umano. Per mantenere la conformità ai requisiti di esposizione alle radiofrequenze, utilizzare un prodotto che mantenga una distanza di 20 cm tra il dispositivo e il corpo umano.

Di seguito sono riportate le bande di frequenza e la potenza:

Funzione	Bande	Frequenza operativa	Potenza max.
Wi-Fi	2,4 GHz	2412-2472 MHz	EIRP 19,10 dBm
Bluetooth	2,4 GHz	2402-2480 MHz	EIRP 8,0 dBm

Il seguente importatore è la parte responsabile (contratto esclusivamente per le questioni pertinenti all'UE):

Anker Innovations Deutschland GmbH | Georg-Muche-Strasse 3, 80807 Monaco, Germania

Il seguente importatore è la parte responsabile (contratto esclusivamente per le questioni pertinenti al Regno Unito):

Anker Technology (UK) Limited | GNR8, 49 Clarendon Road, Watford, Hertfordshire, WD17 1HP, United Kingdom



Il prodotto è stato progettato e realizzato con materiali e componenti di alta qualità, che possono essere riciclati e riutilizzati.



Questo simbolo indica che il prodotto non deve essere smaltito tra i rifiuti domestici e deve essere consegnato presso un centro di raccolta per il riciclo. Un corretto smaltimento e riciclaggio aiuta a proteggere le risorse naturali, la salute umana e l'ambiente. Per ulteriori informazioni sullo smaltimento e il riciclo, contattare il comune locale, il servizio di smaltimento o il negozio in cui è stato acquistato il prodotto.

IN EEN OOGOPSLAG

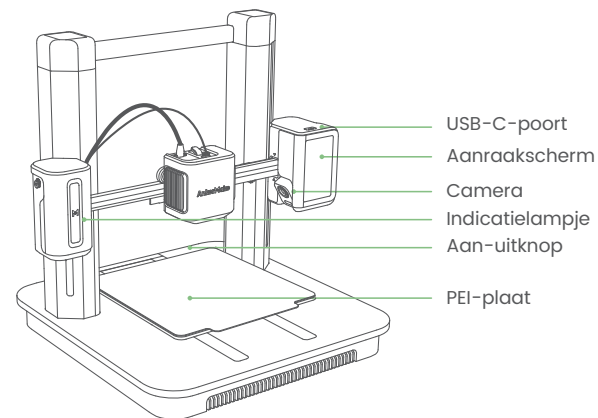

Indicatielampje*	Beschrijving
Knippert langzaam oranje	Aan het opwarmen
Pulseert groen	Aan het printen
Knippert rood	Alarm

* Ga voor meer informatie over de status van het indicatielampje naar <https://www.ankermake.com>.

Productnaam: AnkerMake M5 Model: V8111

DE PRINTER MONTEREN

U hebt nodig:

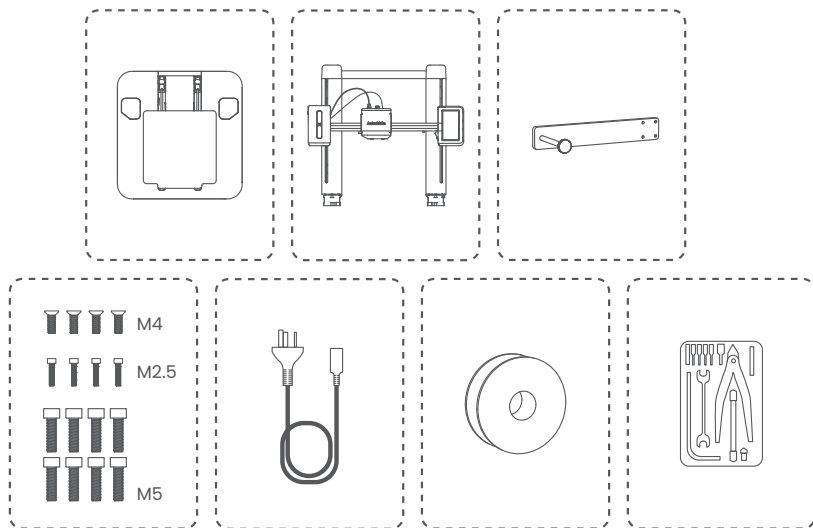

STAP 1. De brug installeren

1. Open de doos en plaats de schuimrubberen afdekking op de grond.

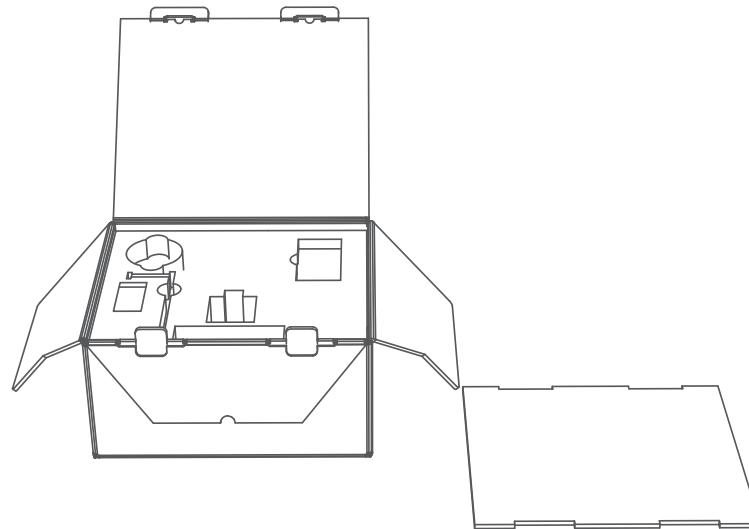

2. Haal alle accessoires uit het schuim en plaats het beschermingsschuim op de grond als ondersteuning.

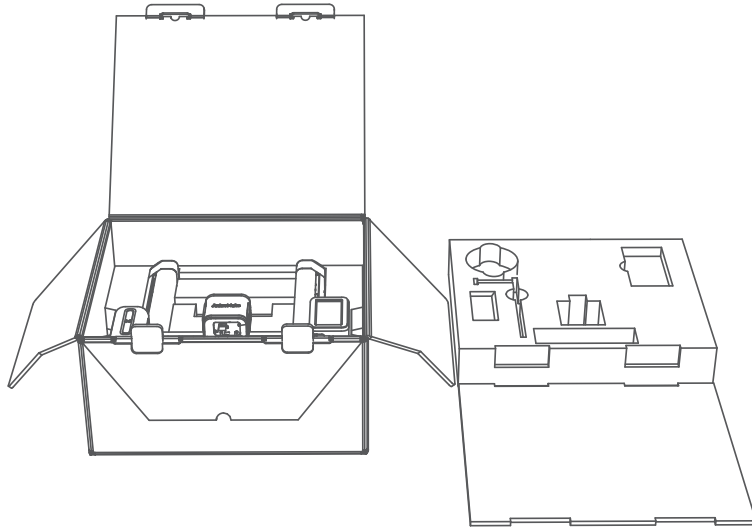

3. Haal de brug uit zijn beschermingsschuim en plaats het op het ondersteuningsschuim.

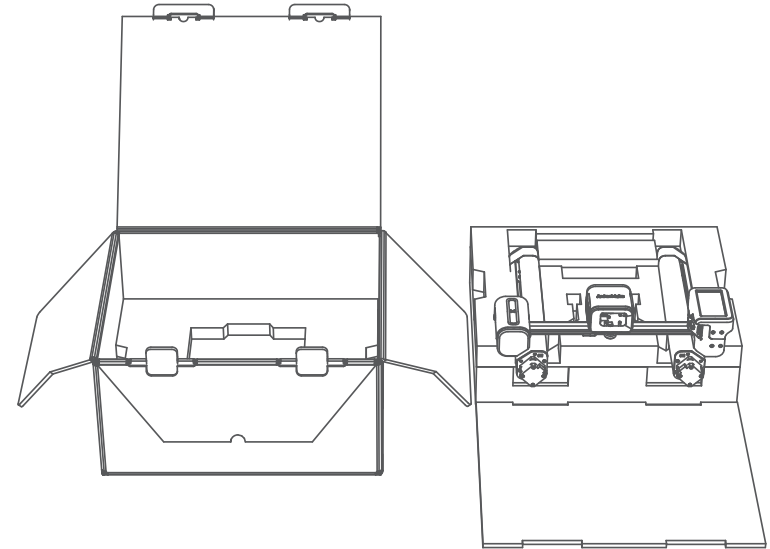

4. Haal de brug uit het verpakkingsschuim en leg het terug, zoals hieronder is afgebeeld.

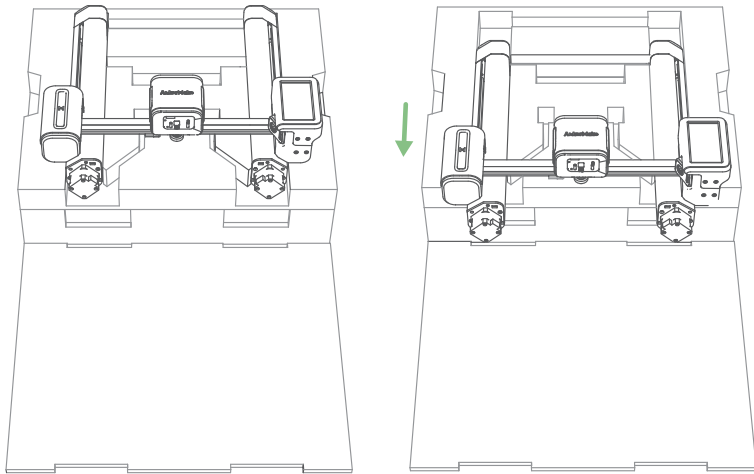

5. Verwijder het paneel aan de onderkant van het platform.

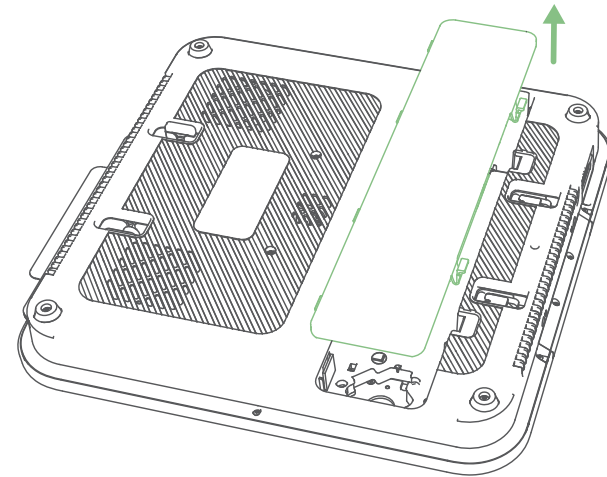

7. Draai de schroeven in het platform vast.

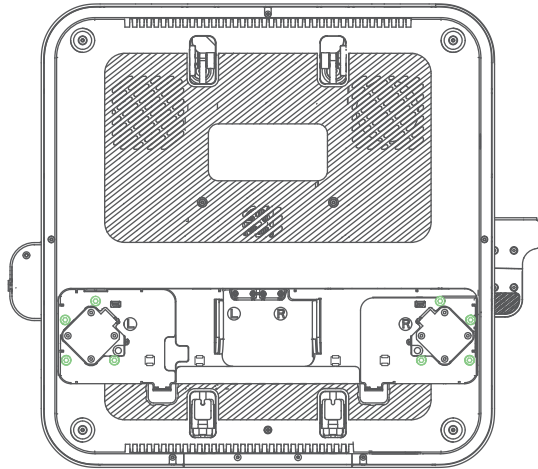

⊙ M5

6. Monteer het platform door de gaten.

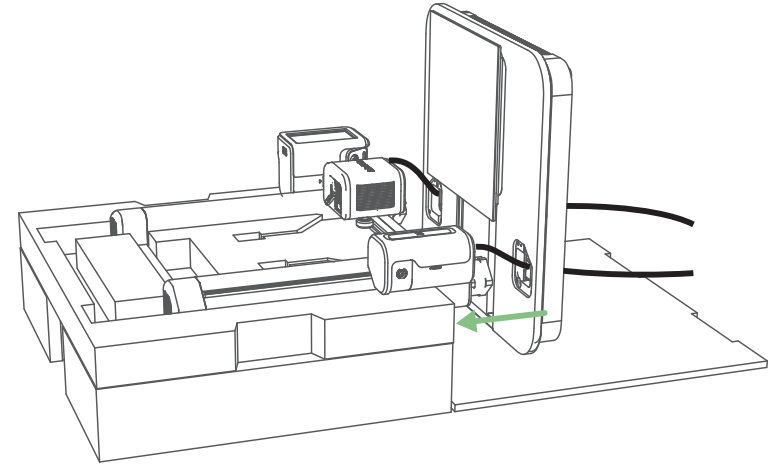

STAP 2. Bedrading

1. Sluit de motordraden aan.

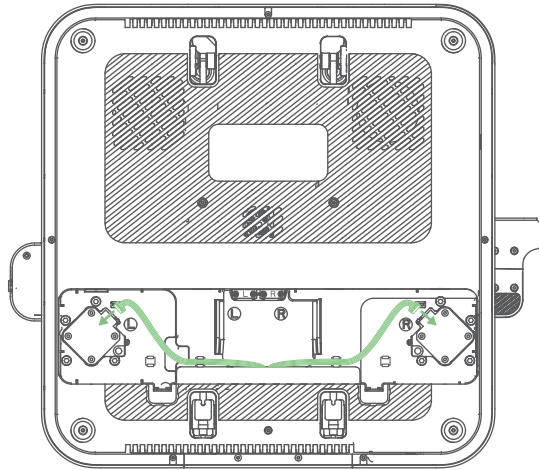

2. Sluit de USB-C-kabels aan en zet ze met schroeven vast.

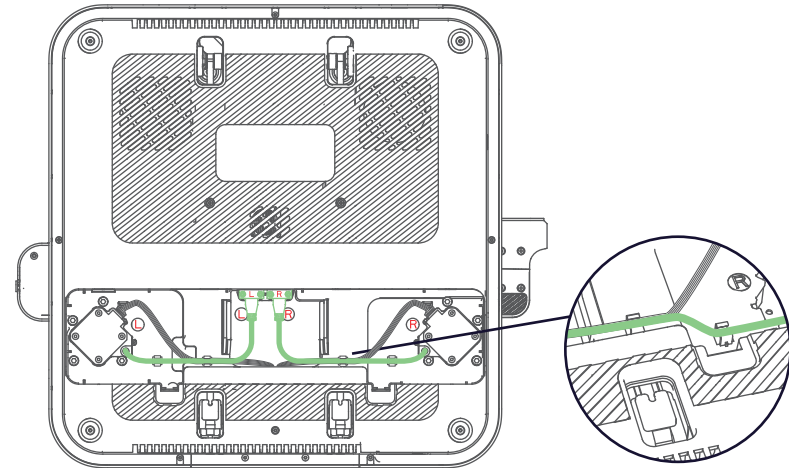

⊙ M2.5

3. Plaats het paneel terug in de onderkant van het platform.

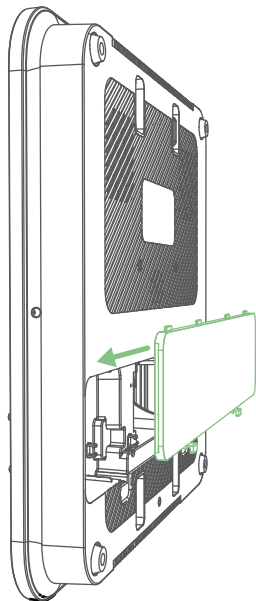

STAP 3. De filamenthouder installeren

Zet de filamenthouder met schroeven vast.

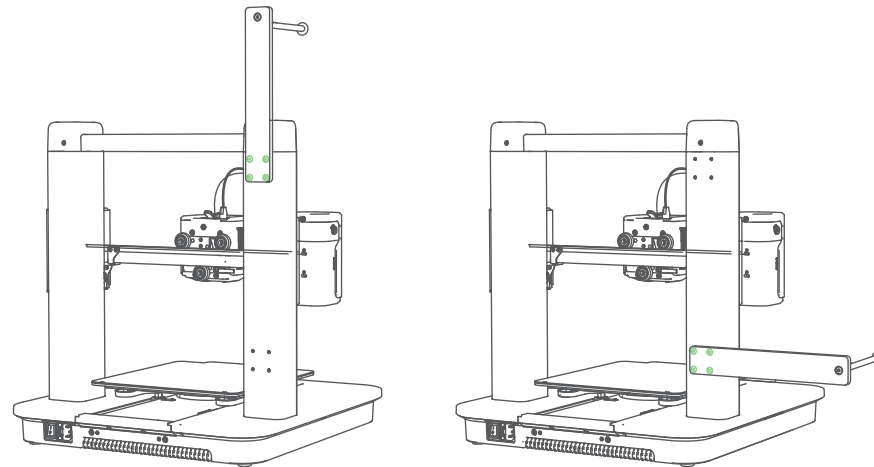

⊙ M4

STAP 4. Op de voeding aansluiten

1. Sluit de printer met het snoer aan op een stopcontact en zet de printer aan.

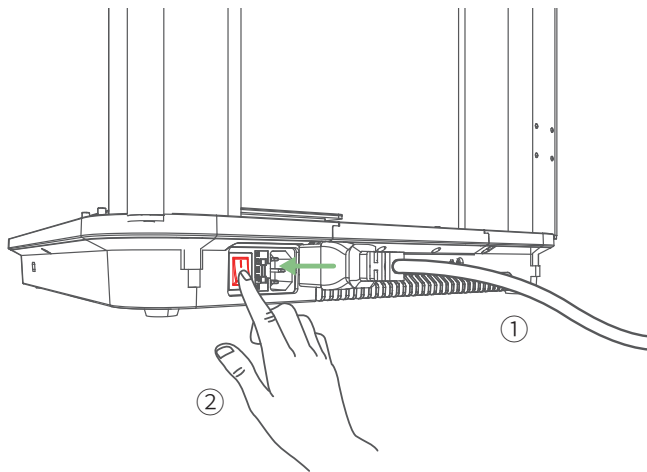

2. Volg de instructies op het aanraakscherm om het instellen te voltooien.

Het systeem instellen

1. Download en installeer de AnkerMake-app en meld u aan voor een account.



2. Volg de instructies op het scherm om de printer aan uw apparatenlijst toe te voegen en verbinding te maken met wifi.

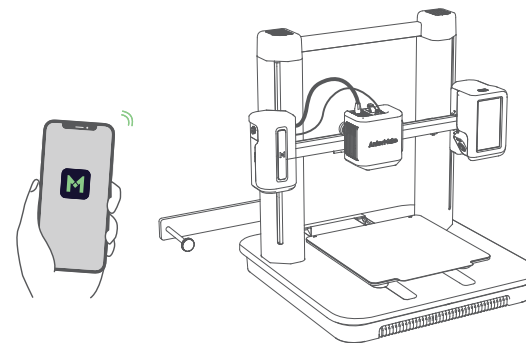

DE WARMTEPLAAT RECHTZETTEN

Ga op het aanraakscherm naar **Bediening** > **Automatisch rechtzetten** om de warmteplaat waterpas te stellen.

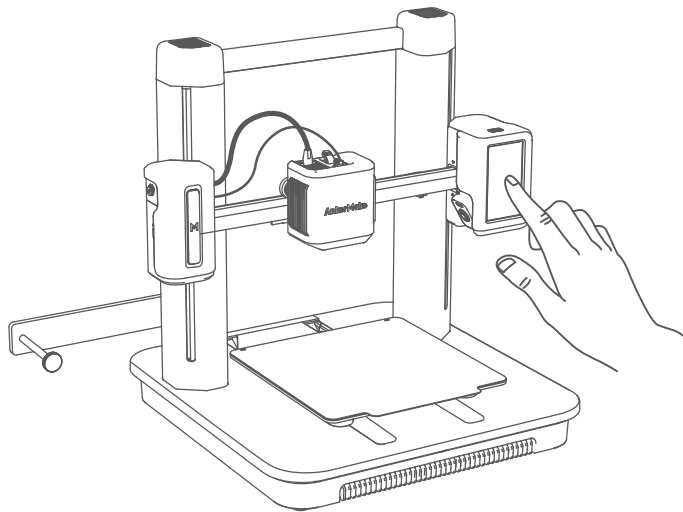

HET FILAMENT LADEN

1. Steek het filament in de houder.

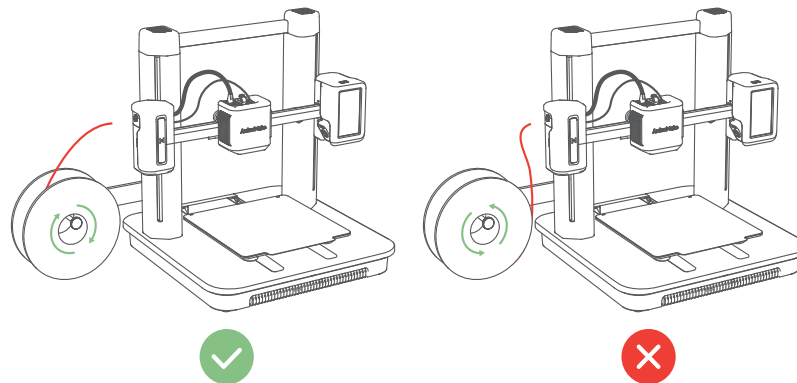

2. Knip de punt van het filament in een hoek van 45° af.

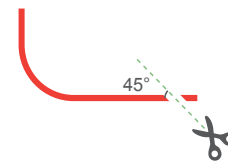

3. Duw het filament verder, totdat het de extruder bereikt. Houd vervolgens de knop bovenop de extruder ingedrukt terwijl u doorgaat met het inbrengen van het filament. Stop wanneer u enige weerstand voelt.

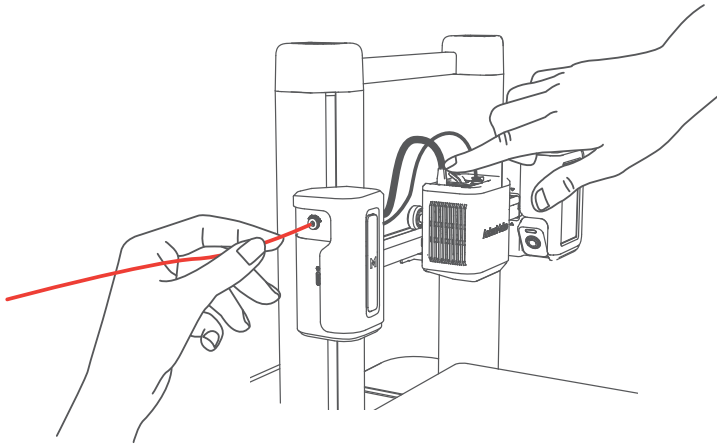

4. Ga op het aanraakscherm naar **Bediening** > **Laden** > **Extruderen**. Wacht tot het filament uit het mondstuk komt en druk vervolgens op **Stop**.

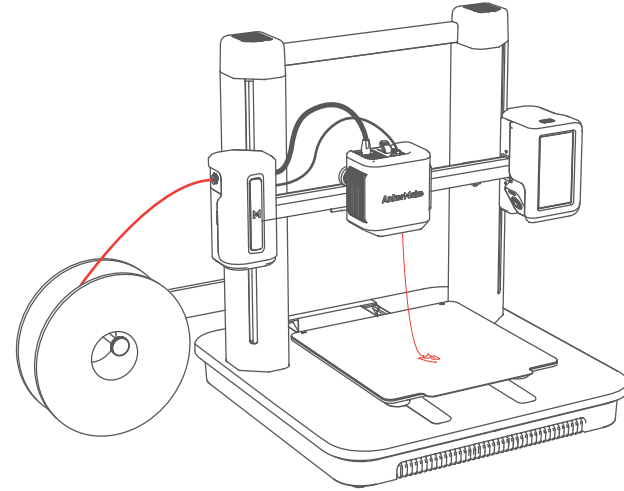

ANKERMAKE SLICER INSTALLEREN

Om het printen makkelijker te maken, installeert u AnkerMake Slicer (te downloaden van fromankermake.com/software) op uw computer.

 De mogelijkheden voor AI-herkenning zijn niet beschikbaar als de printer andere 3D-slicersoftware gebruikt, zoals Cura of Simplify3D.

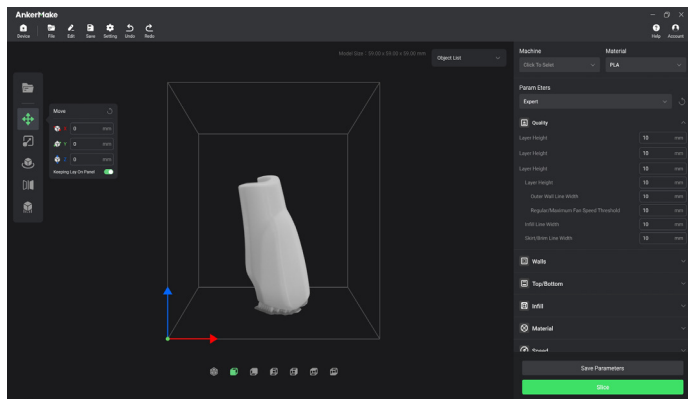

VEILIGHEID

- Het snoer moet worden aangesloten op een gearde contactdoos.
- De voeding moet in de buurt van het apparaat worden geplaatst en de contactdoos moet goed bereikbaar zijn.
- Gebruik alleen het door de fabrikant meegeleverde snoer. Het gebruik van een niet-geautoriseerd snoer kan gevaar opleveren en in strijd zijn met de goedkeuring van het product en de garantie.
- De stekker van het snoer wordt beschouwd als een uitschakelinrichting. Als de stekker uit het stopcontact is gehaald, wordt het product beschouwd als van de stroombron losgekoppeld.
- Gebruik het apparaat niet in een omgeving met een te hoge of te lage temperatuur. Stel het apparaat nooit bloot aan fel zonlicht of natte omgevingen.
- Het geschikte temperatuurbereik voor het product en zijn accessoires is 15 tot 35 °C.
- Het wordt aangeraden om de voeding van het apparaat te plaatsen in een omgeving met een temperatuurbereik van 15 ~ 25 °C.
- Als de voeding is aangesloten, moet u het apparaat plaatsen in een omgeving met een normale kamertemperatuur en goede ventilatie.
- Deze apparatuur is niet geschikt voor gebruik op locaties waar kinderen waarschijnlijk aanwezig zijn. Dit apparaat is niet bedoeld voor gebruik door kinderen.



Bewegende onderdelen. Houd lichaamsdelen uit de buurt van bewegende delen.



LET OP: Hete onderdelen. Niet aanraken.

- Gebruik het product niet anders dan in deze handleiding is beschreven om letsel of schade aan eigendommen te voorkomen.
- De gebruiker moet zich houden aan de wetten en regelgeving van de landen en regio's waar het apparaat zich bevindt (wordt gebruikt), zich houden aan de beroepsethiek, veiligheidsverplichtingen in acht nemen en het gebruik van onze producten of apparatuur voor illegale doeleinden ten strengste verbieden. Ons bedrijf is onder geen enkele omstandigheid verantwoordelijk voor de wettelijke aansprakelijkheid van overtreeders.

KENNISGEVING

Kennisgeving (Europa en Verenigd Koninkrijk)

 Dit product voldoet aan de EU-vereisten met betrekking tot radio-interferentie.

Verklaring van conformiteit

Hierbij verklaart Anker Innovations Limited dat dit apparaat voldoet aan de essentiële vereisten en andere relevante bepalingen van Richtlijn 2014/53/EU. De verklaring van conformiteit vindt u op de website: <https://ankermake.com>.

 Dit product voldoet aan de vereisten voor radio-interferentie van het Verenigd Koninkrijk.

Verklaring van conformiteit

Hierbij verklaart Anker Innovations Limited dat dit apparaat voldoet aan de bepalingen van de Radio Equipment Regulations 2017 (SI 2017/1206). De volledige tekst van de verklaring van conformiteit voor het VK is beschikbaar op de volgende website: <https://ankermake.com>.

Informatie over blootstelling aan RF:

Het MPE-niveau (Maximum Permissible Exposure) is berekend op basis van een afstand van $d=20$ cm tussen het apparaat en het menselijk lichaam. Zorg ervoor dat het apparaat minstens 20 cm verwijderd blijft van het menselijk lichaam om te voldoen aan de RF-blootstellingsnorm.

Frequentiebanden en vermogens als volgt:

Functie	Banden	Bedrijfsfrequentie	Max. vermogen
Wifi	2,4 GHz	2412 – 2472 MHz	EIRP 19,10 dBm
Bluetooth	2,4 GHz	2402-2480 MHz	EIRP 8,0 dBm

De volgende importeur is de verantwoordelijke partij (contactpartij voor EU):

Anker Innovations Deutschland GmbH | Georg-Muche-Strasse 3, 80807 München, Duitsland

De volgende importeur is de verantwoordelijke partij (contactpartij voor VK):

Anker Technology (UK) Limited | GNR8, 49 Clarendon Road, Watford, Hertfordshire, WD17 1HP, United Kingdom



Uw product is ontworpen en vervaardigd met hoogwaardige materialen en componenten, die kunnen worden gerecycled en hergebruikt.



Dit symbool betekent dat dit product niet mag worden weggegooid als huishoudelijk afval en moet worden ingeleverd bij een daarvoor bestemd inzamelpunt voor recycling. Door dit product op de juiste manier te verwijderen en te recyclen, draagt u bij aan de bescherming van natuurlijke hulpbronnen, de gezondheid van de mens en het milieu. Neem voor meer informatie over de verwijdering en recycling van dit product contact op met uw gemeente, het afvalverwijderingsbedrijf of de winkel waar u dit product hebt gekocht.

VISTA GERAL

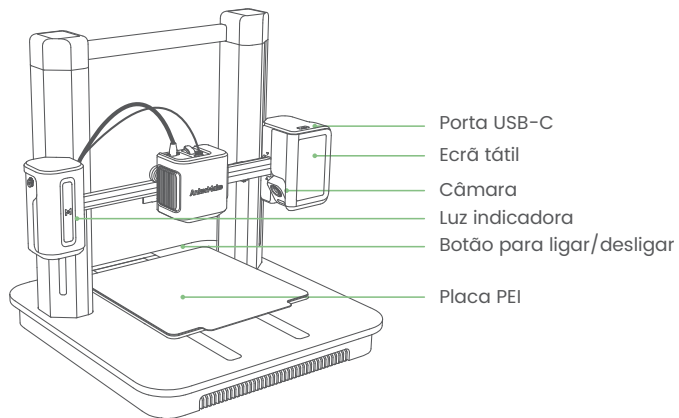

Luz indicadora*	Descrição
Laranja com intermitência lenta	A aquecer
Verde com desvanecimento repetido	A imprimir
Vermelho intermitente	Foi acionado um alarme

* Para mais informações sobre as luzes indicadoras, visite <https://www.ankermake.com>.
Nome do produto: AnkerMake M5 Modelo: V8111

MONTAGEM DA IMPRESSORA

Vai precisar de:

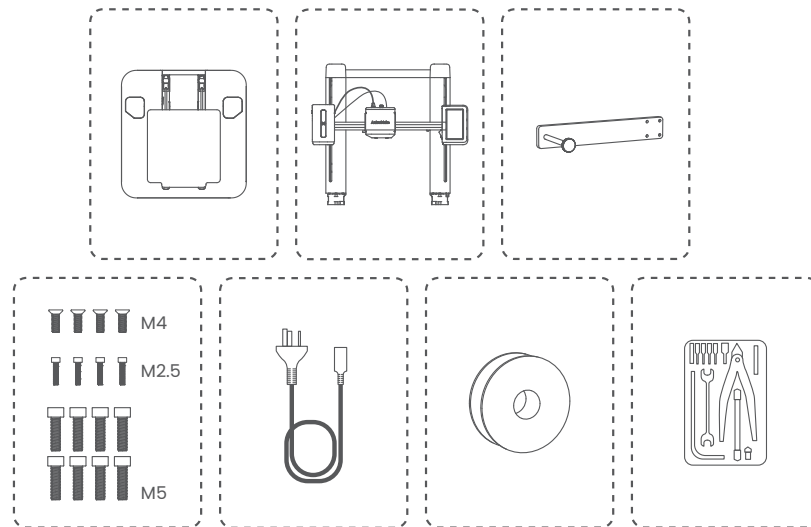

PASSO 1. Instalação da armação

1. Abra a caixa e coloque a cobertura de espuma no chão.

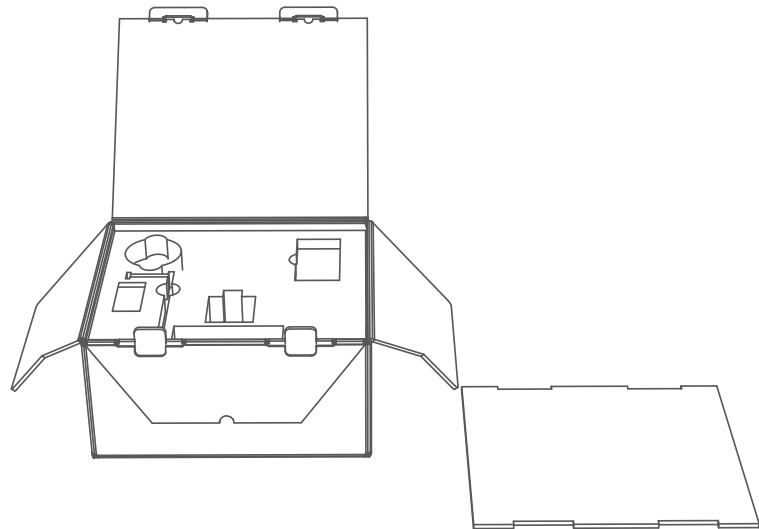

2. Retire todos os acessórios da espuma de proteção e coloque-a no chão para servir de base.

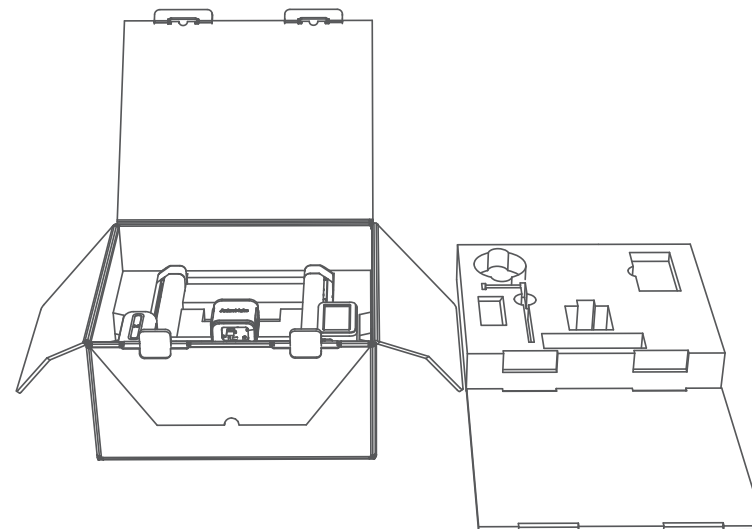

3. Retire a armação com a respetiva espuma de proteção e coloque-a sobre a base de espuma.

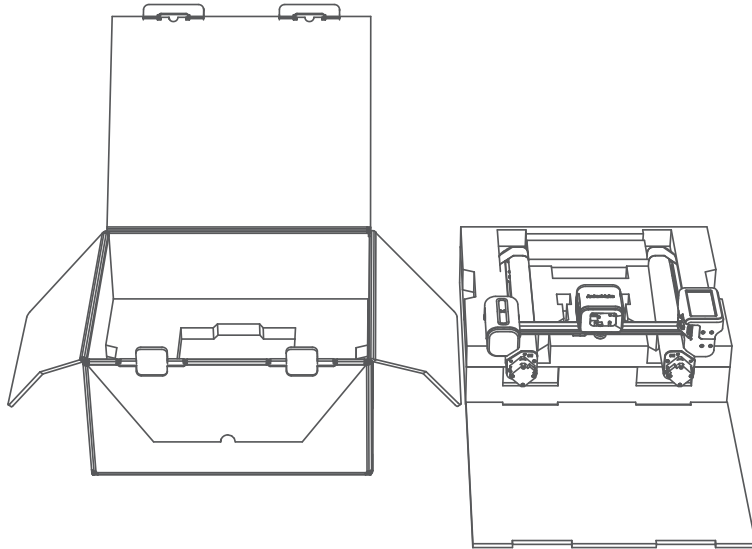

4. Retire a armação da espuma de embalagem e voltar a colocá-la como mostrado abaixo.

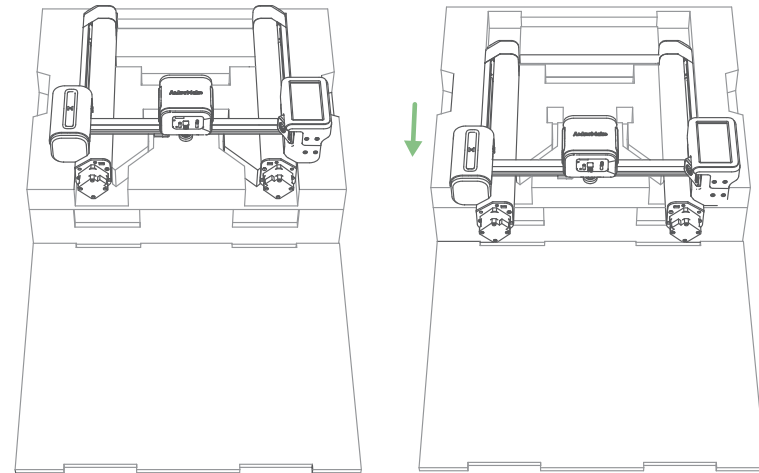

5. Retire a tampa inferior da plataforma.

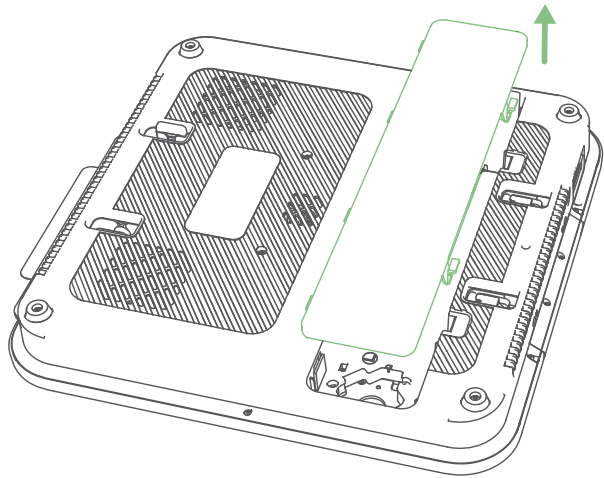

6. Monte a plataforma nos orifícios.

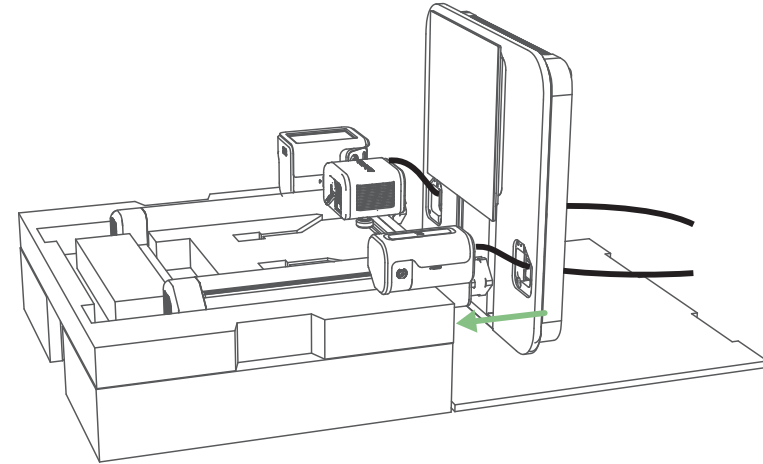

7. Aperte os parafusos na plataforma.

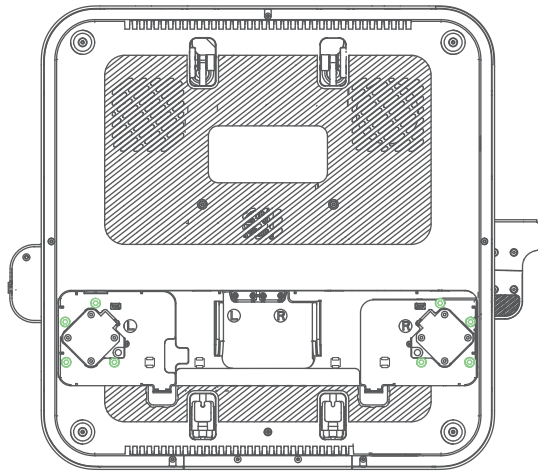

⊙ M5

PASSO 2. Cablagem

1. Ligue os fios do motor.

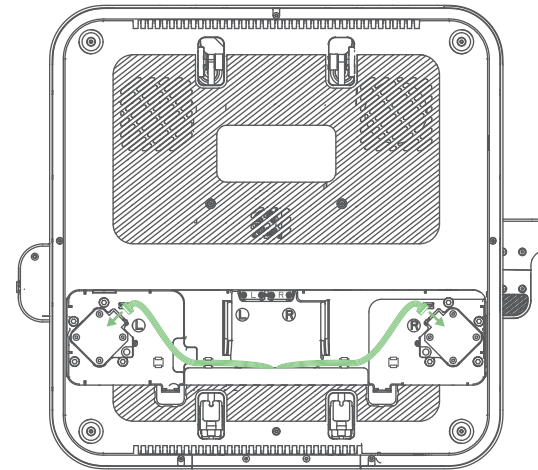

2. Ligue e prenda os cabos USB-C com parafusos.

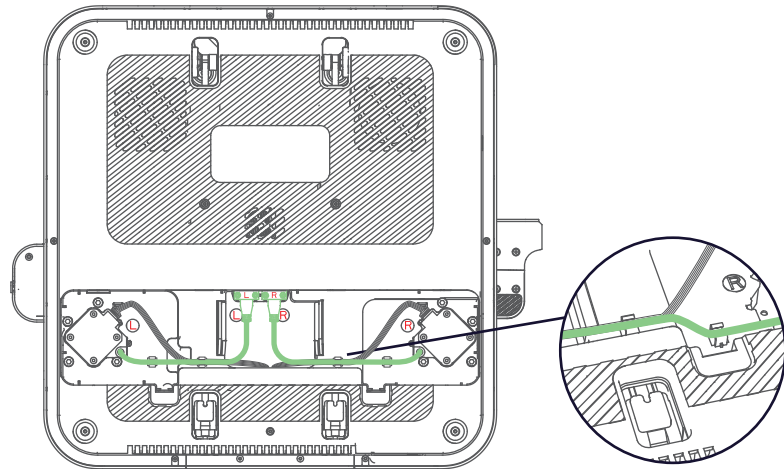

3. Volte a colocar a tampa inferior na plataforma.

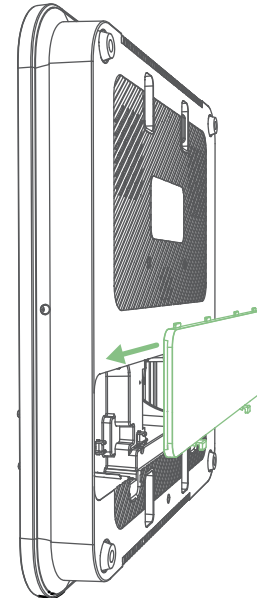

PASSO 3. Instalação do suporte de filamento

Fixe o suporte de filamento com parafusos.

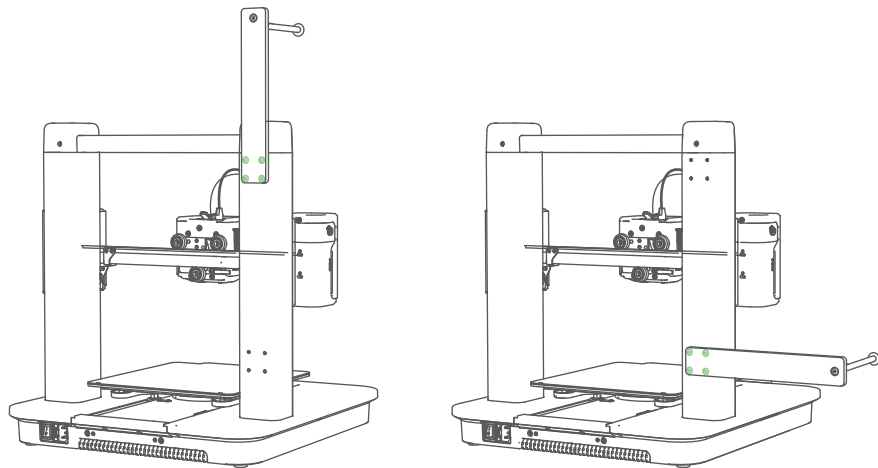

⊙ M4

Opção 1

Opção 2

PASSO 4. Ligação à corrente elétrica

1. Ligue com o cabo de alimentação a uma tomada elétrica e, em seguida, ligue a impressora.

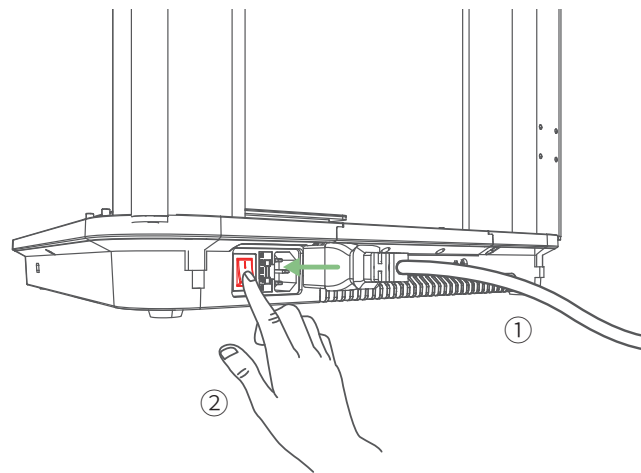

2. Siga as instruções no ecrã tátil para concluir a configuração inicial.

Configurar o sistema

1. Transfira e instale a aplicação AnkerMake e crie uma conta.



2. Siga as instruções no ecrã para adicionar a impressora à lista de dispositivos e ligue-a à rede Wi-Fi.

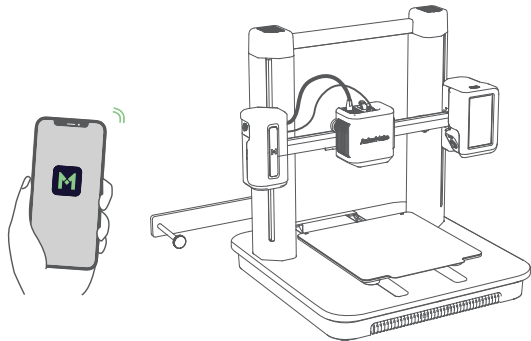

NIVELAMENTO DA BASE DE AQUECIMENTO

No ecrã tátil, aceda a **Controlo** > **Nivelamento automático** para nivelar a base de aquecimento.

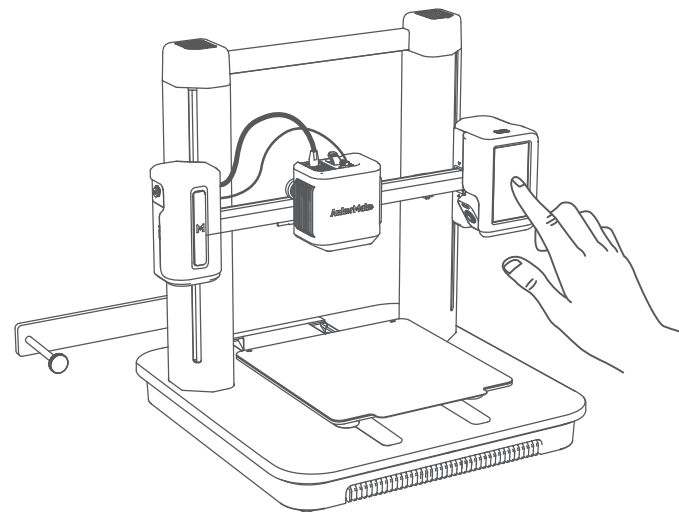

CARREGAMENTO DO FILAMENTO

1. Coloque o filamento no suporte.

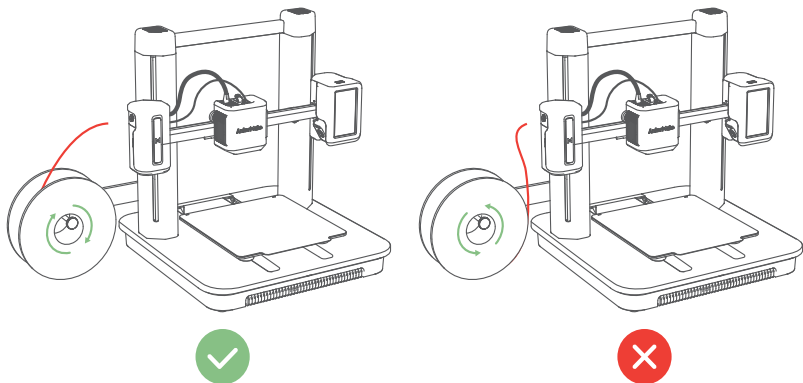

2. Corte a extremidade do filamento num ângulo de 45°.

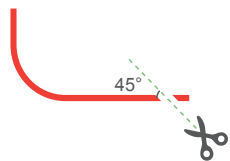

3. Introduza o filamento até alcançar o extrusor. Em seguida, mantenha o botão no topo do extrusor pressionado e continue a introduzir o filamento. Pare quando sentir resistência.

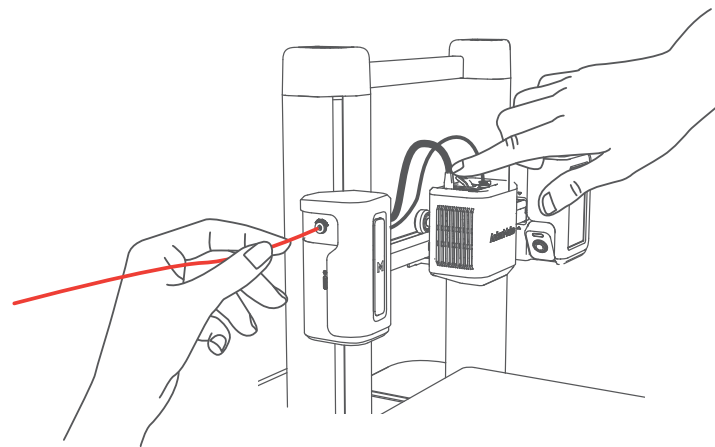

4. No ecrã tátil, toque em **Carregar** em **Control** > **Extrusão**.
Aguarde até o filamento sair do bocal e toque em Parar.

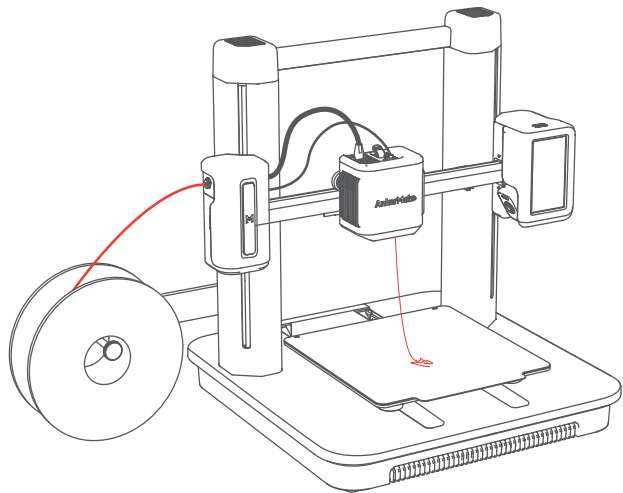



INSTALAÇÃO DO ANKERMAKE SLICER

Para obter a melhor experiência de impressão, descarregue e instale o AnkerMake Slicer no computador: fromankermake.com/software.

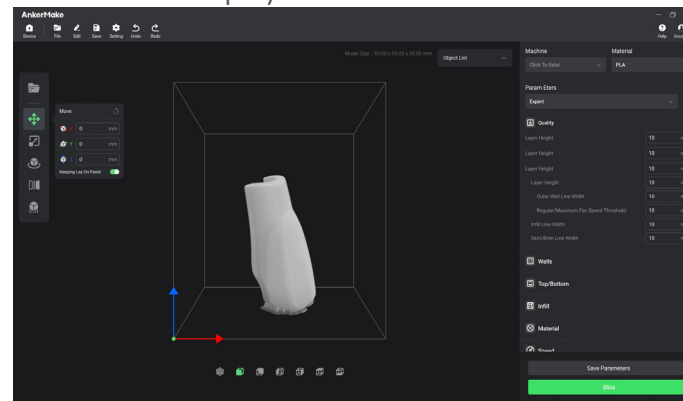
💡 As capacidades de reconhecimento de IA não estarão disponíveis se utilizar a impressora com outro software de impressão 3D, como o Cura e o Simplify3D.



SEGURANÇA

- O cabo de alimentação deve ser ligado a uma tomada com ligação à terra.
- A fonte de alimentação deve ser instalada perto do equipamento e a tomada deve ser de fácil acesso.
- Utilize apenas o cabo de alimentação fornecido pelo fabricante. A utilização de cabos de alimentação não autorizados pode causar perigo e violar a autorização do produto, bem como a garantia.
- A ficha do cabo de alimentação é considerada um dispositivo de desligamento. Uma vez desligada da tomada, considera-se que o produto está desligado da alimentação.
- Não utilize o dispositivo num ambiente em que a temperatura esteja demasiado alta ou demasiado baixa. Nunca exponha o dispositivo a luz solar forte ou a ambientes húmidos.
- O intervalo de temperaturas adequado para o produto e respetivos acessórios é 15 °C a 35 °C.
- É recomendado que instale o dispositivo num ambiente com uma temperatura entre 15 °C e 25 °C.
- Durante o fornecimento, coloque o dispositivo num ambiente com uma temperatura ambiente normal e uma ventilação adequada.
- Este equipamento não é adequado para utilização em locais onde possam existir crianças. Este equipamento não se destina a ser utilizado por crianças.
-  Peças móveis. Mantenha-se afastado das peças móveis.
-  ATENÇÃO Peças quentes. Não tocar.
- Não utilize o produto de forma diferente da descrita neste documento para evitar lesões ou danos materiais.
- O utilizador deve respeitar as leis e regulamentos dos países e regiões onde o equipamento se encontra localizado (é utilizado), respeitar a ética profissional, prestar atenção às obrigações de segurança e proibir estritamente a utilização dos nossos produtos ou equipamentos para qualquer fim ilegal. Em nenhuma circunstância será a nossa empresa responsável por qualquer responsabilidade legal dos infratores.

AVISO

Aviso (Europa e Reino Unido)

 Este produto cumpre as normas de interferências de rádio da Comunidade Europeia.

Declaração de Conformidade

Por este meio, a Anker Innovations Limited declara que este dispositivo está em conformidade com os requisitos essenciais e outras disposições relevantes da Diretiva 2014/53/UE. Para consultar a declaração de conformidade, visite o site: <https://ankermake.com>.



Este produto cumpre as normas de interferências de rádio do Reino Unido

Declaração de Conformidade

Por este meio, a Anker Innovations Limited declara que este dispositivo está em conformidade com os Regulamentos de Equipamento de Rádio de 2017 (SI 2017/1206). O texto completo da declaração de conformidade do Reino Unido está disponível no seguinte endereço de Internet: <https://ankermake.com>.

Informações sobre exposição a RF:

O nível de Exposição Máxima Admissível (MPE - Maximum Permissible Exposure) foi calculado com base numa distância de d=20 cm entre o dispositivo e o corpo humano. Para manter a conformidade com os requisitos de exposição a RF, utilize o produto mantendo uma distância de 20 cm entre o dispositivo e o corpo humano.

As bandas de frequência e a potência são as indicadas abaixo:

Função	Bandas	Frequência de funcionamento	Pot. máx.
Wi-Fi	2,4 GHz	2412-2472 MHz	EIRP 19,10 dBm
Bluetooth	2,4 GHz	2402-2480 MHz	EIRP 8,0 dBm

O importador seguinte é a entidade responsável (contacte para questões no âmbito da UE):
Anker Innovations Deutschland GmbH | Georg-Mueller-Strasse 3, 80807 Munique, Alemanha

O importador seguinte é a entidade responsável (contacte para questões no âmbito do Reino Unido):
Anker Technology (UK) Limited | GNR8, 49 Clarendon Road, Watford, Hertfordshire, WD17 1HP, United Kingdom



O produto foi concebido e fabricado com materiais e componentes de alta qualidade, que podem ser reciclados e reutilizados.



Este símbolo significa que o produto não deve ser eliminado como lixo doméstico e deve ser entregue numa instalação de recolha apropriada para reciclagem. A eliminação e a reciclagem corretas ajudam a proteger os recursos naturais, a saúde humana e o ambiente. Para obter mais informações sobre a eliminação e a reciclagem deste produto, contacte o seu município, os serviços de eliminação ou o local de compra do produto.

163 PT

各部分の名称

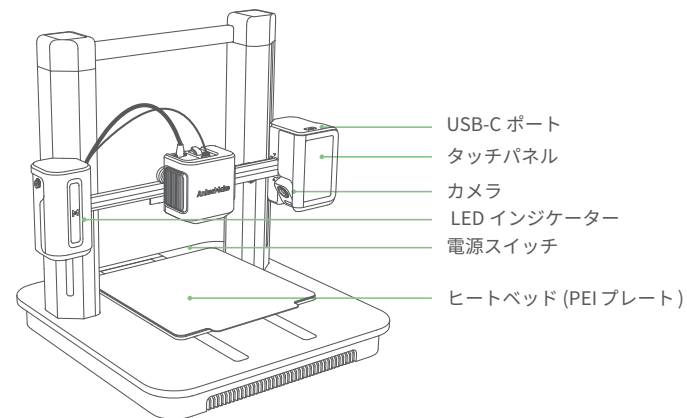

LEDインジケータ*	状態
オレンジ色でゆっくり点滅	加熱中
緑色でゆっくり点滅	プリント中
赤色で点滅	アラームが作動中

* その他の LED インジケータの状態については、Anker Japan 公式サイト (www.ankerjapan.com) の製品ページをご覧ください。
製品名: AnkerMake M5 型番: V8111

JP 164

組み立て方法

同梱品

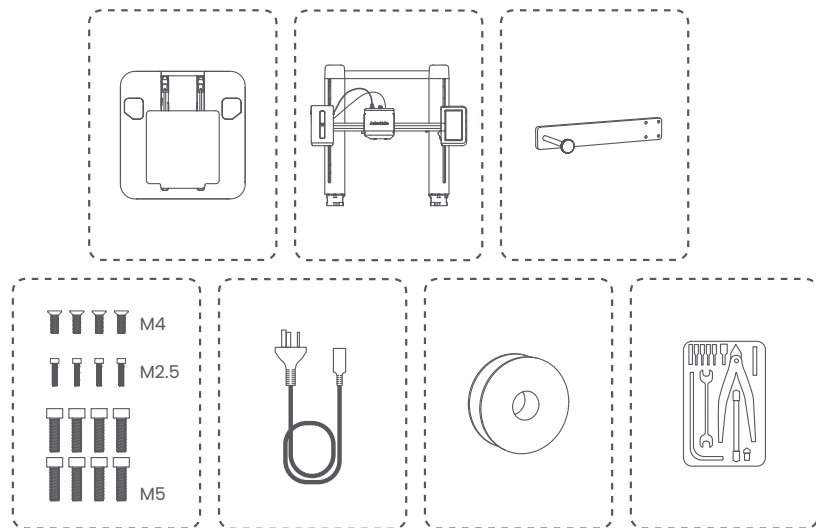

*同梱のコンセントは
日本仕様です。

手順 1 フレームの取り付け

1. パッケージを開け、上部に敷いている梱包材を机などの平らな場所に置きます。

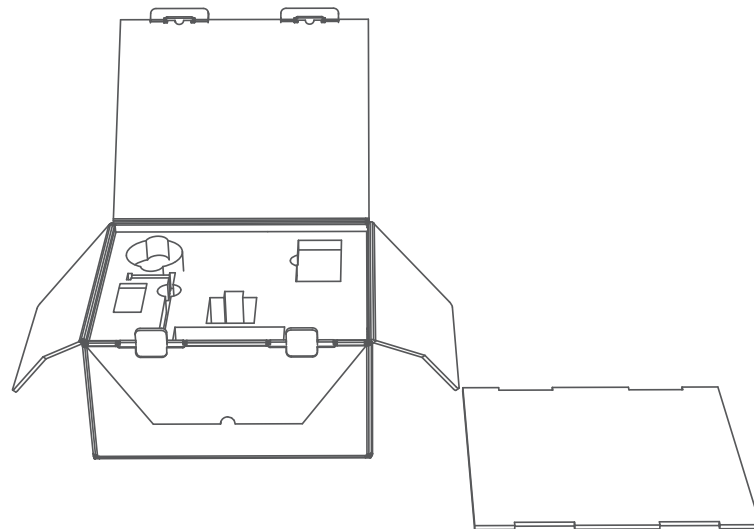

2. アクセサリを梱包材からすべて取り出し、1 で取り出した梱包材の上部に、イラストの通りに置きます。

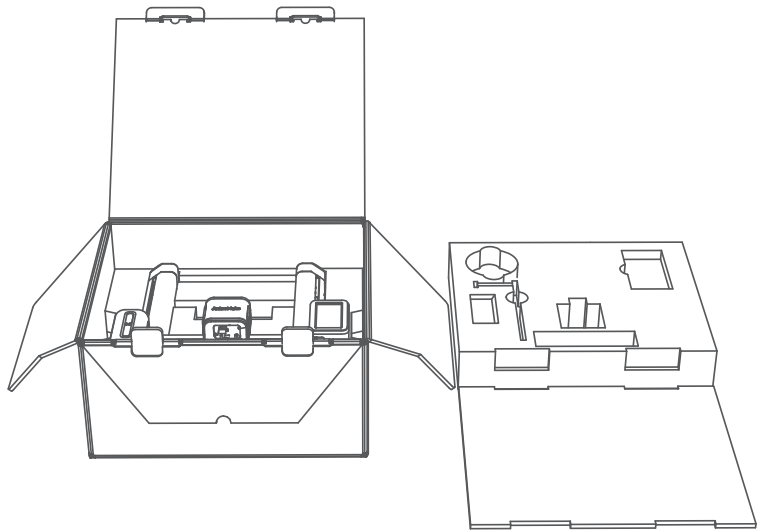

3. 本体 (フレーム部分) を梱包材ごとパッケージから取り出し、2 で床に置いた梱包材の上に置きます。

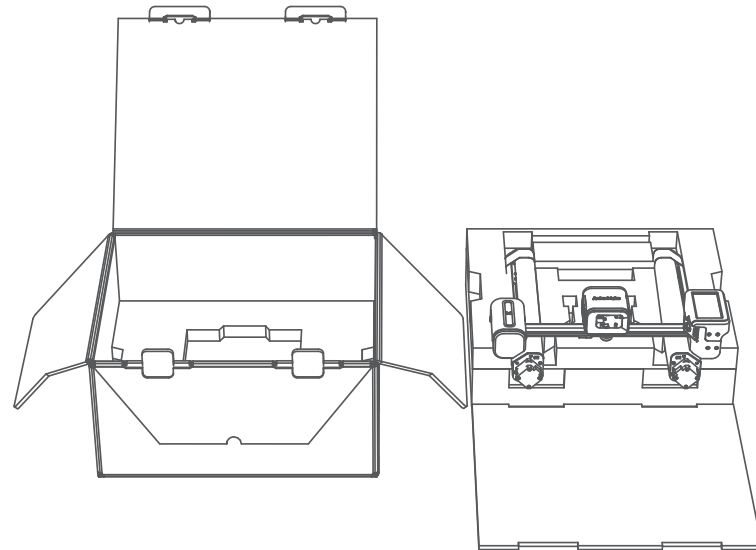

4. フレームを一度梱包材から取り出し、イラストのように少し下にずらして梱包材に置き直します。

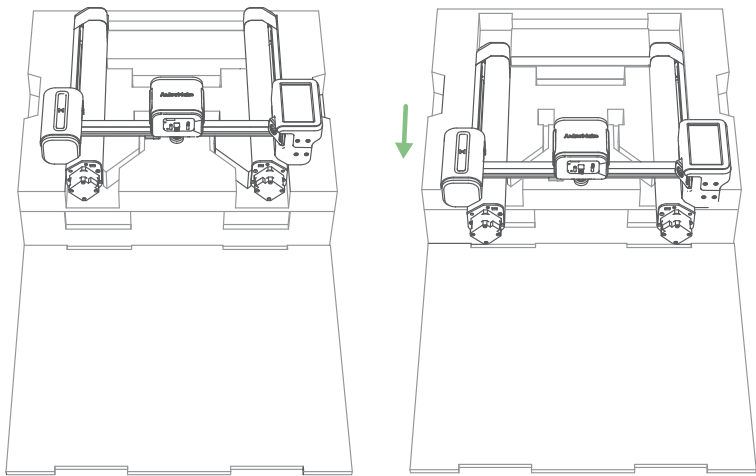

5. プラットフォームをパッケージから取り出し、底面のカバーを取り外します。

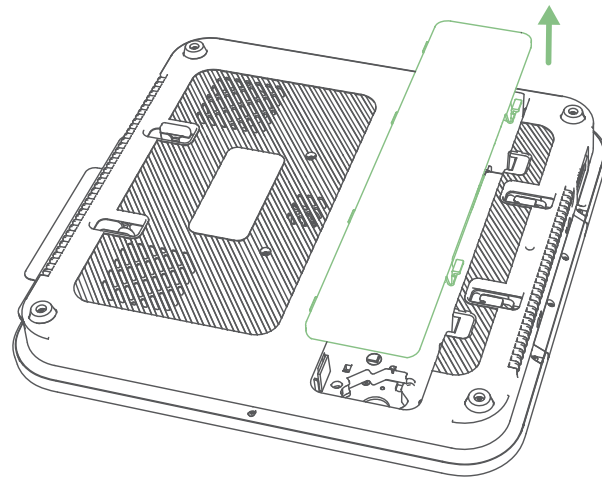

6. プラットフォームの穴にフレームの下部を通して、プラットフォームをフレームに取り付けます (ケーブルも一緒に穴に通してください)。

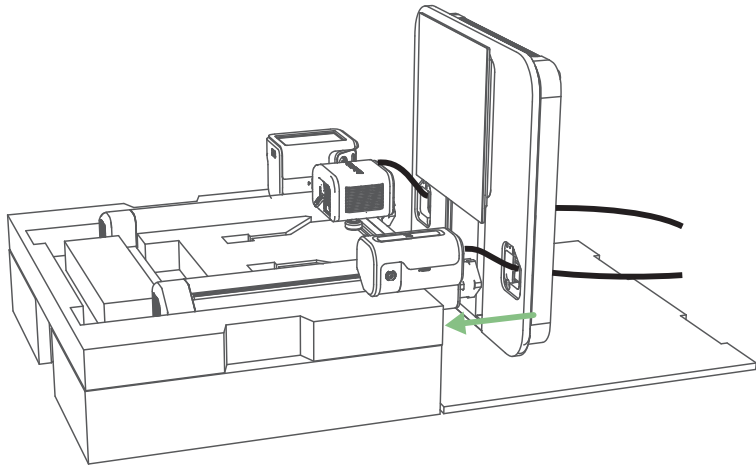

7. 同梱のネジ (M5) でイラストの箇所を固定します。

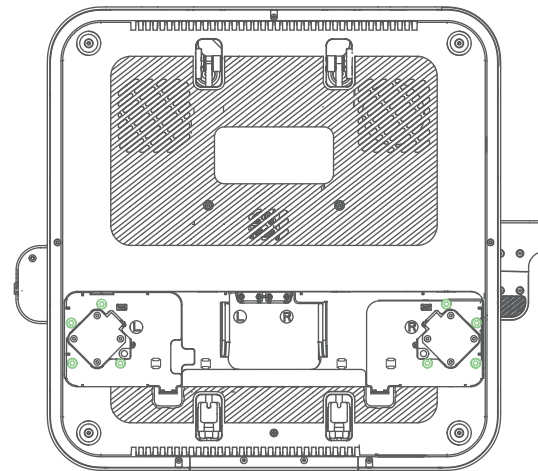

◎ M5

手順 2 配線

1. ワイヤーを、イラストの通りモーターに接続します。

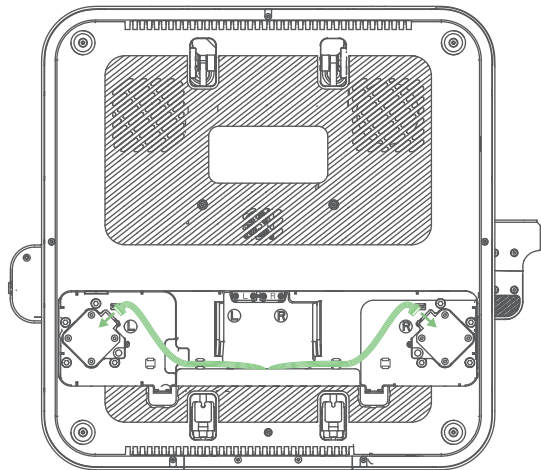

2. 手順 1 の 6 でプラットフォームに通した USB-C ケーブルを、L と R が合うように接続し、同梱のネジ (M2.5) で固定します。

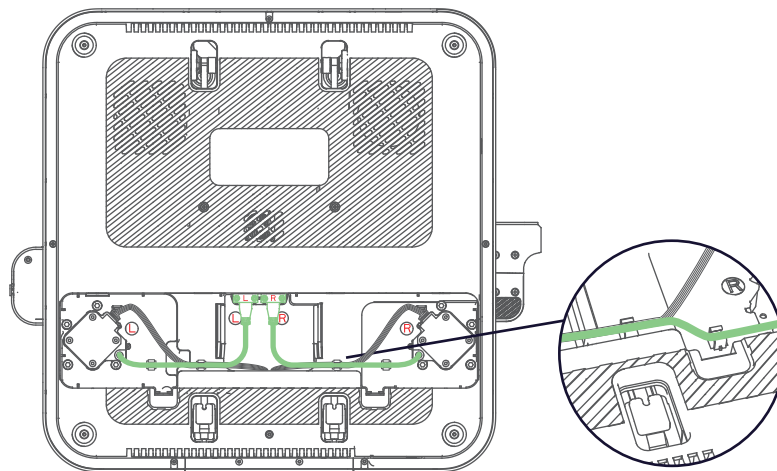

◎ M2.5

3. 底面のカバーをプラットフォームに取り付けます。

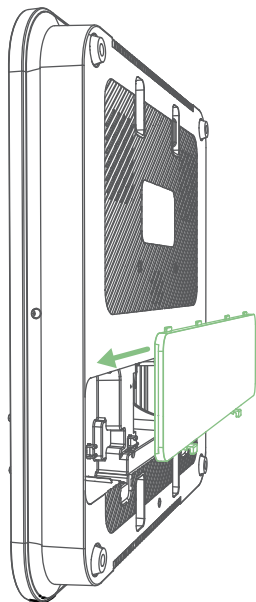

手順3 フィラメントホルダーの取り付け

フィラメントホルダーを、同梱のネジ (M4) でフレームに縦向きもしくは横向きに取り付けます。

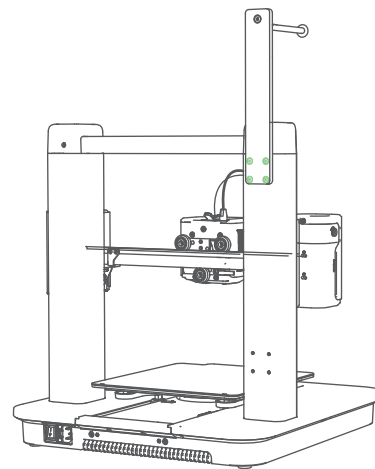

オプション1：縦向き

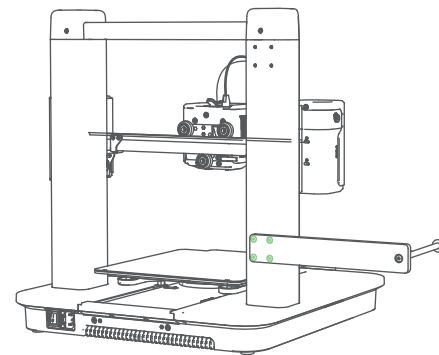

オプション2：横向き
(上下どちらにも取り付けられます)

手順 4 電源への接続

1. 電源コードをプラットフォームの背面に接続し、電源スイッチをオンにします。

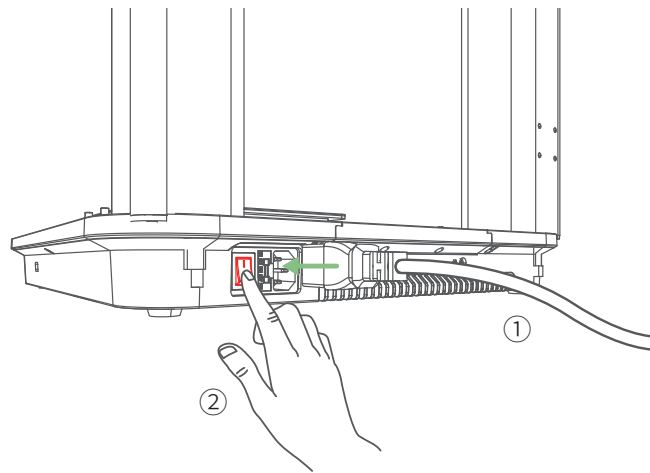

2. タッチパネルの指示に従って、初期設定を完了します。

システムのセットアップ

1. App Store もしくは Google Play から AnkerMake アプリをダウンロードし、アカウント登録をします。



2. 画面の指示に従って機器を追加し、Wi-Fi (2.4G) に接続します。

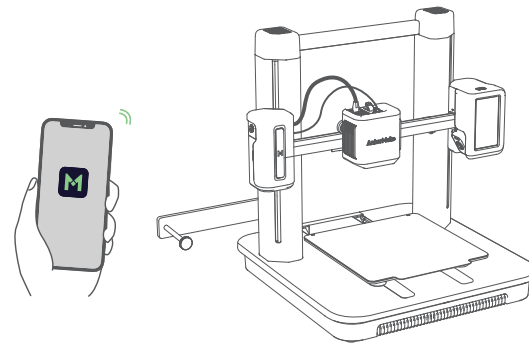

ヒートベッドのレベリング

タッチパネルで、[コントロール]>[レベリング]の順に進み、ヒートベッドのレベリングを実行します。

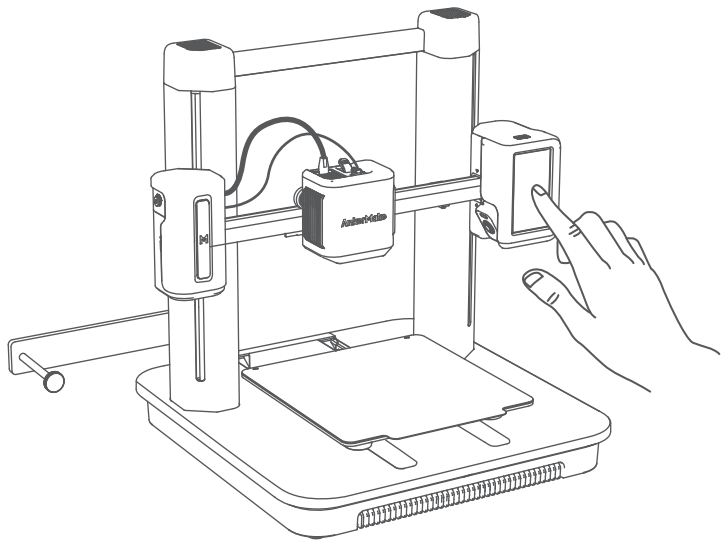

フィラメントのセット

1. フィラメントを、フィラメントホルダーに設置します。

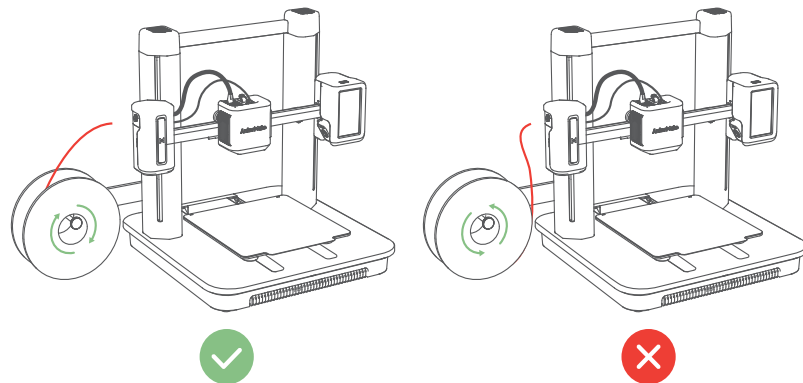

2. フィラメントの先端を45°の角度でカットします。

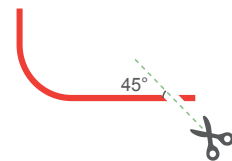

3. フィラメントをイラストの穴に挿入し、エクストルーダーに届くまで押し込みます。次に、エクストルーダーの上部にあるレバーを押しながらフィラメントの挿入を続けます。抵抗を感じたところで、挿入するのを止めます。

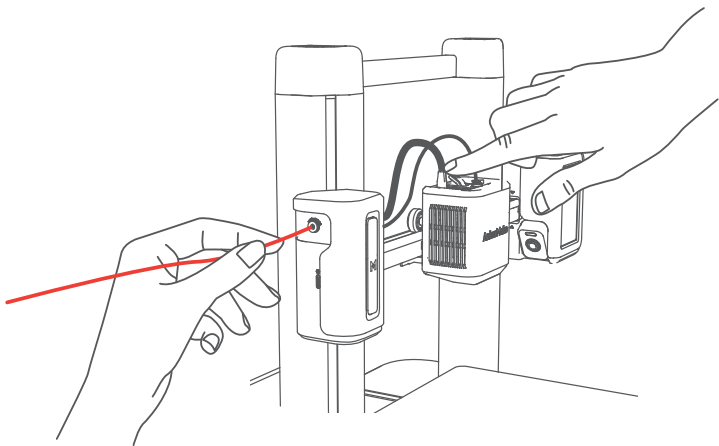

4. タッチパネルで、[コントロール]>[押し出し]>[ロード]をタップします。加熱が完了し、ノズルからフィラメントが流れ出たら、[停止]をタップします。

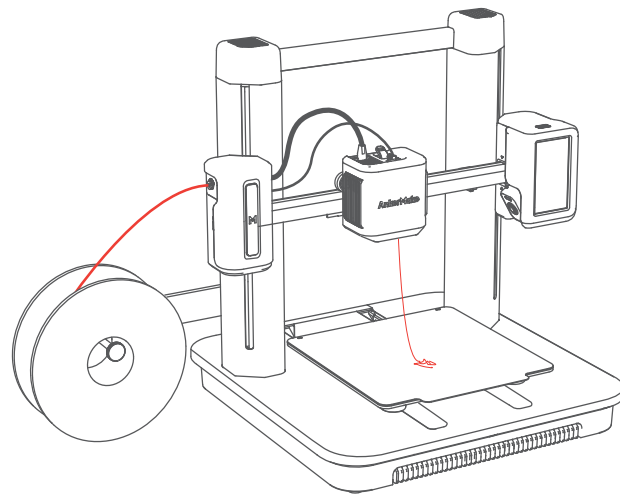

AnkerMake スライサーのインストール

より快適にご利用いただくには、AnkerMake スライサーを、Anker Japan 公式サイト (www.ankerjapan.com) の製品ページからお使いの PC へインストールしてください。

💡 他社製のスライサーソフトウェアをご利用の場合、AI 認識機能はご利用いただけません。

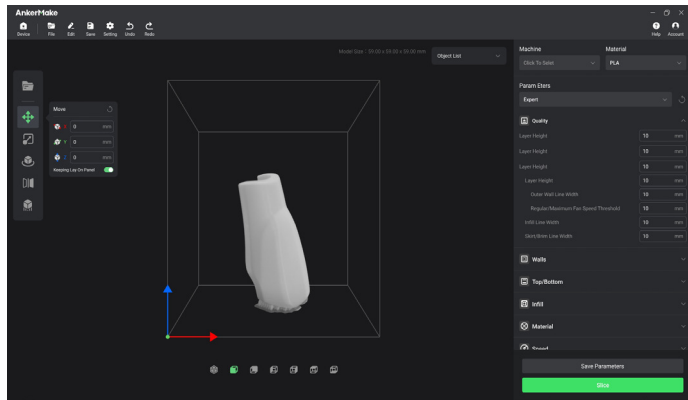

安全に関する注意事項

- 電源コードは、接地接続 (アース) されたコンセントに接続してください。
- 本製品はコンセントの近くに設置し、手の届きやすい状態にしてください。
- 付属の電源コードのみを使用してください。付属の電源コード以外のコードを使用した場合、怪我や本製品の損傷の恐れや、保証の対象外となる可能性があります。また、付属の電源コードは本製品以外には使用しないでください。
- プラグをコンセントから抜くと、本製品の電源はオフになります。
- 極端に高温または低温の環境で本製品を使用しないでください。また、直射日光や湿気にさらさないでください。
- 本製品およびアクセサリの動作温度は 15°C~35°C ですが、15°C~25°C の環境でご使用されることをお勧めします。
- 風通しの良い場所でご使用ください。
- お子様の近くで使用しないでください。本製品は、お子様が使用することを想定していません。
- ⚠️ 可動式パーツ：このマークは、当該部が可動式であることを示しています。動作中は、身体をこのパーツに近づけないでください。
- ⚠️ 高温注意：このマークは、当該部が高温になることを示しています。動作中は、このパーツに手を触れないでください。
- けがや物的損害を避けるために、本説明書に記載された以外の方法で本製品を使用しないでください。
- 本製品の使用者は、本製品が使用される国・地域の法令を遵守し、職業倫理を守り、安全義務に留意するものとし、本製品の違法な目的での使用を固く禁じられています。当社は、いかなる場合においても、違反者の法的責任について一切の責任を負いません。



本製品は、リサイクルおよび再利用が可能な高品質の素材および部品を使用して設計・製造されています。



本製品を廃棄する際は、お住まいの自治体のルールに従ってください。

商標



Bluetooth® のワードマークとロゴは、Bluetooth SIG, Inc. が所有する登録商標です。Anker Innovations Limited はライセンスに基づき、これらのマークの使用を許可されています。その他の商標および商標名は、それぞれの所有者に帰属します。

한눈에 보기

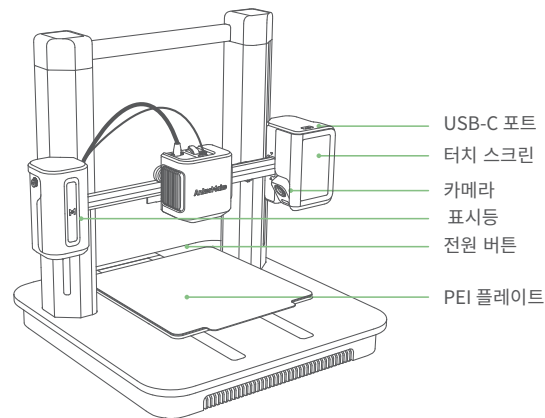

표시등 *	설명
주황색으로 천천히 깜박임	예열 중
녹색등 점등 반복	인쇄 중
적색 등 깜박임	알람 작동 중

* 표시등 상태에 대한 자세한 내용은 <https://www.ankermake.com> 을 참조하세요.
제품명 : AnkerMake M5 모델 : V8111

프린터 조립하기

준비 사항

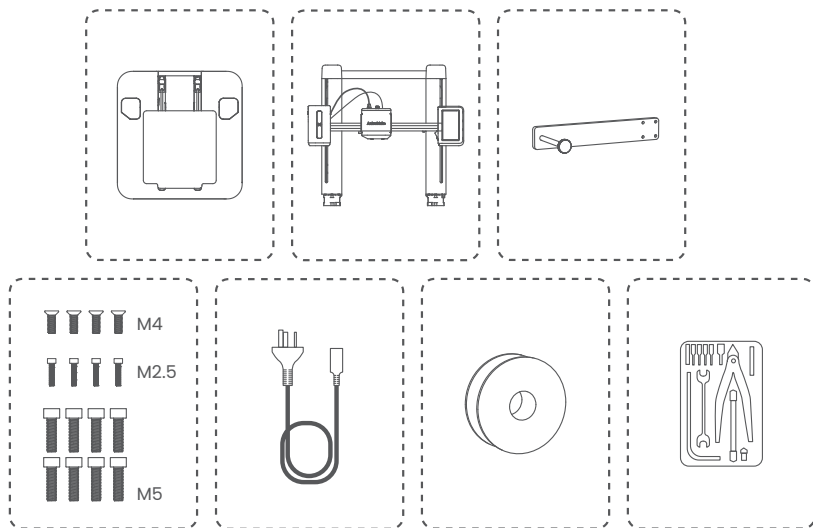

1 단계 . 갠트리 프레임 설치하기

1. 상자를 연 다음, 커버를 바닥에 놓습니다.

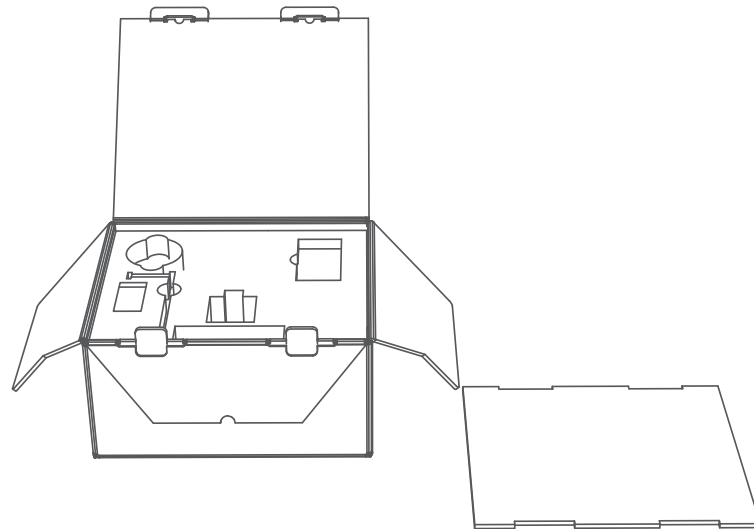

2. 포장된 모든 액세서리를 꺼낸 후, 보호 스티로폼을 지지 용도로 사용할 수 있도록 바닥에 놓습니다.

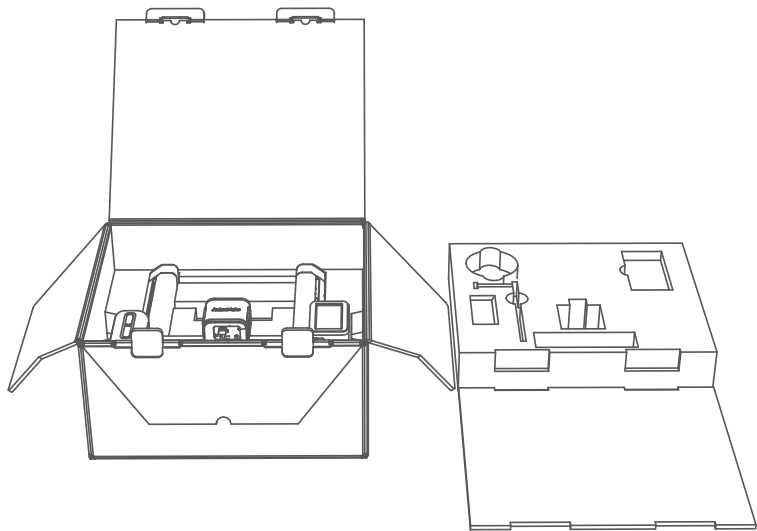

3. 갠트리 프레임을 보호 폼과 함께 꺼내 지지용 폼 위에 놓습니다.

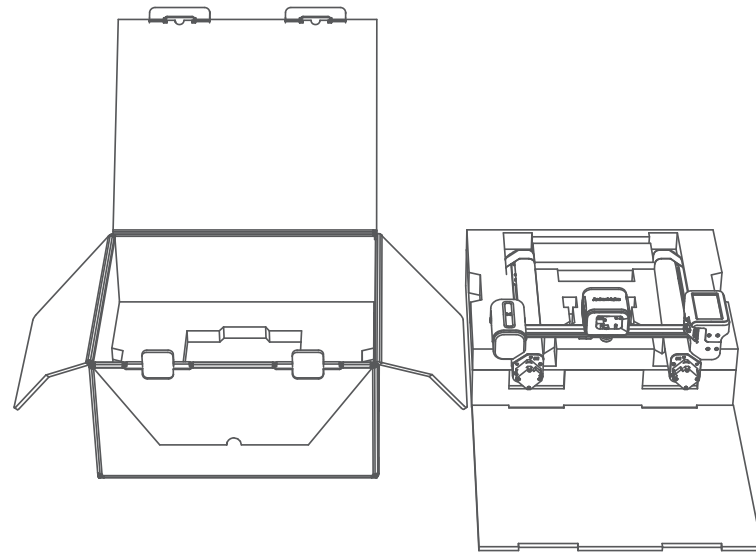

4. 패키지에서 갠트리 프레임을 꺼낸 다음 ,아래 그림과 같이 놓습니다 .

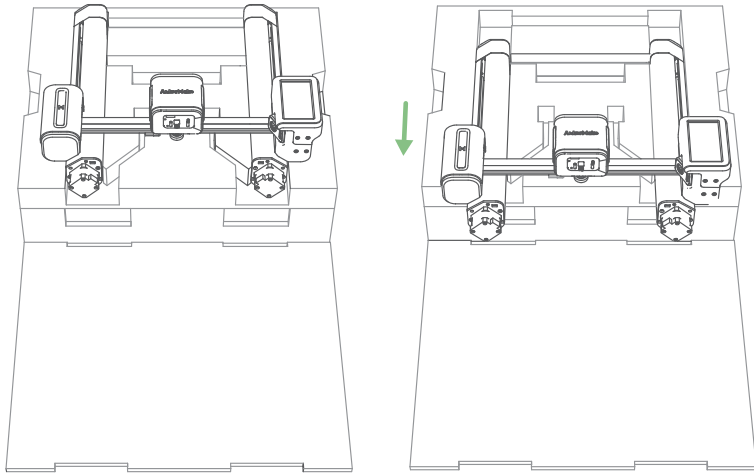

5. 플랫폼에서 하단 커버를 분리합니다 .

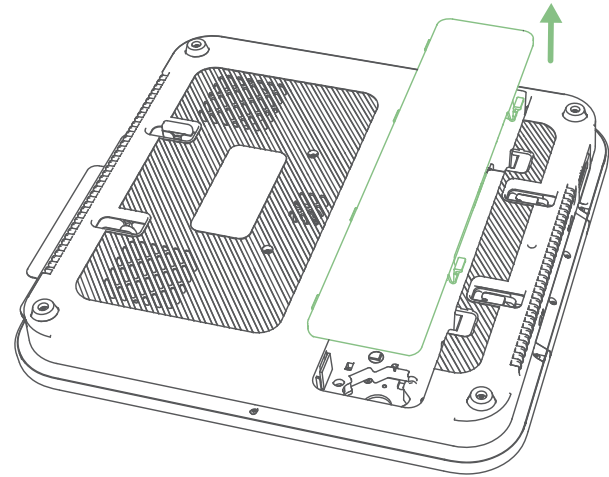

6. 플랫폼을 그림과 같이 구멍에 맞춰 장착합니다.

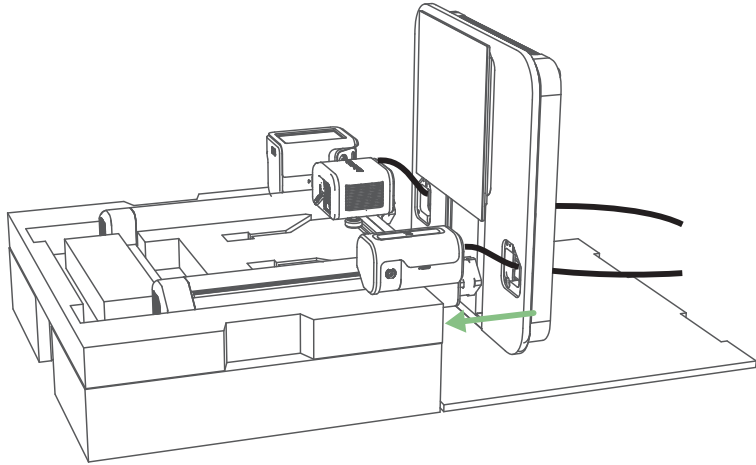

7. 나사를 조여 플랫폼에 고정시킵니다.

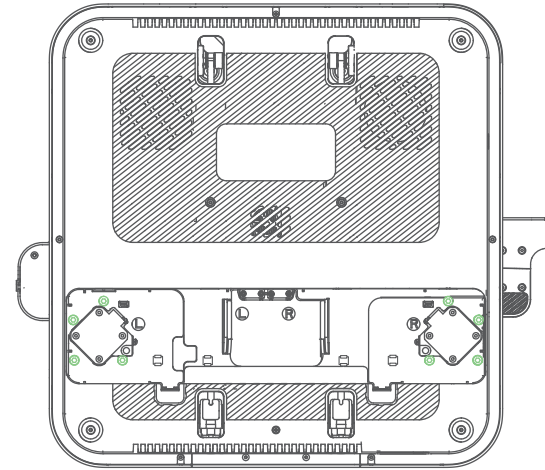

◎ M5

2 단계 . 케이블 연결하기

1. 모터 와이어를 연결합니다.

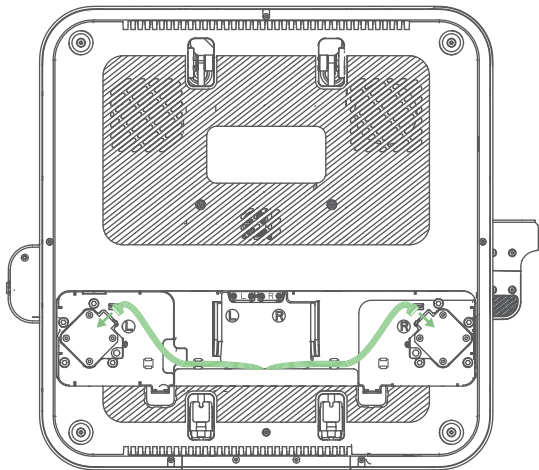

2.USB-C 케이블을 연결한 다음 , 나사로 고정합니다.

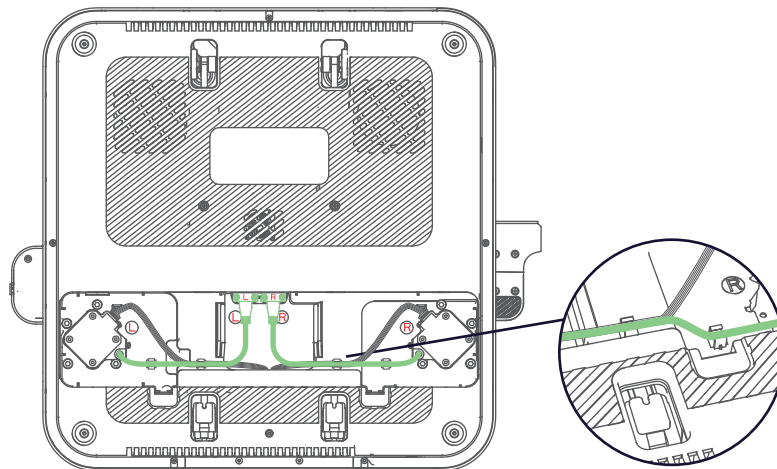

⊙ M2.5

3. 하단 커버를 플랫폼 위에 다시 놓습니다.

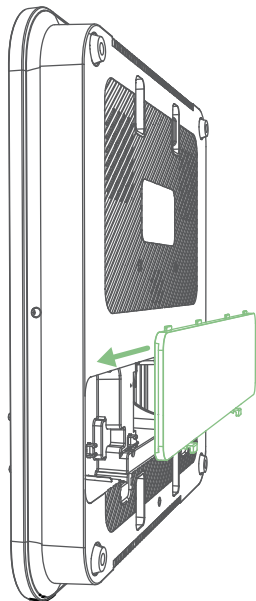

3 단계 . 필라멘트 홀더 설치하기

필라멘트 홀더를 나사로 고정합니다 .

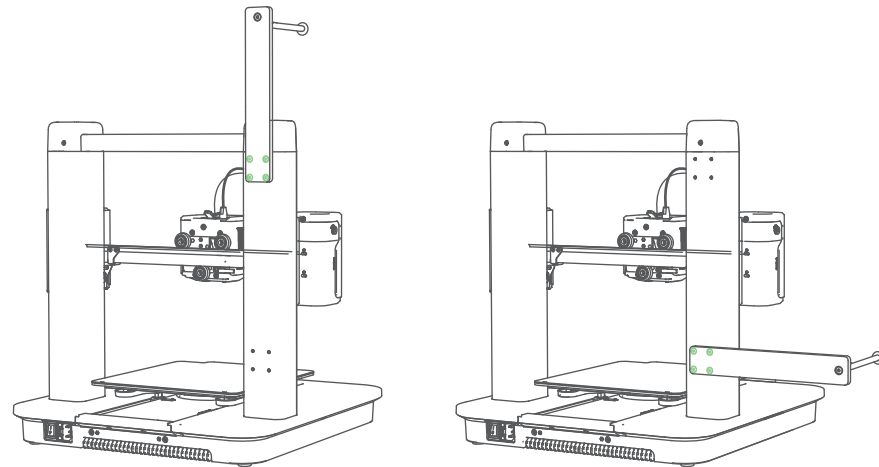

⊙ M4

4 단계 . 전원 연결하기

1. 전원 케이블을 사용하여 프린터를 전원 콘센트에 연결한 다음, 프린터 전원을 켭니다.

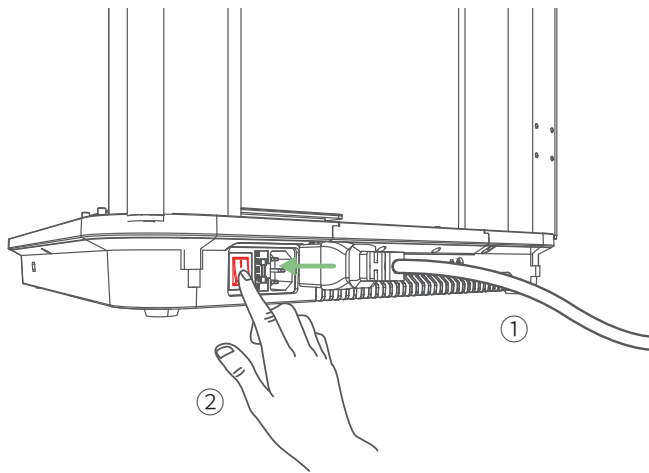

2. 터치 스크린에 안내되는 지시에 따라 초기 설정을 완료합니다.

시스템 설정하기

1. AnkerMake 앱을 다운로드하여 설치한 다음, 계정을 새로 만듭니다.



2. 화면에 안내되는 지침에 따라 프린터를 기기 목록에 추가하고 Wi-Fi에 연결합니다.

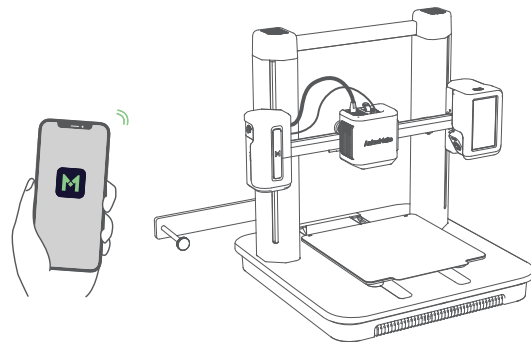

히트 베드 수평 맞추기

터치 스크린에서 **Control > Auto-Level** 로 이동하여 히트 베드의 수평을 맞춥니다.

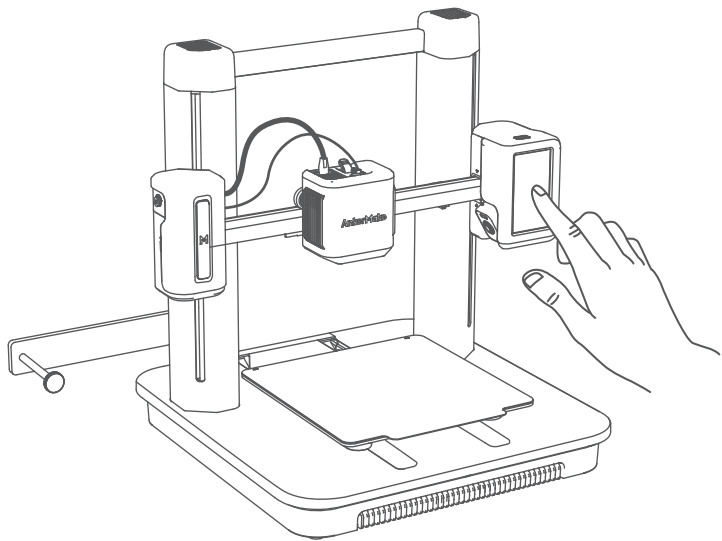

필라멘트 로드하기

1. 필라멘트를 홀더에 놓습니다.

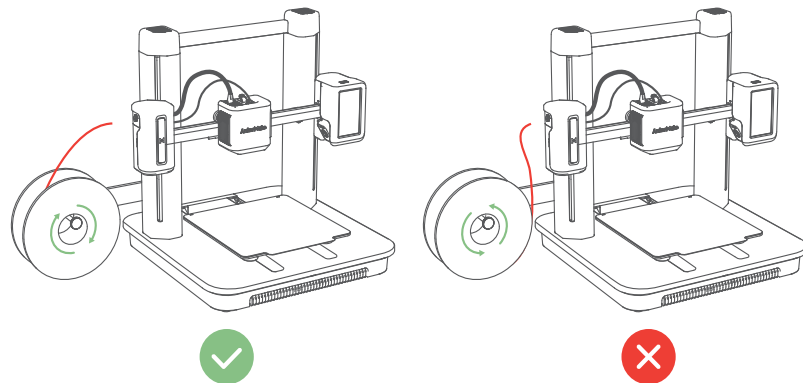

2. 필라멘트 끝을 45° 각도로 자릅니다.

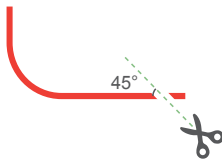

3. 익스트루더에 닿을 때까지 필라멘트를 삽입합니다. 익스트루더 상단에 있는 물리 버튼을 누른 상태로 필라멘트를 계속해서 삽입합니다. 필라멘트가 끝까지 닿은 느낌이 나면 삽입을 중지하십시오.

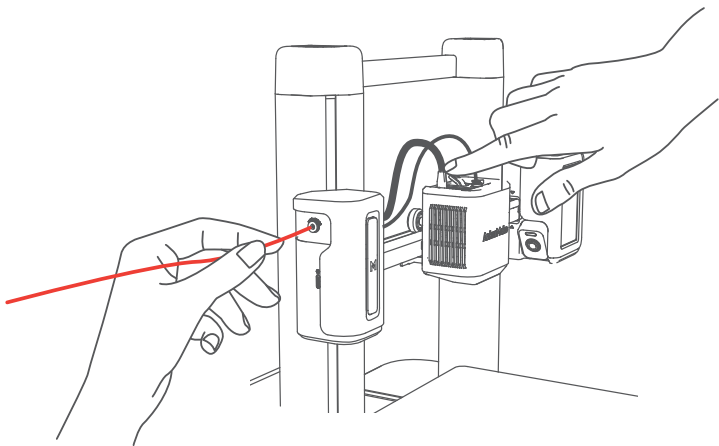

4. 터치 스크린에서 **Control > Load > Extrude** 를 탭합니다. 노즐에서 필라멘트가 흘러나올 때까지 기다린 다음 **Stop** 을 탭합니다.

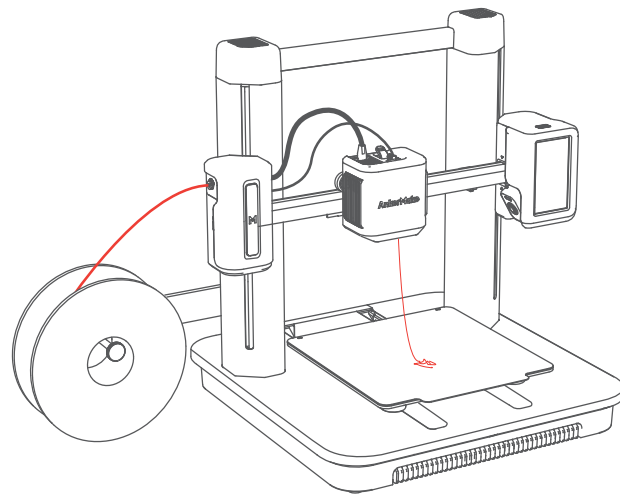

AnkerMake Slicer 설치하기

최적의 프린트 설정을 위해 ankermake.com/software 에서 AnkerMake Slicer 를 컴퓨터에 다운로드 및 설치하십시오.

💡 Cura, Simplify3D 와 같은 다른 3D 슬라이서 소프트웨어를 사용하여 프린터를 작동하는 경우에는 AI 인식 기능을 사용할 수 없습니다.

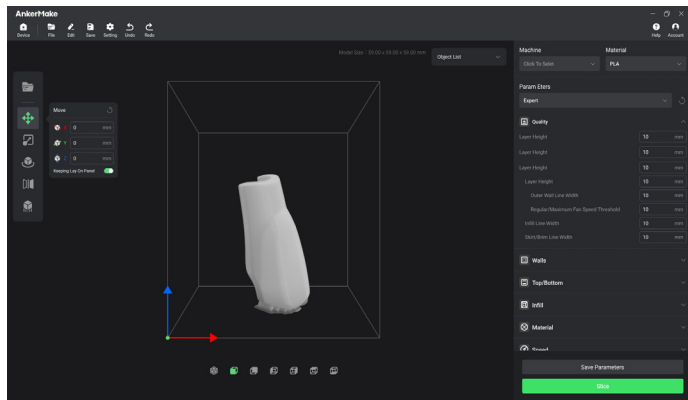

안전사항

- 전원 코드는 접지 연결된 소켓 콘센트에 연결해야 합니다.
- 전원 공급 장치는 기기 근처에 설치해야 하며, 콘센트에 가까이 있어야 합니다.
- 제조업체에서 제공한 전원 코드만 사용하십시오. 승인되지 않은 전원 코드를 사용하면 위험이 발생할 수 있으며 제품의 승인 및 보증 관련 조항을 위반할 수 있습니다.
- 전원 코드의 플러그는 분리 장치로 간주됩니다. 플러그가 뽑히면 제품이 전원에서 분리된 것으로 간주됩니다.
- 온도가 너무 높거나 너무 낮은 환경에서 이 기기를 사용하지 마십시오. 강한 햇빛이나 습한 환경에 기기를 노출시키지 마십시오.
- 이 제품과 액세스리의 적정 보관 온도는 15° C~35° C 입니다.
- 온도 범위가 15° C~25° C 인 환경에서 기기를 사용하는 것이 좋습니다.
- 정상 범위의 실내 온도이고 통풍이 잘 되는 환경에 기기를 두고 사용하십시오.
- 이 장비는 어린이가 있는 장소에서 사용하기에 적합하지 않습니다. 이 장비는 어린이가 사용해서는 안 됩니다.



움직이는 부품. 움직이는 부품 가까이 있지 마십시오.



주의 뜨거운 부품. 만지지 마십시오.

- 부상 및 재산 피해의 방지를 위해 안내된 방법이 아닌 다른 방법으로 제품을 사용하지 마십시오.
- 사용자는 장비가 위치 (사용) 되는 해당 국가 및 지역의 법규를 준수하고, 직업윤리를 준수하며, 안전 의무를 준수해야 합니다. 또한 당사 제품 또는 장비를 불법적인 용도로 사용하는 것을 엄격히 금지해야 합니다. 당사는 어떠한 경우에도 권고사항 위반에 관한 법적 책임을 지지 않습니다.



이 제품은 한국의 무선 간섭 요구 사항을 준수합니다.



이 기호는 제품을 가장 쓰레기로 폐기해서는 안 되며 재활용을 위해 적절한 수거 시설로 보내야 함을 의미합니다.



적절한 폐기 및 재활용은 천연 자원, 사람의 건강 및 환경을 보호하는 데 도움이 됩니다. 적절한 폐기 및 재활용은 천연 자원, 인간의 건강 및 환경을 보호하는 데 도움이 됩니다. 이 제품의 폐기 및 재활용에 대한 자세한 내용은 지역 자치 단체, 폐기 서비스 또는 제품을 구입한 판매점에 문의하십시오.

نظرة سريعة

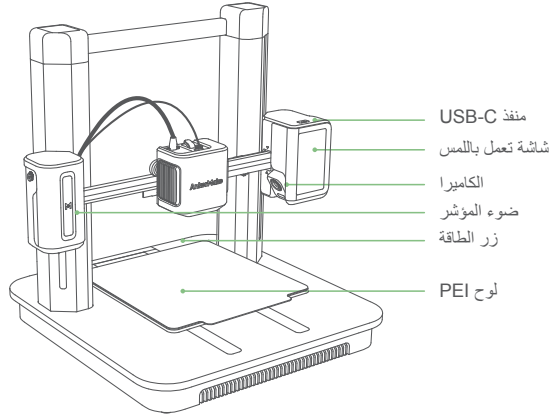

الوصف	ضوء المؤشر*
زيادة درجة الحرارة	وميض بطيء باللون البرتقالي
جار الطبع	وميض خافت متكرر باللون الأخضر
انطلاق جرس الانذار	وميض باللون الأحمر

* لمعرفة مزيد من حالة ضوء المؤشر، قم بزيارة <https://www.ankermake.com>
اسم المنتج: AnkerMake M5 الطراز: V8111

تجميع الطابعة

ما تحتاج إليه

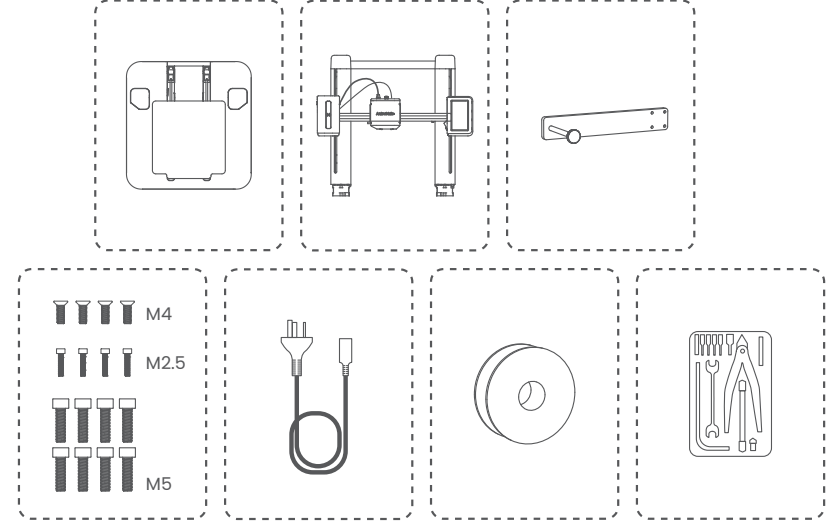

الخطوة 1. تركيب إطار جسر الرافعة

1. افتح الصندوق، ثم ضع الغطاء الفوم على الأرض.

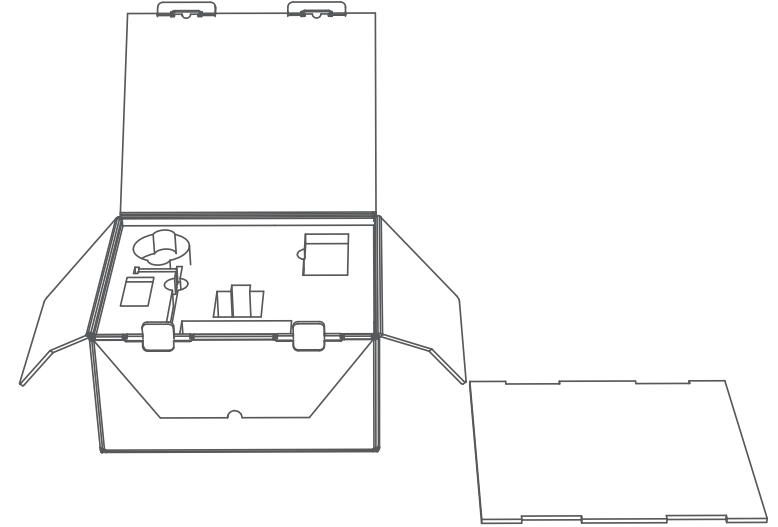

AR 210

2. أخرج جميع الملحقات الموجودة من الفوم، ثم ضع فوم الحماية على الأرض كدعامة.

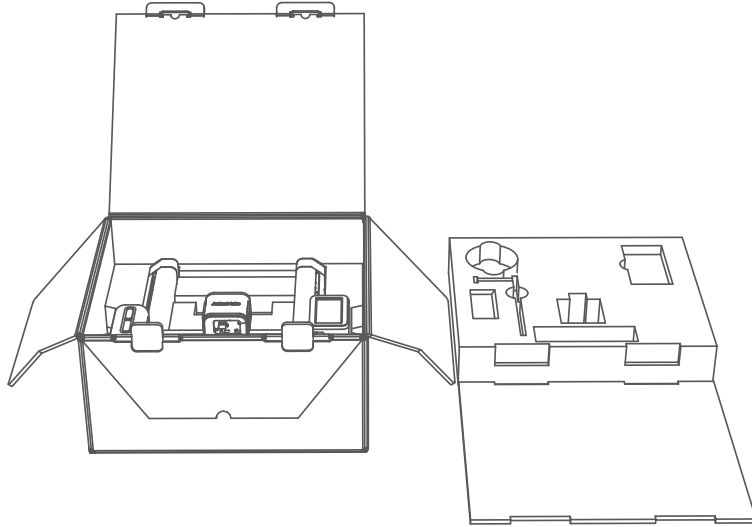

209 AR

3. أخرج إطار جسر الرافعة بفوم الحماية الخاص به وضعه على الفوم الدعامة.

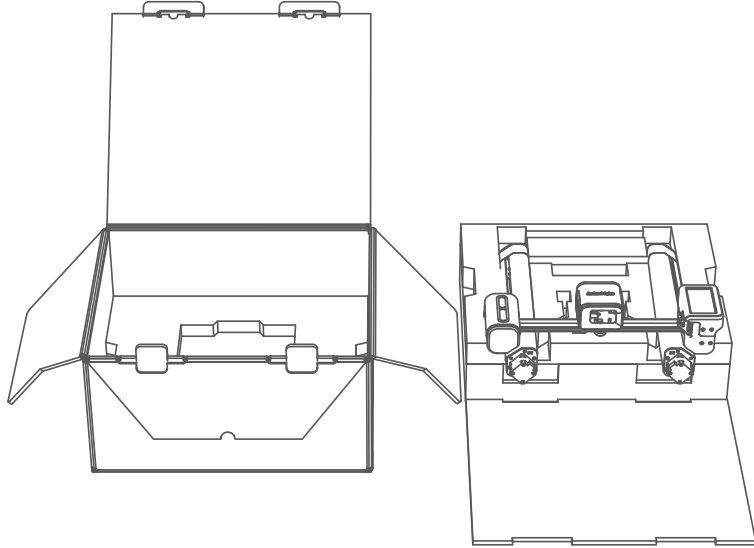

4. أخرج إطار جسر الرافعة من فوم التغليف، ثم أرجعه للخلف كما هو موضح أدناه.

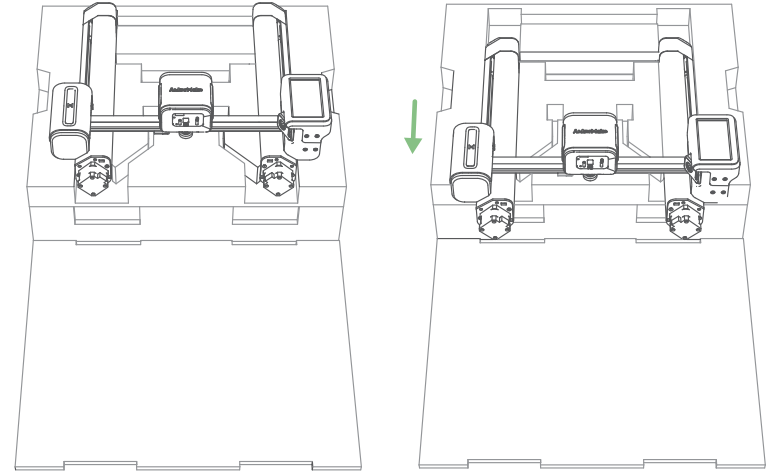

5. افصل الغطاء السفلي عن المنصة.

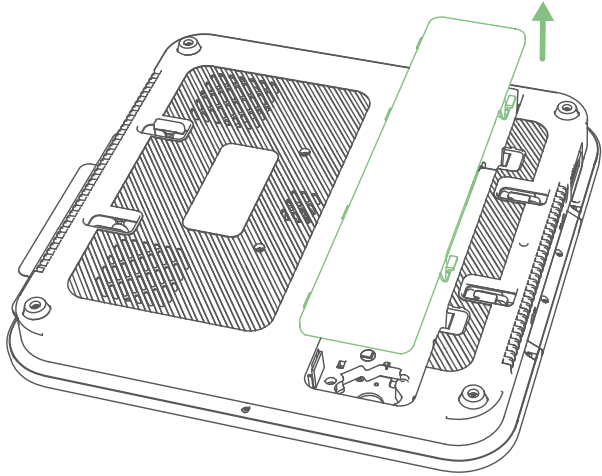

213 AR

6. ركب المنصة في الفتحات.

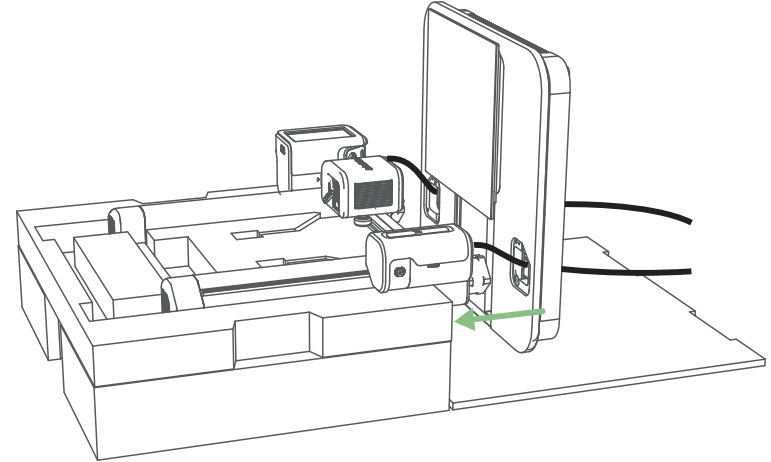

AR 214

الخطوة 2. الأسلاك

1. وصل أسلاك المحرك.

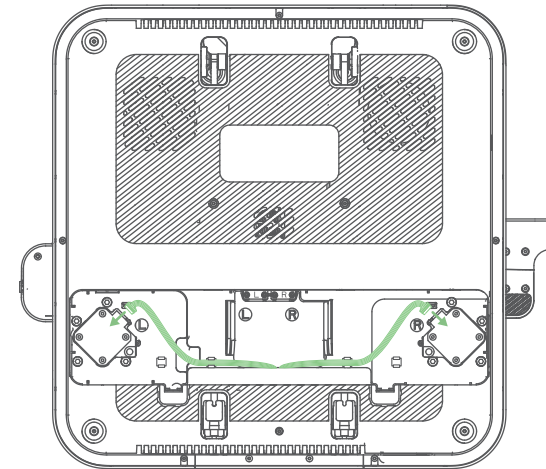

7. اربط المسامير في المنصة.

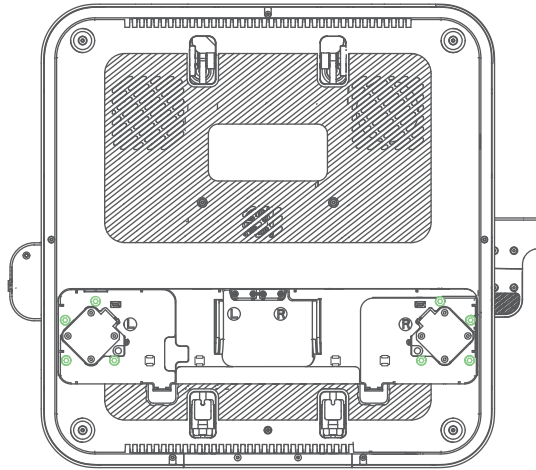

⊙ M5

2. وصل وثبت كابلات USB-C باستخدام البراغي.

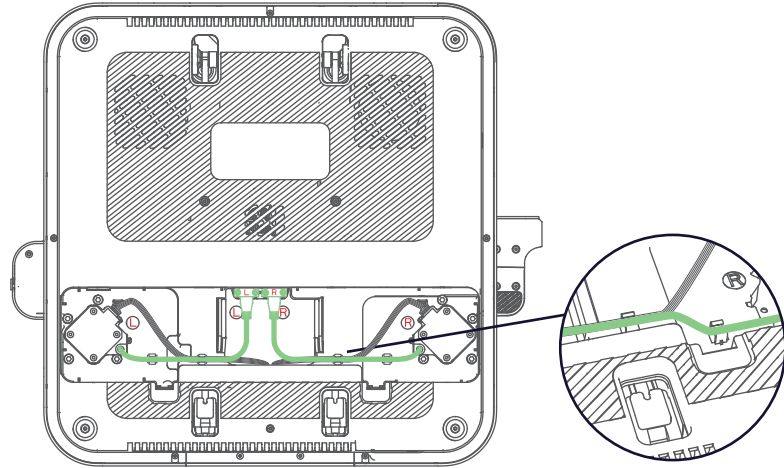

⊙ M2.5

217 AR

3. ضع الغطاء السفلي مرة أخرى على المنصة.

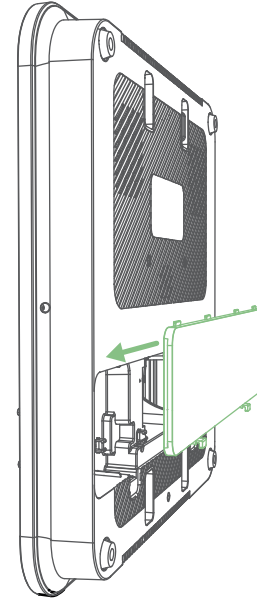

AR 218

الخطوة 3. تركيب حامل الخيوط

تثبت حامل الخيوط باستخدام المسامير.

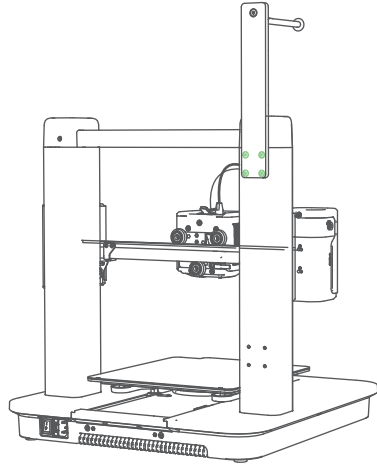

الخيار 1

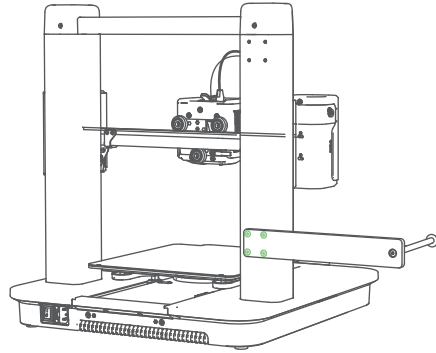

الخيار 2

M4

الخطوة 4. التوصيل بالطاقة

1. وصل الطابعة بمأخذ الطاقة باستخدام كابل الطاقة، ثم شغّلها.

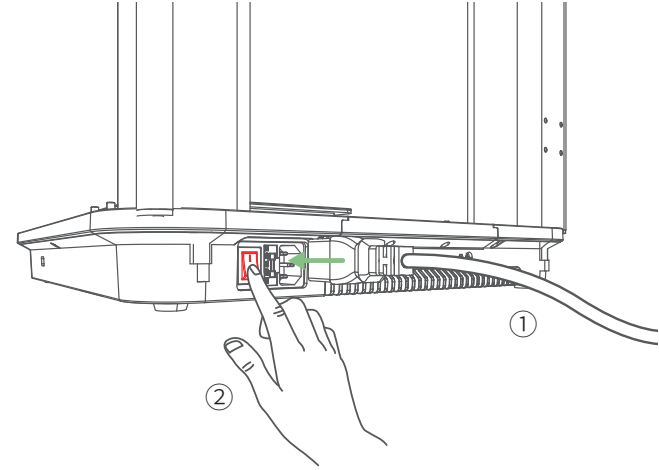

2. اتبع التعليمات التي تظهر على الشاشة التي تعمل باللمس لإكمال الإعداد الأولي.

إعداد النظام

1. نزل تطبيق AnkerMake وثبته، ثم سجّل للحصول على حساب.



2. اتبع التعليمات التي تظهر على الشاشة لإضافة الطابعة إلى قائمة أجهزتك وتوصيلها بشبكة Wi-Fi.

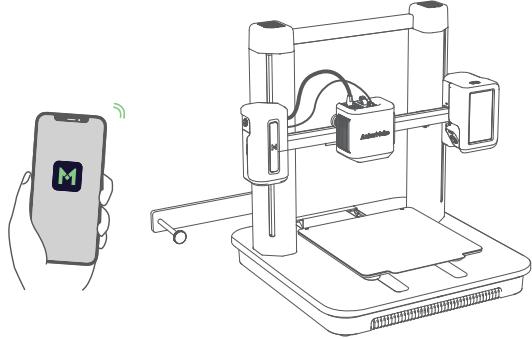

تحديد مستوى سخونة السطح

على الشاشة التي تعمل باللمس، انتقل إلى **Control > Auto-Level** (تحديد تلقائي) لتحديد مستوى سخونة السطح.

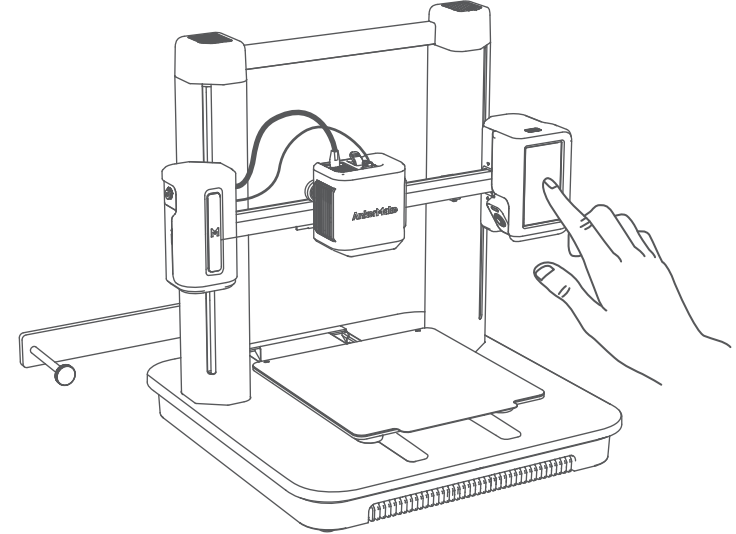

تحميل الخيط

1. ضع الخيط على الحامل.

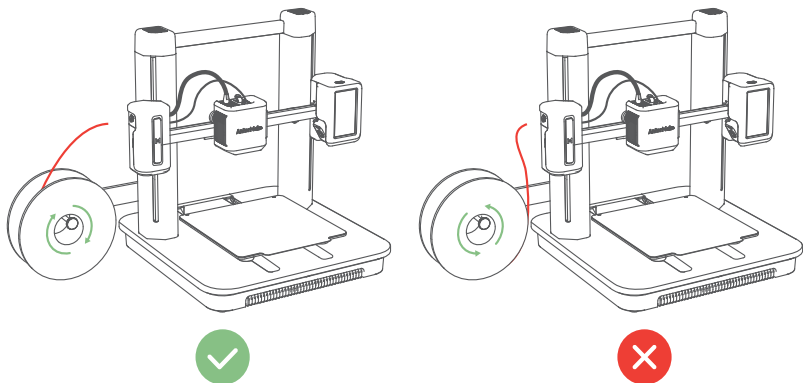

2. اقطع طرف الخيط بزاوية 45 درجة.

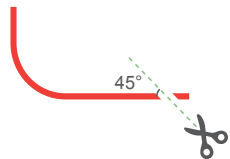

3. أدخل الخيط حتى يصل إلى البائق. بعد ذلك، اضغط مع الاستمرار على الزر الموجود أعلى البائق وواصل إدخال الخيط. توقف عندما تشعر ببعض المقاومة.

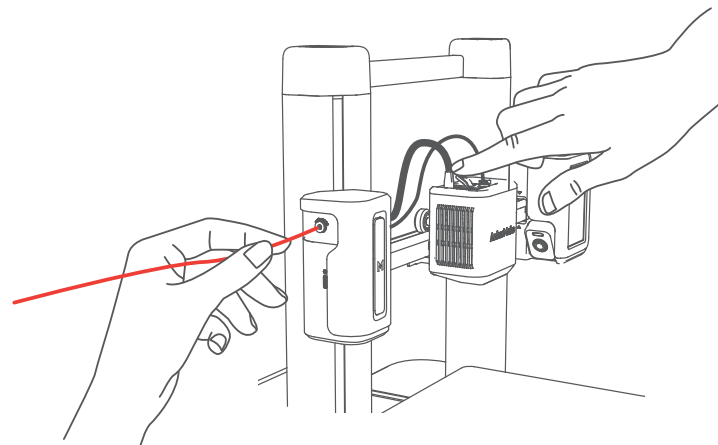

4. على الشاشة التي تعمل باللمس، انقر فوق **Control > Load > Extrude** (بثق).
انتظر حتى يتدفق الخيط خارج الفوهة، ثم انقر فوق **Stop** (إيقاف).

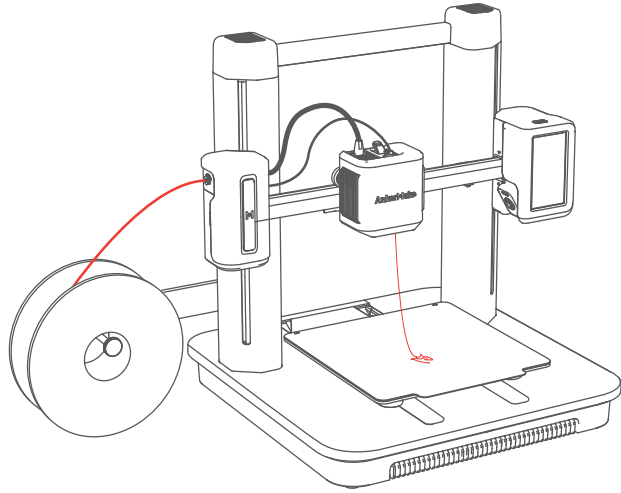

تثبيت برنامج ANKERMAKE SLICER

للحصول على أفضل تجربة طباعة، نزل برنامج AnkerMake Slicer وثبته على جهاز الكمبيوتر الخاص بك من fromankermake.com/software.

لن تتاح إمكانيات التعرف باستخدام الذكاء الاصطناعي عندما تعمل الطابعة مع برامج slicer أخرى مثل Cura وSimplify3D. 💡

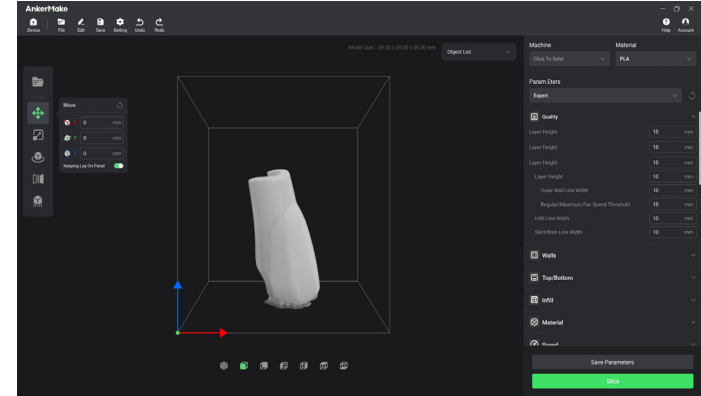

السلامة

- يجب توصيل سلك الطاقة بمخرج المقيس مع وصلة تأريض.
- يجب تثبيت مصدر الطاقة بالقرب من الجهاز؛ لتسهيل التوصيل بالمقيس.
- استخدم سلك الشاحن الأصلي المُقَدَّم من الشركة المصنعة فقط. قد يتسبب استخدام أسلاك طاقة غير مصرح به في التعرض لخطر وانتهاك ترخيص المنتج وكذلك الضمان.
- يعد قابس سلك الطاقة بمثابة جهاز فصل. بمجرد فصل السلك عن الكهرباء، يُعتبر المنتج منفصلاً عن مصدر الطاقة.
- لا تستخدم الجهاز في بيئة ذات درجة حرارة عالية جدًا أو منخفضة جدًا. ولا تُعرض الجهاز أبدًا لأشعة الشمس القوية أو لبيئات شديدة البرد.
- تتراوح درجة الحرارة المناسبة للمنتج وملحقاته من 15 إلى 35 درجة مئوية.
- يوصى بإمداد الجهاز بالطاقة في بيئة بدرجة حرارة تتراوح من 15 إلى 25 درجة مئوية.
- عند الإمداد بالطاقة، تأكد من وضع الجهاز في بيئة بدرجة حرارة الغرفة العادية وبتهوية جيدة.
- هذا الجهاز غير مناسب للاستخدام في الأماكن التي يحتمل وجود أطفال فيها. هذا الجهاز غير مخصص للاستخدام من قبل الأطفال.



- الأجزاء المتحركة. حافظ على بقاء أعضاء الجسم بعيدًا عن الأجزاء المتحركة.



- تنبيه من الأجزاء الساخنة. ممنوع للمس.
- اتبع طريقة استخدام المنتج الموصوفة ولا تستخدم أي طريقة مخالفة لتجنب الإصابة الشخصية أو تلف الممتلكات.
- يجب على المستخدم الامتنال للقوانين واللوائح المعمول بها في البلدان والمناطق المقابلة التي توجد بها المعدات (مستخدمة)، والالتزام بأخلاقيات المهنة، والاهتمام بالتزامات السلامة، وحظر استخدام منتجاتنا أو معداتنا تمامًا لأي أغراض غير قانونية. لن نتحمل شركتنا أي مسؤولية قانونية للمخالفين تحت أي ظرف من الظروف.

تم تصميم هذا المنتج وتصنيعه بمواد ومكونات عالية الجودة يمكن إعادة تدويرها وإعادة استخدامها.



يشير هذا الرمز إلى أنه يجب عدم التخلص من المنتج باعتباره من النفايات المنزلية العادية، بل يجب تسليمه إلى المنشأة المناسبة لتجميع النفايات بغرض إعادة التدوير. ويساعد التخلص من المنتج وإعادة تدويره بشكل صحيح على حماية الموارد الطبيعية وصحة الإنسان والبيئة. ولمزيد من المعلومات حول التخلص من هذا المنتج وإعادة تدويره، اتصل بالبلدية المحلية أو خدمة التخلص من النفايات أو المتجر الذي اشتريته منه هذا المنتج.





12-month limited warranty | 12 Monate
eingeschränkte Garantie | Garantía limitada de
12 meses | Garantie limitée de 12 mois | 12 mesi
di garanzia limitata | 12 meses de garantia
limitada | 通常保証 12 ヶ月 | 12 개월 제한 보증 |

ارْمش 12 تدمل دودحم نامض

Lifetime technical support | Technischer Support für die
Produktlebensdauer | Asistencia técnica de por vida | Assistance
technique à vie | Supporto tecnico per l'intero ciclo di vita |
Suporte técnico ao longo da vida útil do produto |
테크니컬サポート | 평생 기술 지원 | میاد ینوقت معد



www.ankermake.com



support@ankermake.com
support.mea@anker.com (Middle East & Africa)
CED-CN@anker.com (中国)
support@anker.com (日本)



(US) +1 (800) 221-0126 Mon-Fri 6:15AM - 5:00PM(PT)
(UK) +44(0)1604 936200 Mon-Sat 6:00-19:00 Sun 6:00-14:00
(DE) +49(0)69 9579 7960 Mo-Fr 8:00 - 16:00
(Middle East & Africa) +971 42428633 Mon-Thu 9:00 - 17:30 Fri 8:00 - 12:00
(UAE) +971 8000320817 Mon-Thu 9:00-17:30 Fri 8:00 - 12:00
(KSA) +966 8008500030 Mon-Thu 8:00-16:30 Fri 7:00 - 11:00
(Kuwait) +965 22069086 Mon-Thu 8:00-16:30 Fri 7:00 - 11:00
(Egypt) +20 8000000826 Mon-Thu 7:00 - 15:30 Fri 6:00 - 10:00
(AU) +61 3 8331 4800 Mon-Fri 8:30 - 17:00(AEST)
(TR) +90 (850) 460 14 14 Mon-Fri 9:00 - 18:00
(RU) +8(800)511-86-23 Mon-Fri 9:00 - 18:00(MSK)
(中国) +86 400 0550036 周一至周五 9:00-18:00
(日本) 03 4455 7823 平日 9:00-17:00 / 年末年始を除く
(한국) +82 02-1670-7098 -- 10:00-17:00

Anker Innovations Limited Room 1318-19, Hollywood Plaza, 610 Nathan
Road, Mongkok, Kowloon, Hong Kong