

Bild 2: Netzteilplatine

nip: not in place

zur Treiberplatine

zur Netzteilplatine

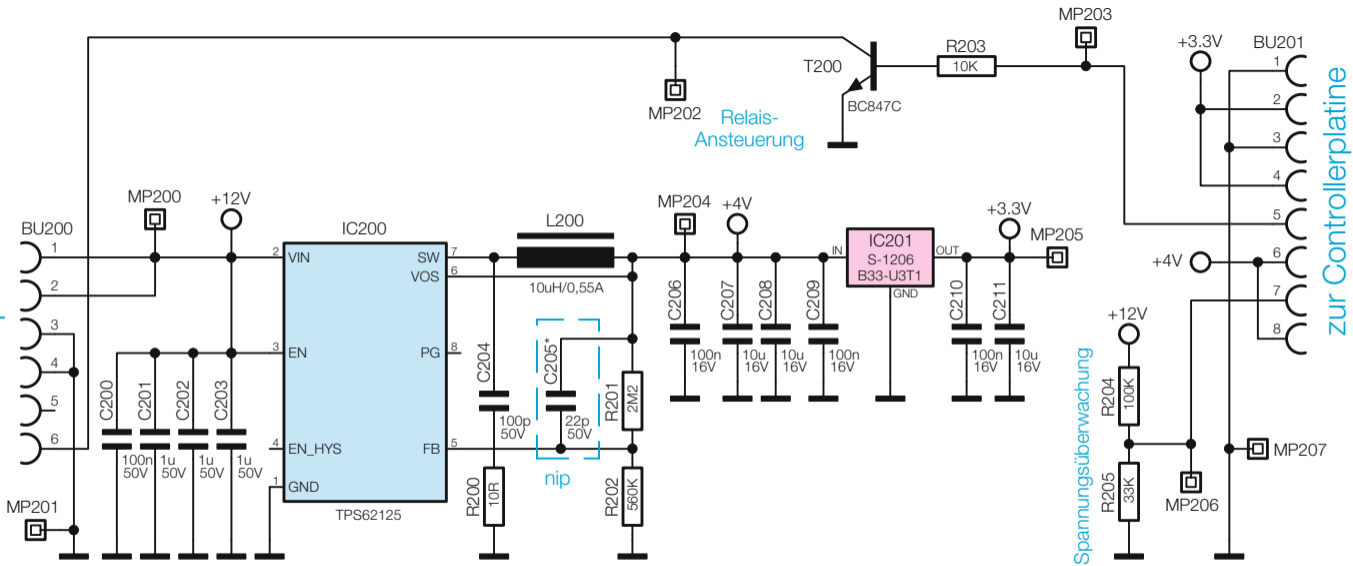

zur Controllerplatine

Spannungsüberwachung

Bild 3: Treiberplatine

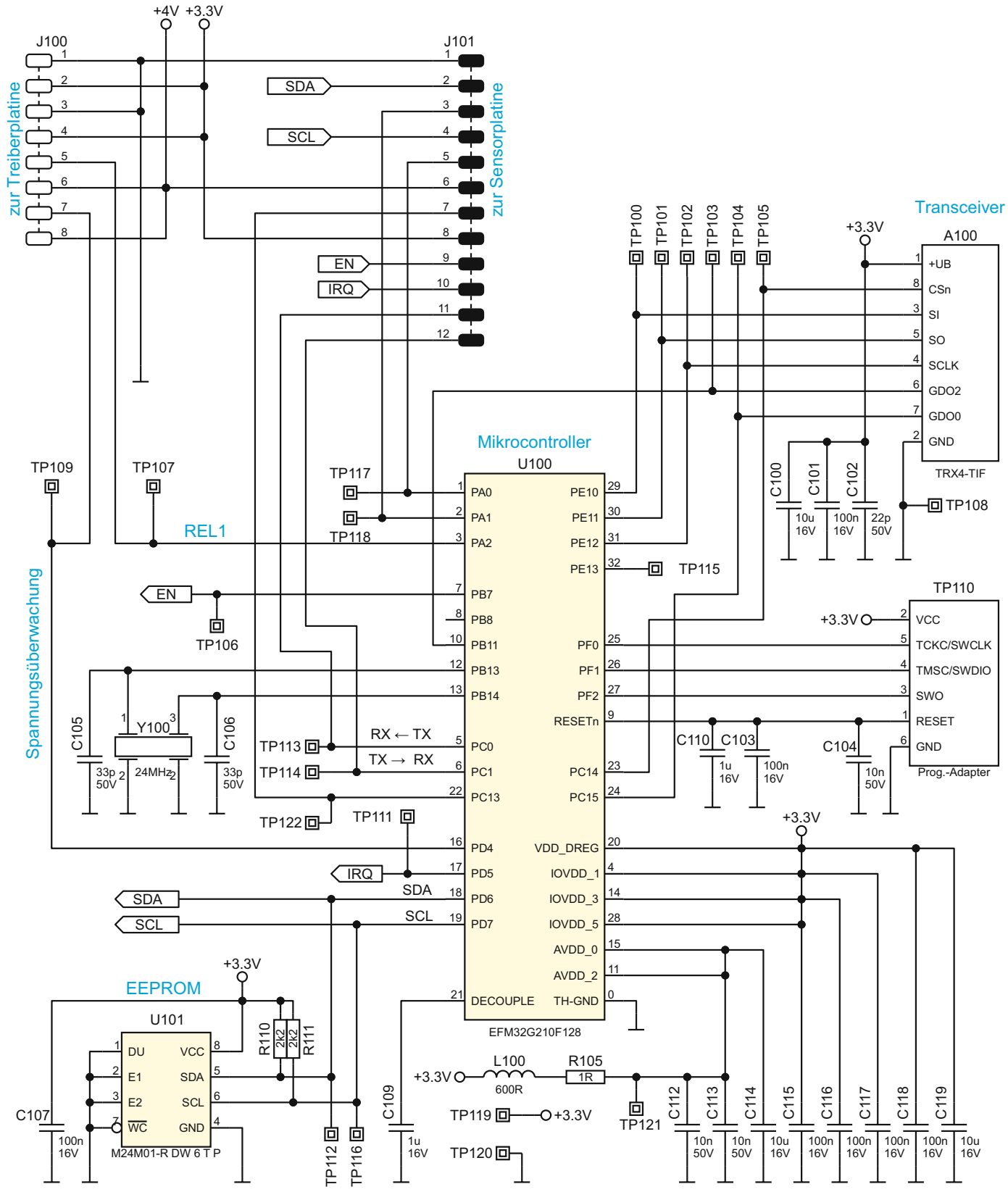

Bild 4: Controllerplatine

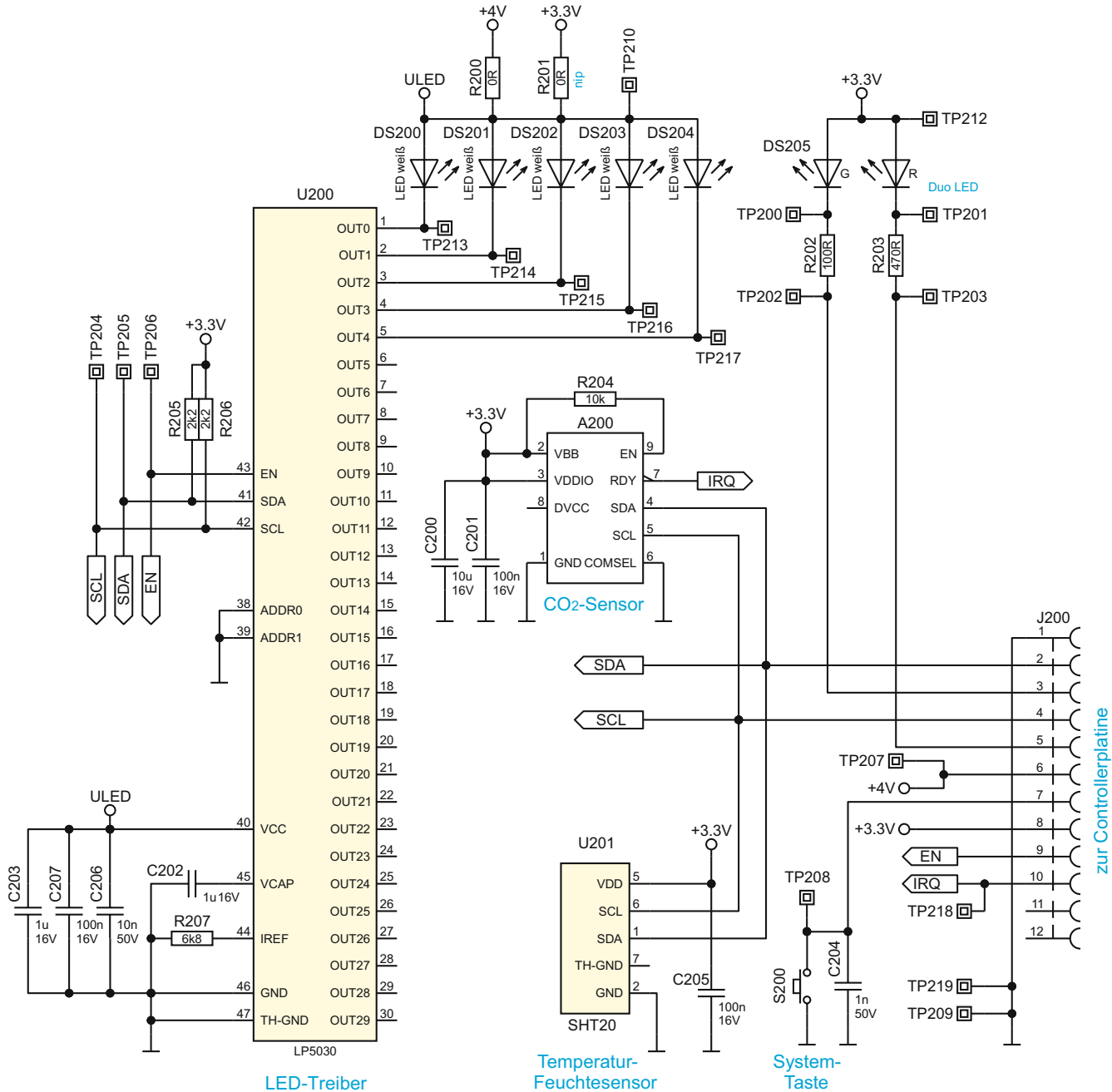

zur Controllerplatine

Bild 5: Sensorplatine