

# Kleinsignalspannung

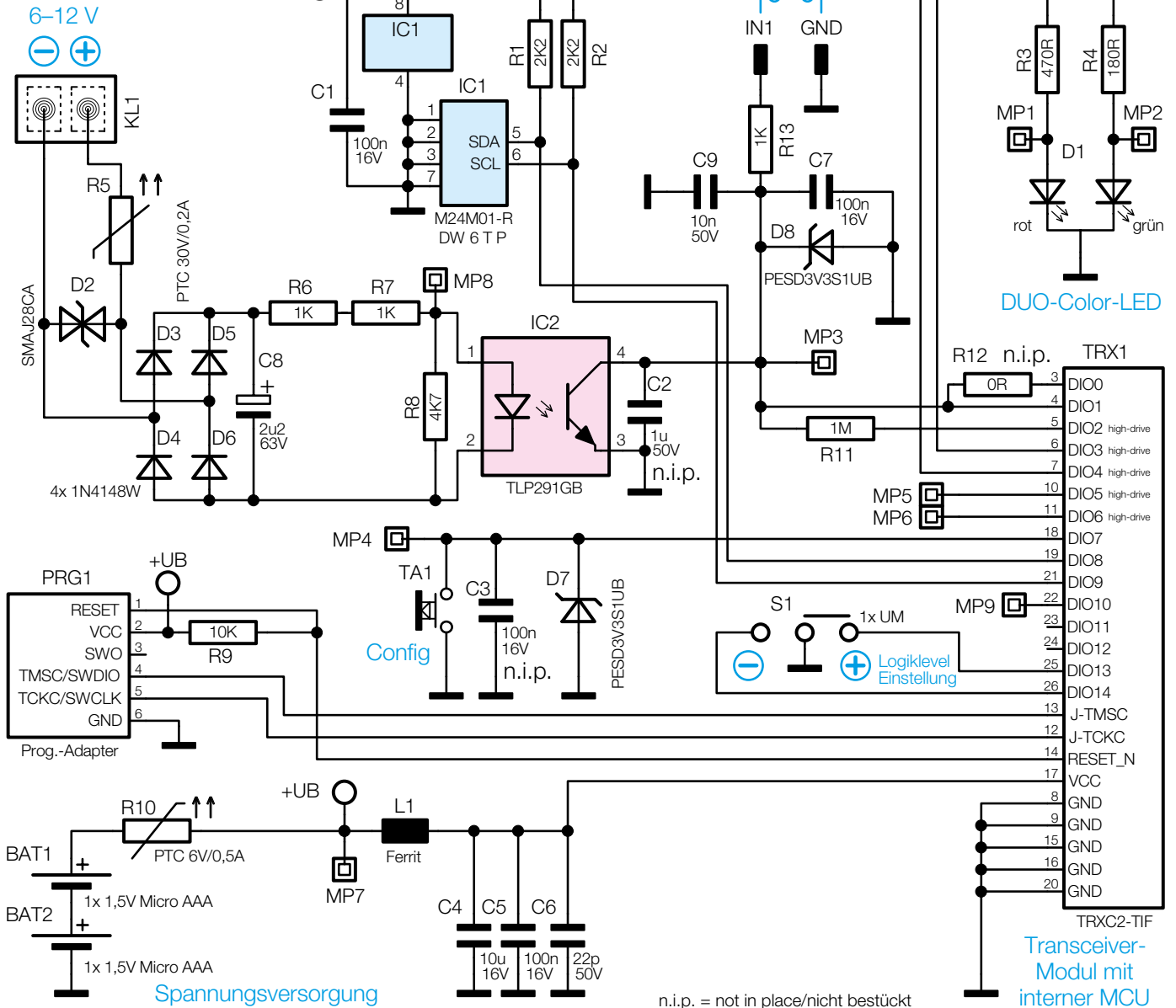

- |    |                 |
|----|-----------------|
| 3  | DIO0            |
| 4  | DIO1            |
| 5  | DIO2 high-drive |
| 6  | DIO3 high-drive |
| 7  | DIO4 high-drive |
| 10 | DIO5 high-drive |
| 11 | DIO6 high-drive |
| 18 | DIO7            |
| 19 | DIO8            |
| 21 | DIO9            |
| 22 | DIO10           |
| 23 | DIO11           |
| 24 | DIO12           |
| 25 | DIO13           |
| 26 | DIO14           |
| 13 | J-TMSC          |
| 12 | J-TCKC          |
| 14 | RESET_N         |
| 17 | VCC             |
| 8  | GND             |
| 9  | GND             |
| 15 | GND             |
| 16 | GND             |
| 20 | GND             |
- TRXC2-TIF