

Bild 16: Lithium-Akku-Ladeschaltung

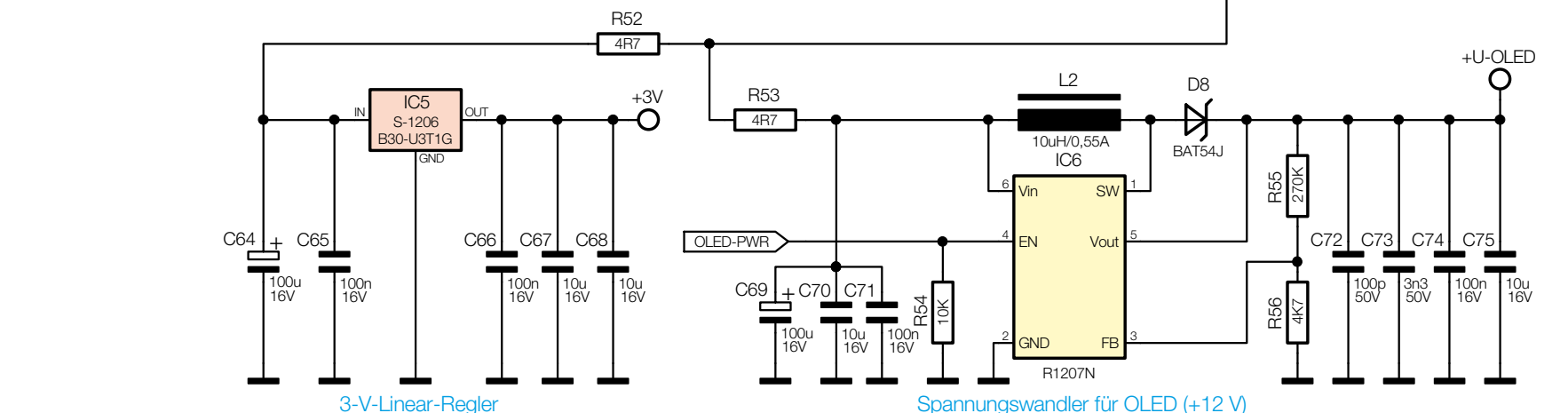

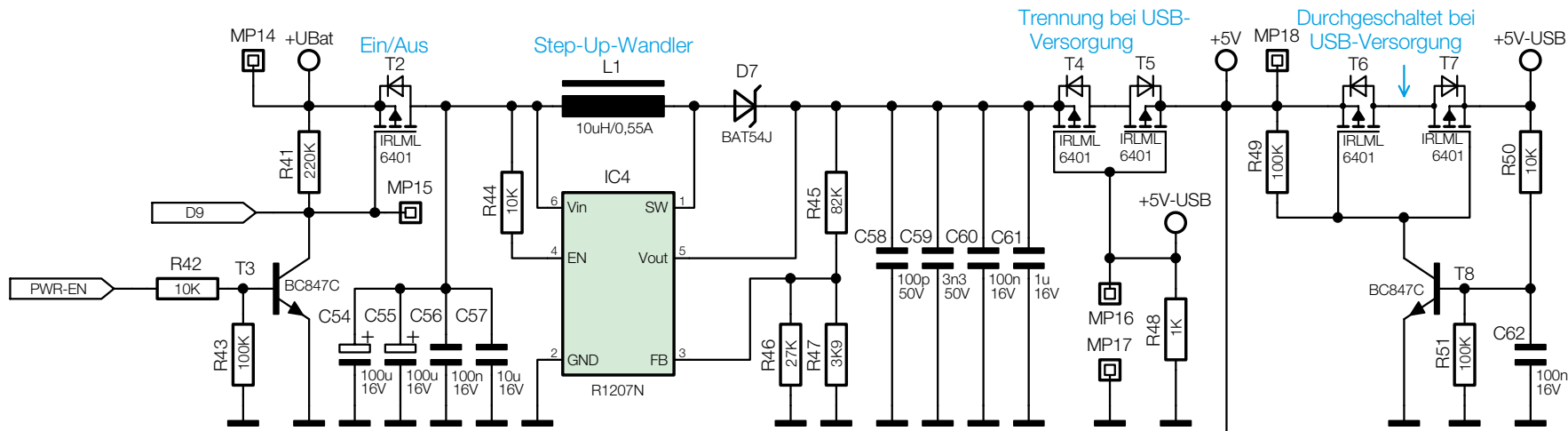

Bild 18: Mikrocontroller-Einheit des Feinstaub-Messgeräts PM2.5



Bild 19: OLED-Displayeinheit

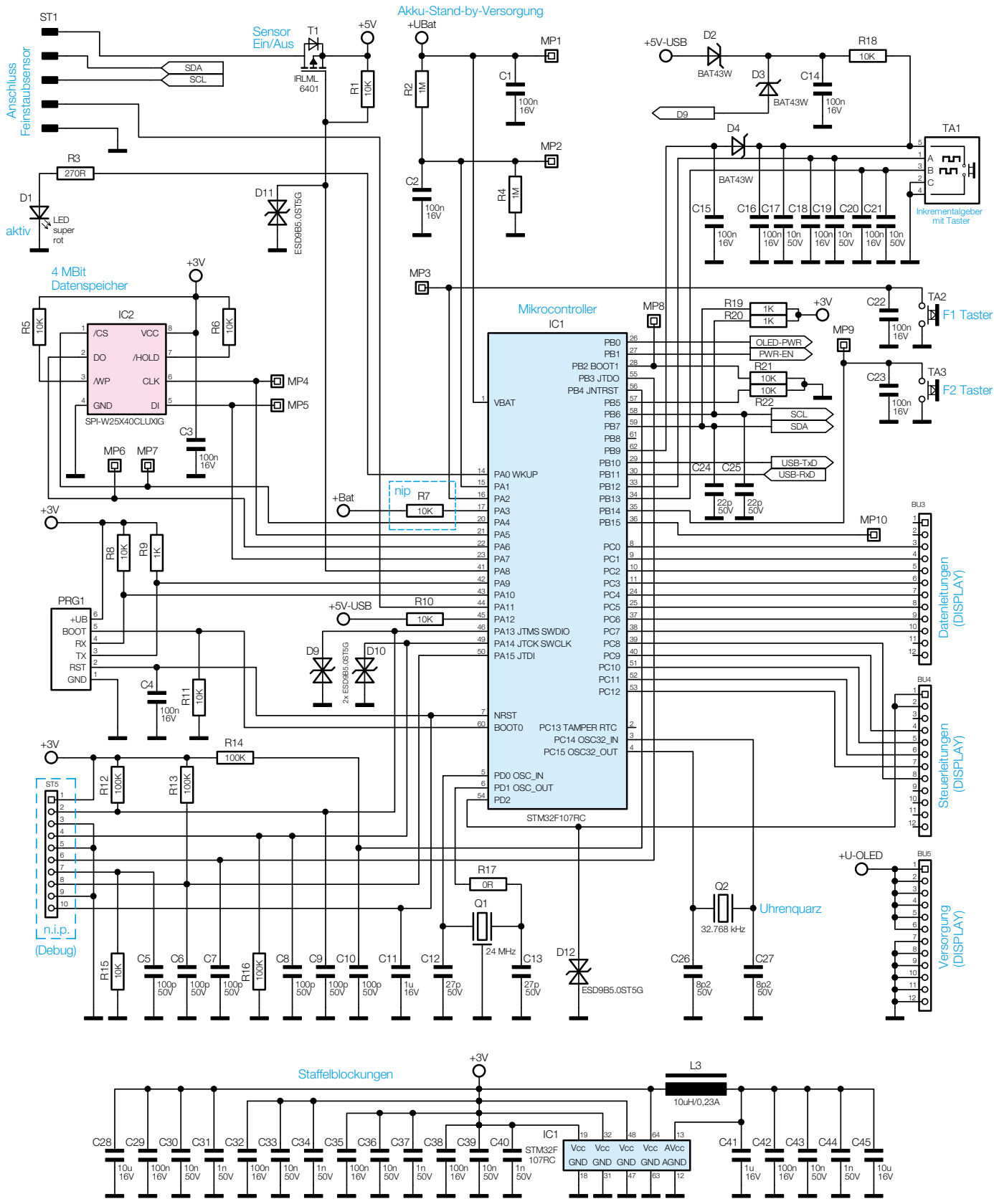
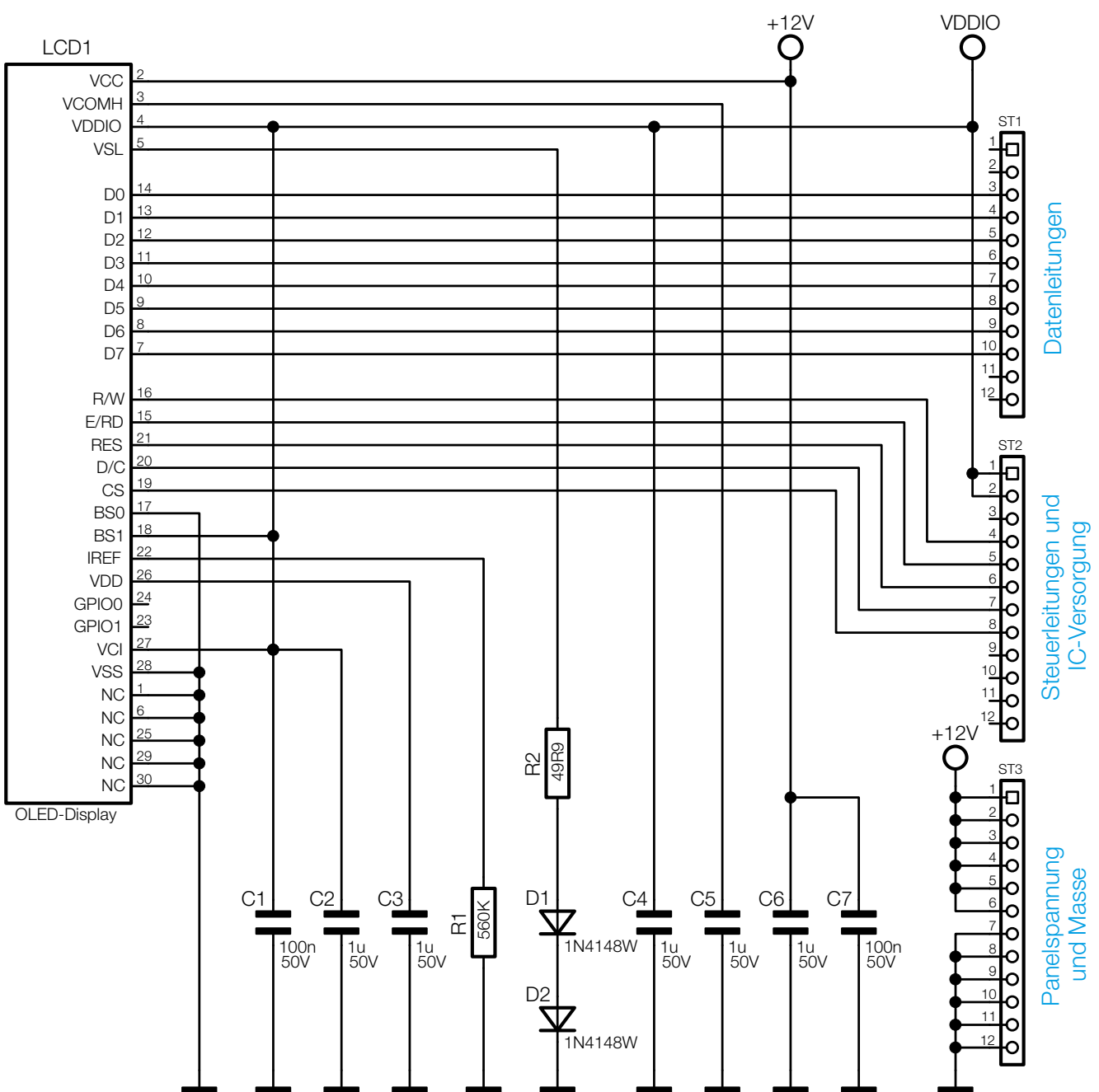
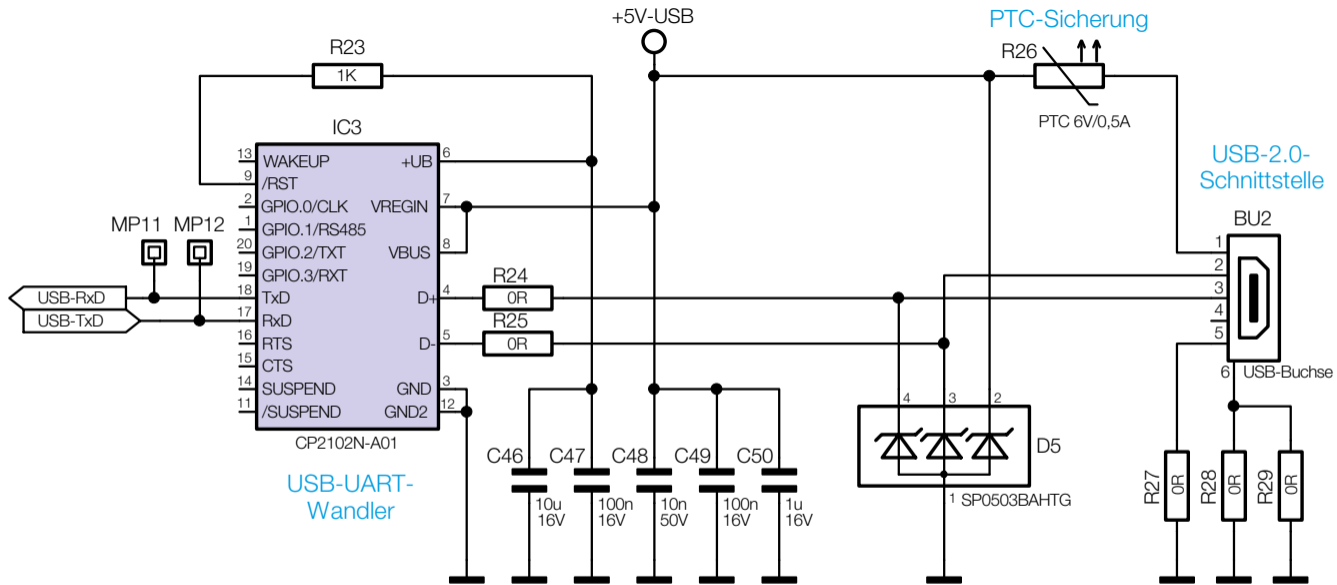

Bild 20: USB-Schnittstelle des Feinstaub-Messgeräts PM2.5