

**Datenblatt Artikelnr.: 7450.00.0080.00**

|                            |              |
|----------------------------|--------------|
| NEON GLOW LAMP (Lead Free) | 13/30SHB     |
| 6x13mm SHB                 | NOMENCLATURE |

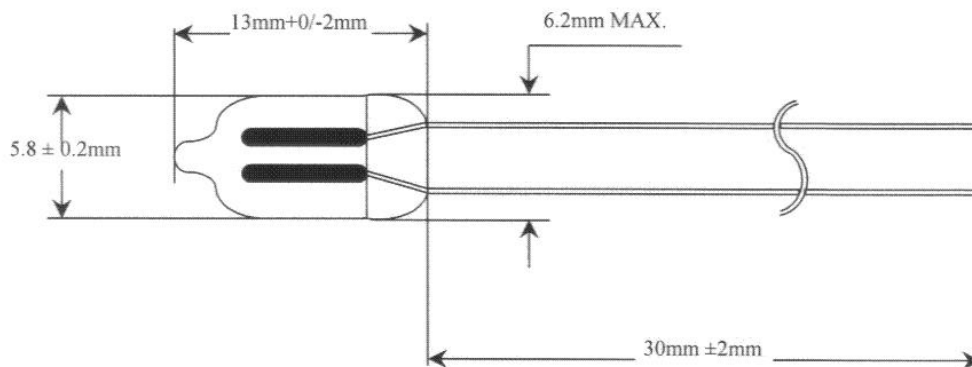

|                 |                          |                        |
|-----------------|--------------------------|------------------------|
| STRUCTURE       | GLASS BULB TYPE          | T6.2mm MAX.            |
|                 | BULB LENGTH              | 13mm+0/-2mm            |
|                 | BASE                     | PLATED WIRE - TERMINAL |
|                 | WIRE – TERMINAL LENGTH   | 30mm±2mm               |
| SEIRES RESISTOR | 110/130V AC              | 33K OHM 1/4W           |
|                 | 220/250V AC              | 100K OHM 1/4W          |
| INITIAL         | CURRENT                  | 1.5mA ±15%             |
| CHARACTERISTICS | MAXIMUM STRIKING VOLTAGE | 95V (AC) 135V (DC)     |
|                 | BRIGHTNESS               | SUPER HIGH             |
| LIFE            | AVERAGE LIFE             | 15,000-25,000 HOURS    |
| GLASS           | LEAD GLASS TUBE          |                        |
| LEAD WIRES      | DUMET WIRES              |                        |
| ELECTRODES      | NICKEL                   |                        |