

Bild 20: Das Schaltbild des Ferraris-Stromzählersensors ES-Fer (rechts im Bild)

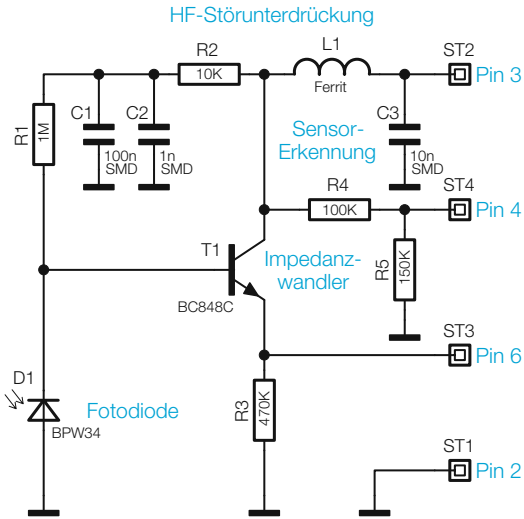

Bild 21: Das Schaltbild des LED-Stromzählersensors ES-LED, rechts im Bild

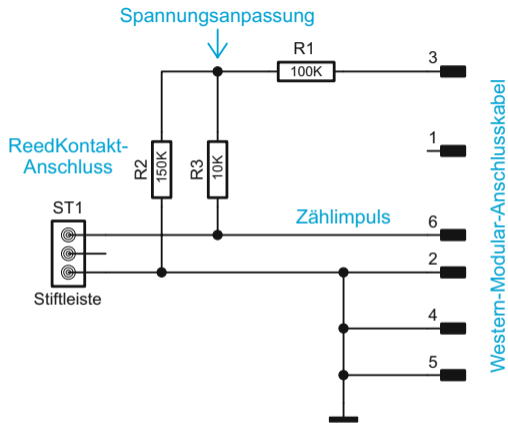

Bild 22: Das Schaltbild des Gaszählersensors ES-Gas, Bild rechts