

Bild 15: Spannungsversorgung des RGBW200



Bild 16: Mikrocontroller-Einheit des RGBW200



Bild 17: OLED-Displayeinheit des RGBW200

Sensorgehäuse

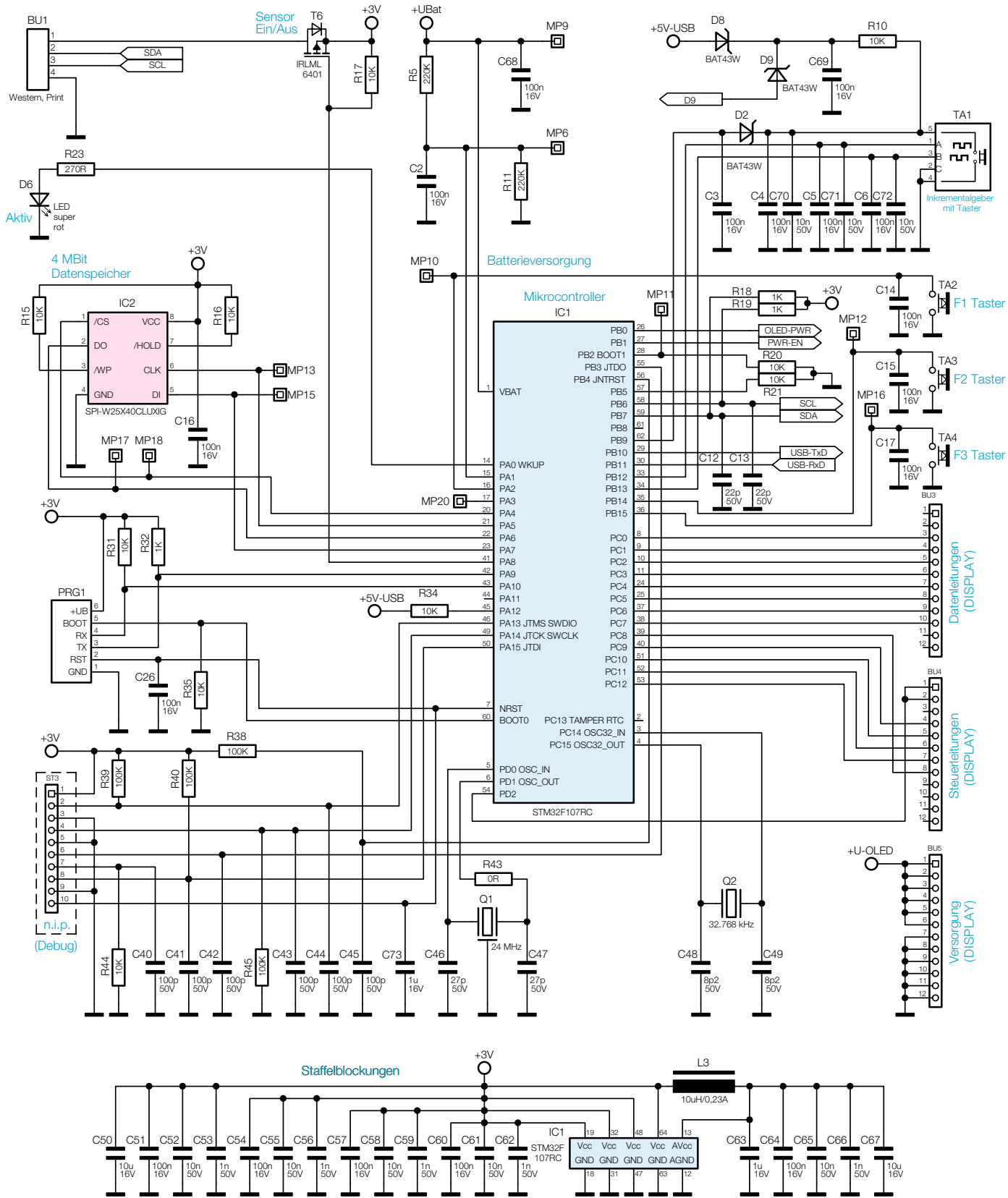

Bild 18: Sensoreinheit des RGBW200

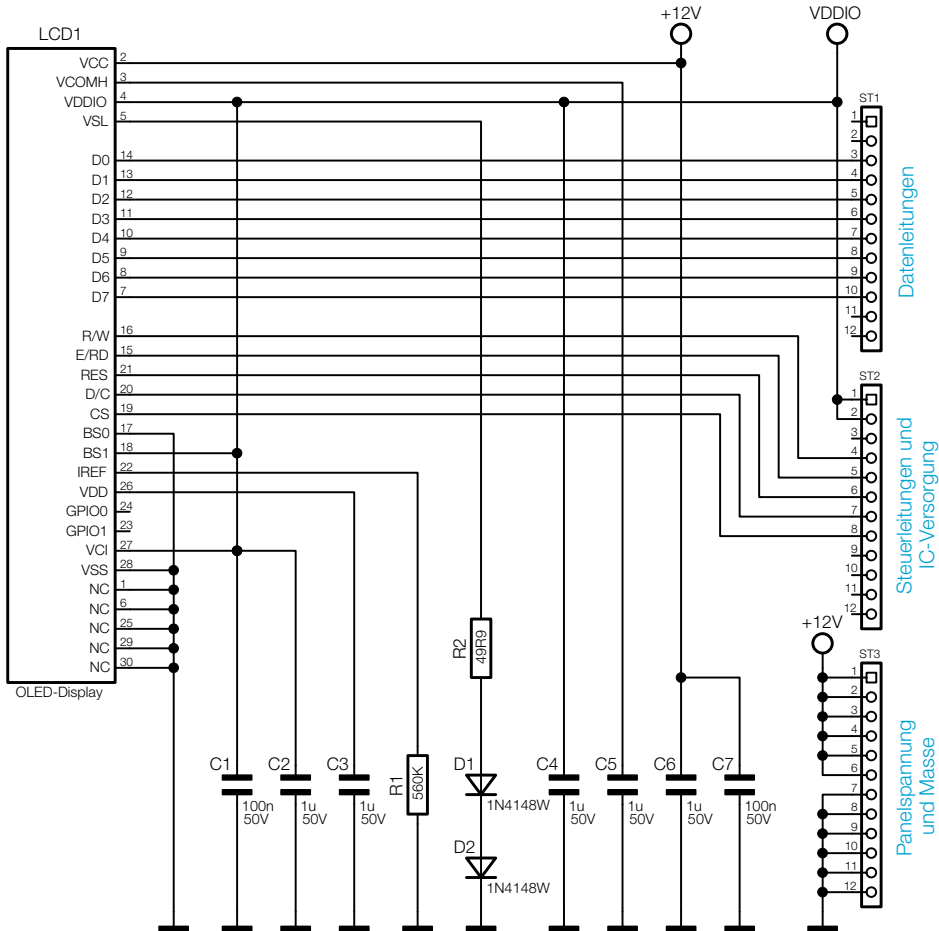
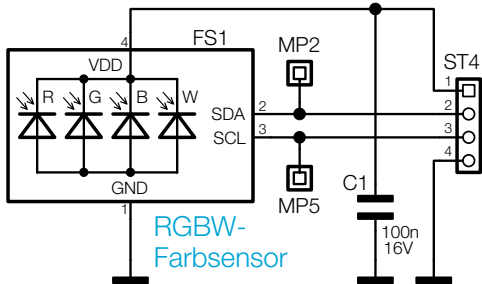
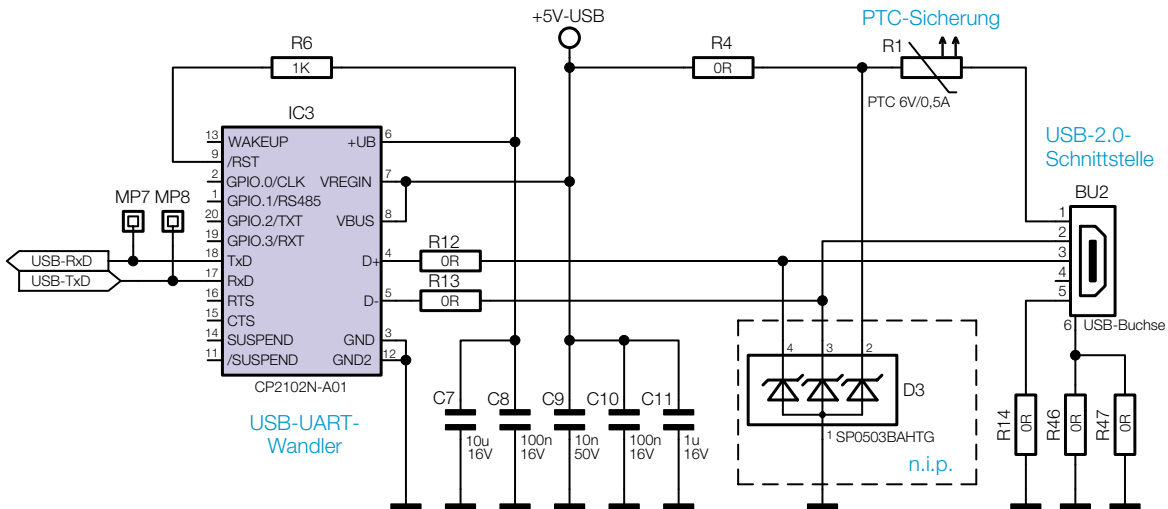

Bild 19: USB-Schnittstelle des RGBW200