

CAD FILE :

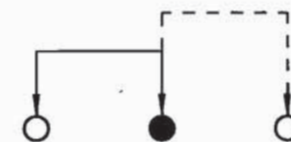

SCHEMATIC (NON-SHORTING)

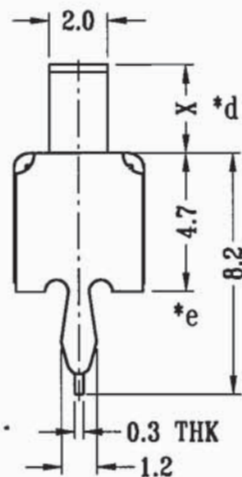
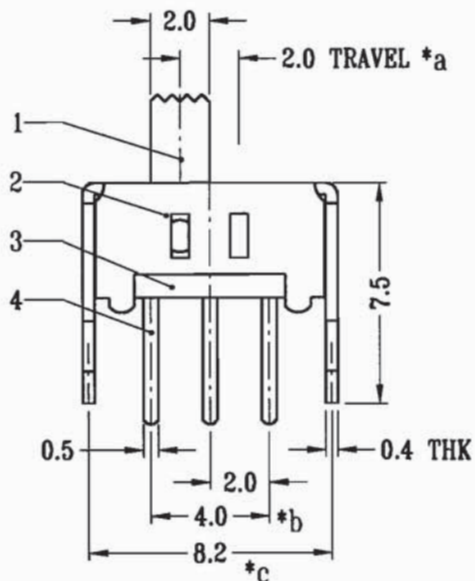
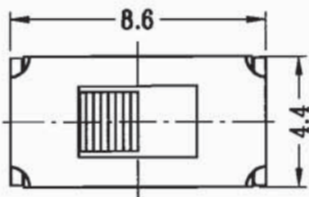
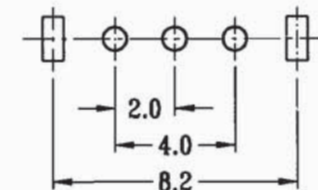

P.C.B LAYOUT

注：“*”表示關鍵尺寸(5個)

8										
7										
6	SPRING PLATE	STAINLESS STEEL	1	NATURAL	TOLERANCE UNLESS SPECIFIED					
5	CONTACT CLIP	PBS C5210R-EH	1	Ag CLAD		WITHIN 1.5±0.1mm	A	3/5/2002	初版	
4	TERMINAL	BRASS STRIP	3	Ag PLATED OVER Ni PLATED	OVER 1.5±0.2mm	ISSUE	DATE	DESCRIPTIONS	APPD	
3	TERMINAL BASE	PHENOLIC RESIN	1	NATURAL	TITLE: VERTICAL SLIDE SWITCH		UNIT : M M	DRWG NO :SF-DR-SS12D22-00		
2	FRAME	STEEL STRIP	1	Ni PLATED	MODEL: SS-12D22		SCALE : 4:1	DWN.	3/5/2002	
1	KNOB	POM	1	BLACK	Hua-Jie (Taiwan) Corp.			CHK'D	3/5/2002	
NO.	PART NAME	MATERIAL	QTY.	FINISHING				APPD.	3-5-02	