

Bild 1: Schaltbild der einzelnen Spannungsversorgungen

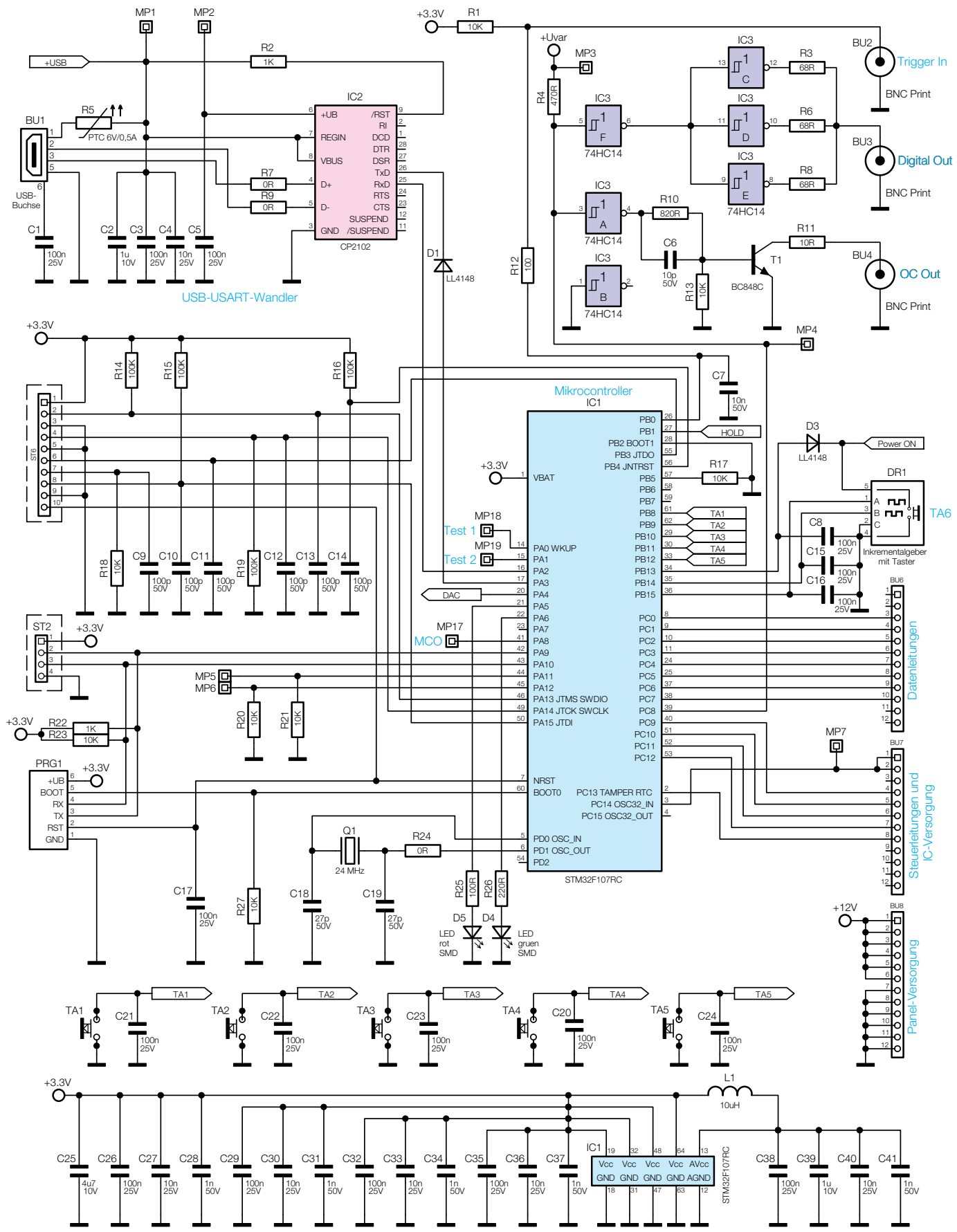

Bild 2: Schaltbild des Mikrocontrollers mit angeschlossener Peripherie

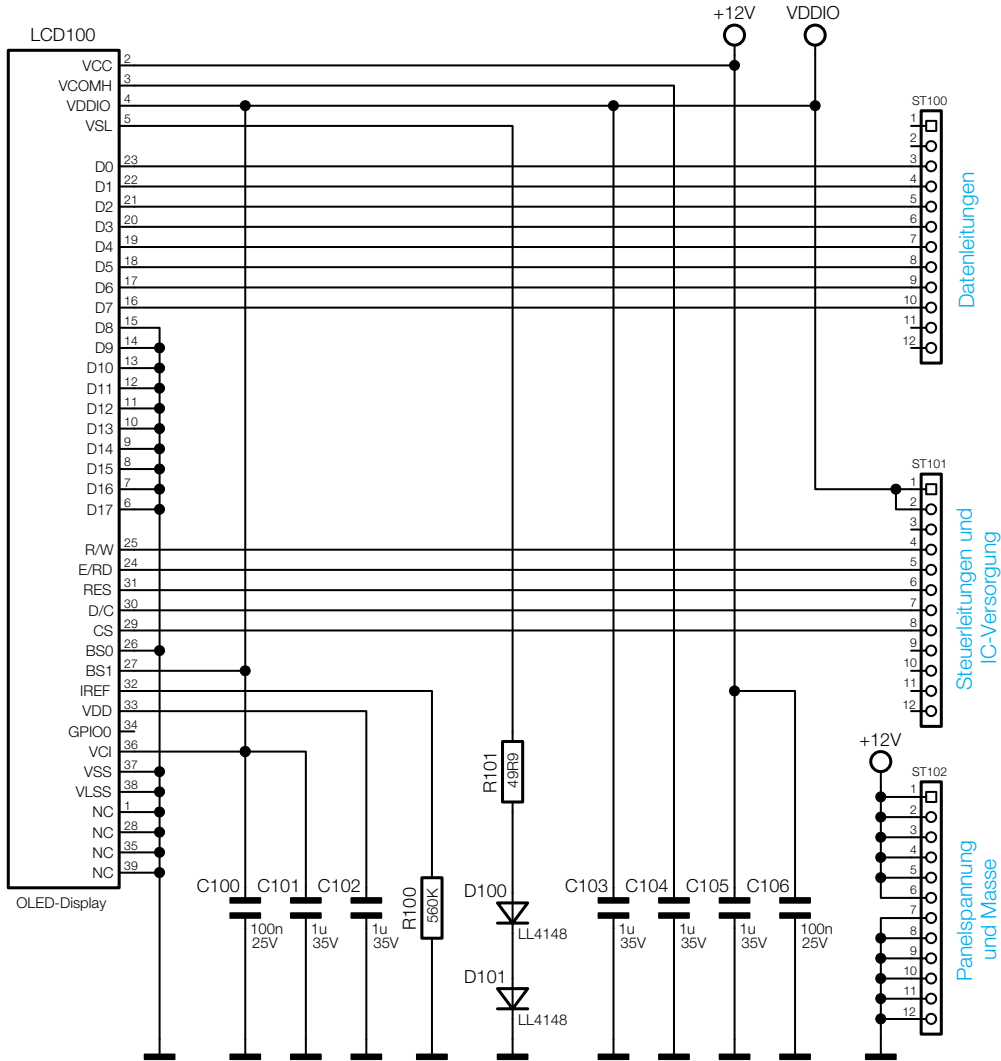

Bild 3: Schaltbild des OLED-Displays