

LEDW10_24 Series

Constant current power LED driver - Wide Input - Isolated & Regulated

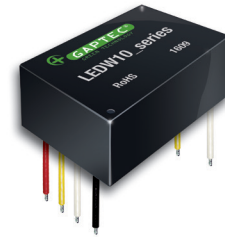

LED Driver

- ⊕ Ultra wide range voltage input (5.5-48VDC)
- ⊕ High efficiency up to 96%
- ⊕ Short Circuit Protection (SCP)
- ⊕ Remote ON/OFF
- ⊕ Lead wire package, simple and convenient
- ⊕ Waterproof Level IP67
- ⊕ With large capacitive loads (1000 μ F)
- ⊕ AC-DC, EMC recommended circuit
- ⊕ PWM dimming & analogue dimming
- ⊕ Low ripple & noise (<100mV)
- ⊕ RoHS Compliance



The LEDW10_24 is a high-power LED driver designed for the step-down constant current source. With high efficiency, wide input voltage range, high-temperature environment, functional and so on. Contains a PWM dimming, analog dimming and remote shutdown capabilities.

It can be widely used in backlight and 12V, 24V, 36V landscape lighting, special lighting controls, commercial lighting, street lighting, home lighting, automotive lighting and other lighting systems. Use of lead type package, allowing customers to use more convenient.

Specifications					
Item	Test condition	Min	Typ	Max	Units
Input voltage limit	≤ 10 seconds	5		55	VDC
Input voltage range		5.5	24	48	VDC
Min. Input-output Voltage Drop	Vin=5.5~48V, 1~10LEDs	2		4	VDC
Input filter	Capacitor				
Internal power dissipation	Vin=24V, 5LEDS			700	mW
Output voltage range	Vin=48V	3.3		36	VDC
Output power	• Io: 300mA • Io: 350mA • Io: 500mA • Io: 600mA • Io: 700mA	0.99 1.16 1.65 1.98 2.31		10.8 12.6 18 21.6 25.2	W
Output current accuracy			± 2	± 5	%
Output current stability	Vin=48V, Vo=3.3V~36V			± 1	%
Temperature coefficient	-40°C to +71°C ambient			± 0.015	%/°C
Ripple & Noise*	20MHz bandwidth			100	mV
Thermal impedance			60		°C/W
Short circuit protection	Continuous, automatic recovery				
Operating temperature range	• 300mA/350mA • 500mA/600mA/ 700mA	-40 -40		85 71	°C
Storage temperature		-55		105	°C
Maximum case temperature				100	°C
Lead temperature	1.5mm away from the casing, 10 seconds			265	°C
Humidity				95	%
Switching frequency		320	370	420	kHz
MTBF	MIL-HDBK-217F(+25°C)		1500		kHours
Case Material	Epoxy Resin (UL94-V0)				
Dimensions		22.30	12.55	9.10	mm
Weight			8.2		g

* Ripple and noise tested with "parallel cable" method, please see DC-DC Converter Application Notes for specific operation methods.

PWM dimming and ON/OFF control (leave open if not used)

Item	Test condition	Min	Typ	Max	Units
Remote ON/OFF	• ON • OFF (shutdown)			Open or 2.8V<Vc<6V Vc<0.6V	
Suspended voltage	Vin=24V, 5LEDS		3.3		V
Turn-off-mode static input current	Vin=24V, Vc <0.6V		400		μ A
Isink	Vc=5V, Vin=24V, 5LEDS			1	mA
Isourse	Vc<0.6V, Vin=24V, 5LEDS		1		mA
PWM frequency*	refer to PWM dimming control			200	Hz

*Refer to "PWM Dimming Control"

Analogue dimming (leave open if not used)

Item	Test condition	Min	Typ	Max	Units
Input voltage range	Vin=5.5-48V			0-15V	
Output current range	Vin=5.5-48V			0%-100%	
Control voltage range	• Full on • Full off			0.2V \pm 50mV 4.5V \pm 200mV	
Driving current	Vc=5V			0.6mA (max)	

Model selection:

LEDC_xx-###
LEDC=Type; C=Case; yy=Vin; ###= Output Current

Example:

LEDW10_24-300
LED= Series W= wired; yy= 24VDC nominal; 300= 0,3A

Note:

1. If the product is not operated within the required load range, the product performance cannot be guaranteed to comply with all parameters in the datasheet;
2. The maximum capacitive load offered were tested at nominal input voltage and full load;
3. Unless otherwise specified, parameters in this datasheet were measured under the conditions of Ta=25°C, humidity<75% with nominal input voltage and rated output load;
4. All index testing methods are based on our Company's corporate standards;
5. We can provide product customization service;
6. Specifications are subject to change without prior notice.

LEDW10_24 Series

Constant current power LED driver - Wide Input - Isolated & Regulated

EMC specifications				
EMI	Conducted disturbance	EN55022 /CISPR22	CLASS B	EN55015 power port*
EMI	Radiated Emission	EN55022 /CISPR22	CLASS B*	
EMS	Electrostatic Discharge	IEC/EN61000-4-2 IEC/EN61000-4-2	Contact ±2KV Contact ±6KV	perf. Criteria B perf. Criteria B*
EMS	Radiation Immunity	IEC/EN61000-4-3	10V/m	perf. Criteria A
EMS	EFT	IEC/EN61000-4-4	±1KV	perf. Criteria B*
EMS	Surge Immunity	IEC/EN61000-4-5	±1KV	perf. Criteria B*
EMS	CS	IEC/EN61000-4-6	3 Vr.m.s	perf. Criteria A
EMS	Immunities of voltage dip, drop and short interruption	IEC/EN61000-4-29	0%-70%	perf. Criteria B

* Refer to EMC solution-recommended circuit

Part Number	Input Voltage [VDC] Nominal (Range)	Output Voltage [VDC]	Output Current [mA]	Max. capacitive load [µF]	Efficiency [% , typ]
LEDW10_24-300	24 (5.5-48)	3.3-36	0-300	1000	96
LEDW10_24-350	24 (5.5-48)	3.3-36	0-350	1000	96
LEDW10_24-500	24 (5.5-48)	3.3-36	0-500	1000	96
LEDW10_24-600	24 (5.5-48)	3.3-36	0-600	1000	96
LEDW10_24-700	24 (5.5-48)	3.3-36	0-700	1000	96

Input vs. Output

Input voltage	Output voltage range [VDC]	Output constant current [mA]	Output power [W, max]
48	3.3-36.0	300	10.80
36	3.3-32.0	300	9.60
24	3.3-21.0	300	6.30
20	3.3-17.0	300	5.10
15	3.3-13.2	300	3.96
12	3.3-10.0	300	3.00
5.5	3.3-4.0	300	1.20

Input voltage	Output voltage range [VDC]	Output constant current [mA]	Output power [W, max]
48	3.3-36.0	600	21.60
36	3.3-32.0	600	19.20
24	3.3-21.0	600	12.60
20	3.3-17.0	600	10.20
15	3.3-13.2	600	7.92
12	3.3-10.0	600	6.00
5.5	3.3-4.0	600	2.40

Input voltage	Output voltage range [VDC]	Output constant current [mA]	Output power [W, max]
48	3.3-36.0	350	12.60
36	3.3-32.0	350	11.20
24	3.3-21.0	350	7.35
20	3.3-17.0	350	5.95
15	3.3-13.2	350	4.62
12	3.3-10.0	350	3.50
5.5	3.3-4.0	350	1.40

Input voltage	Output voltage range [VDC]	Output constant current [mA]	Output power [W, max]
48	3.3-36.0	700	25.20
36	3.3-32.0	700	22.40
24	3.3-21.0	700	14.70
20	3.3-17.0	700	11.90
15	3.3-13.2	700	9.24
12	3.3-10.0	700	7.00
5.5	3.3-4.0	700	2.80

Input voltage	Output voltage range [VDC]	Output constant current [mA]	Output power [W, max]
48	3.3-36.0	500	18.00
36	3.3-32.0	500	16.00
24	3.3-21.0	500	10.50
20	3.3-17.0	500	8.50
15	3.3-13.2	500	6.60
12	3.3-10.0	500	5.00
5.5	3.3-4.0	500	2.00

LEDW10_24 Series

Constant current power LED driver - Wide Input - Isolated & Regulated

Typical application circuits

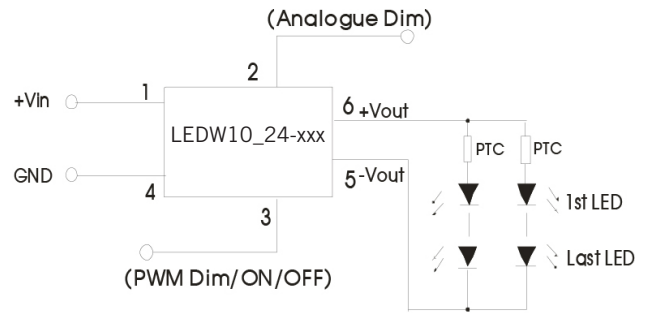
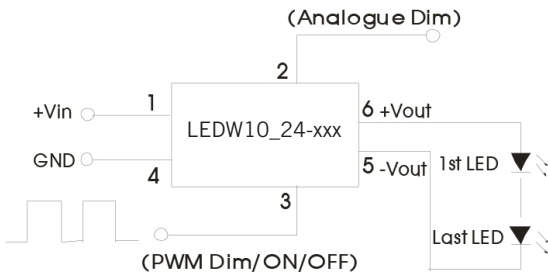

If it is necessary to protect LED in actual application, you could connect a PTC to the input of every channel or all channels, as shown in Recommended AC input circuit.

Note: The negative output terminal can't connect GND, or the module may be damaged.

Recommended AC input circuit

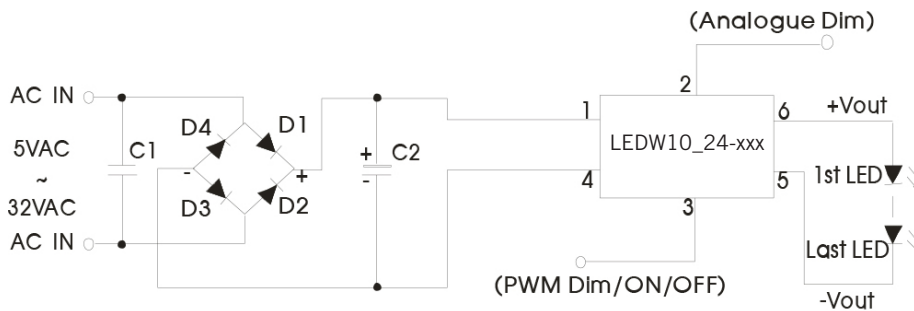

Components	Specifications
C1	X1 Safety capacitor, 0.1µF /300VAC (QIYA)
C2	100µF /63V Electrolytic capacitor (CapXon)
D1, D2, D3, D4	Rectifier diode 1N4007 1A/1000V D0-41(PANJIT)

EMC solution-recommended circuit

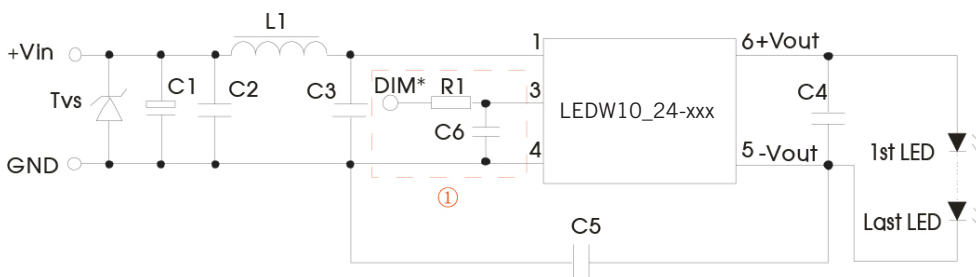

Components	Specifications
Tvs	SMC51A, 1500W (Bringtking)
L1	CD53-82µH (CEAIYA)
C1	470µF/100V (CapXon)
C2	225K/50V 1210 X7R (TORCH)
C3	104K/50V 0805 X7R (TORCH)
C4	105K/50V 1210 X7R (TORCH)
C5	102K/2000V 1210 (TDK) (choose)
C6	470pF/100V 0805 (TORCH)
R1	680Ω 0805 (can be replaced by inductance or magnetic bead)

LEDW10_24 Series

Constant current power LED driver - Wide Input - Isolated & Regulated

EMI/RFI conducted EN55022 Class B recommended circuit

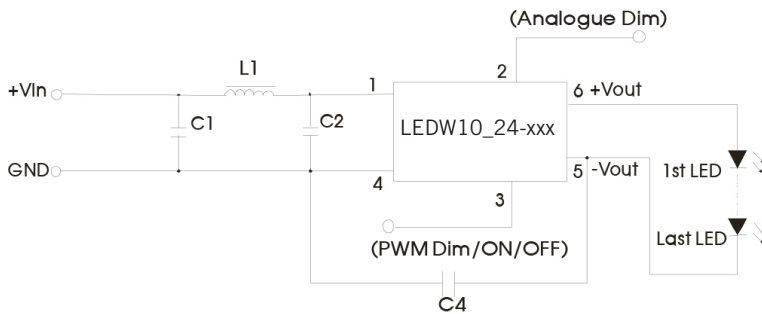

Components	Specifications
C1	225K/50V 1210 x7R (TORCH)
C2, C4	104K/50V 1210 x7R (TORCH)
L1	PI043-131MT (SHENZHEN CEAIYA)

PWM dimming control

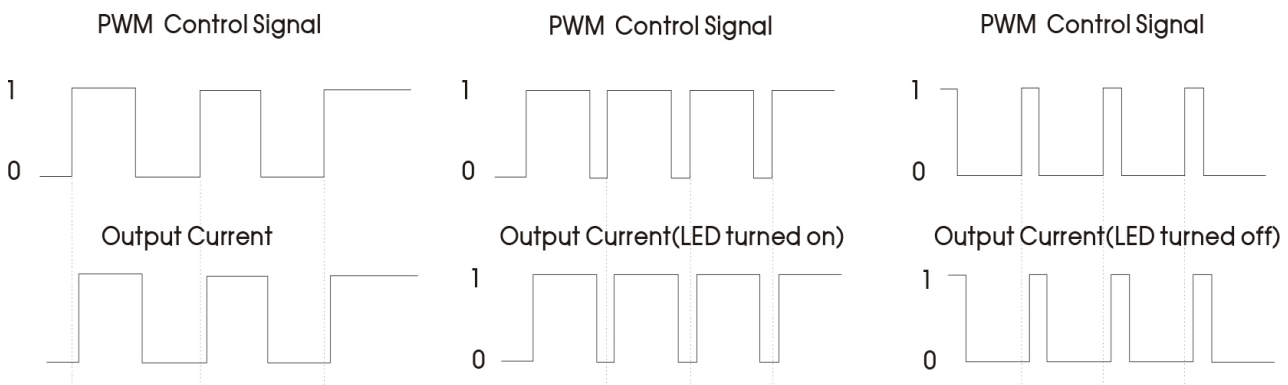

For PWM dimming signals with a certain frequency, the output current of the driver is related to the duty ratio of PWM signal. Refer to the formula for the calculation method:

$$I_{o_set} = \frac{(DT-0.8)}{T} I_{o_norm}$$

Where, I_{o_set} represents required output current (mA); D represents the duty ratio (%) of PWM signal; T represents the period (ms) of PWM signal; and I_{o_norm} represents the rated output value (mA) of the driver.

Note: The formula is for reference only; and deviation of output current may exist due to various loads. The min. conducted time of PWM signal shall not be less than 0.8ms, or the product will be in abnormal operation; in case of low voice from the driver during PWM dimming, it is normal since the PWM dimming frequency is within the auditory frequency range of human ears (20Hz-20KHz in general). To prevent seeing flash of the LED by human eyes, it is suggested to set the PWM dimming frequency between 100-200Hz.

Analogue dimming control and application sample

Analogue dimming circuit

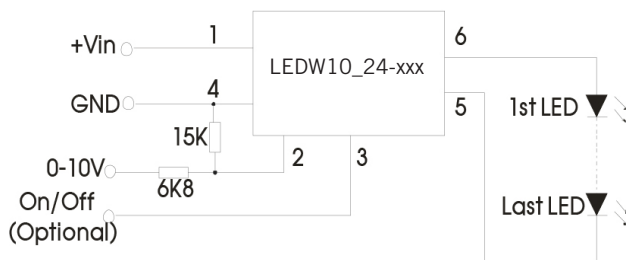

Note:

The voltage drop of all LEDs in the datasheet is 3.3-3.8V during actual application, the number or LEDs can be confirmed based on the actual voltage drop and output voltage of LEDs. This product does not support hot-Plug use.

Analogue input voltage and output current

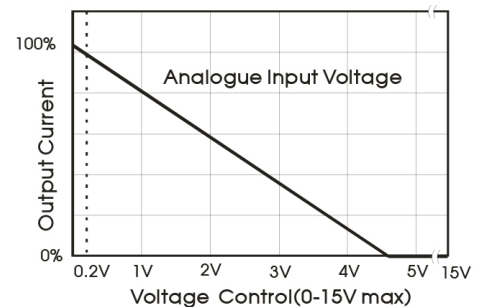

LEDW10_24 Series

Constant current power LED driver - Wide Input - Isolated & Regulated

Typical characteristics

Temperature Derating Curve

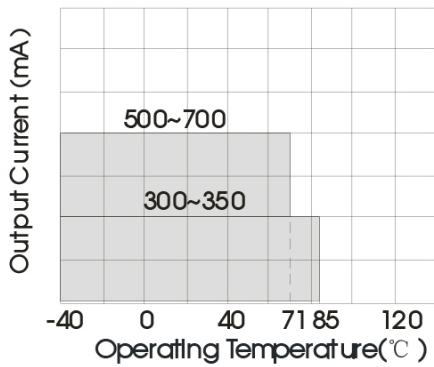

Efficiency

Vin=12V

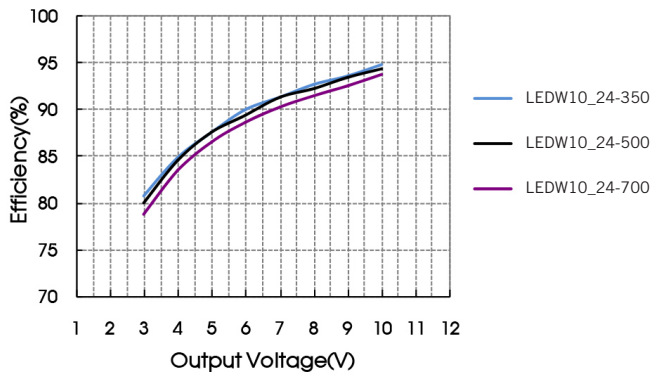

Vin=24V

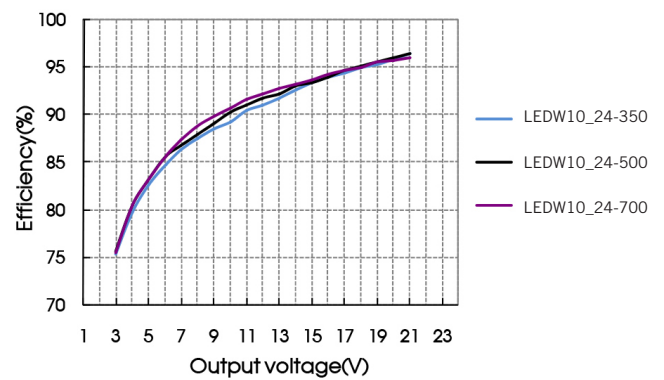

Vin=36V

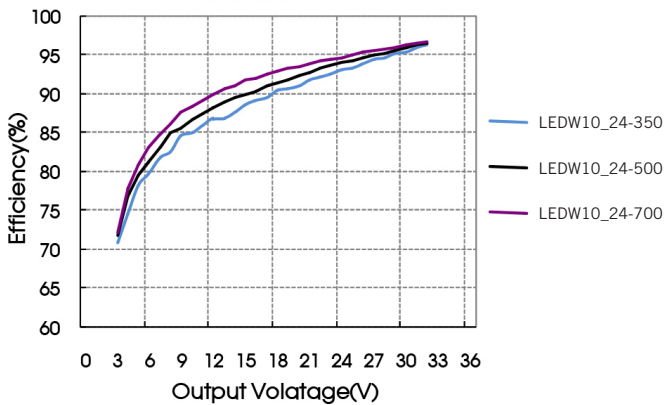

Vin=48V

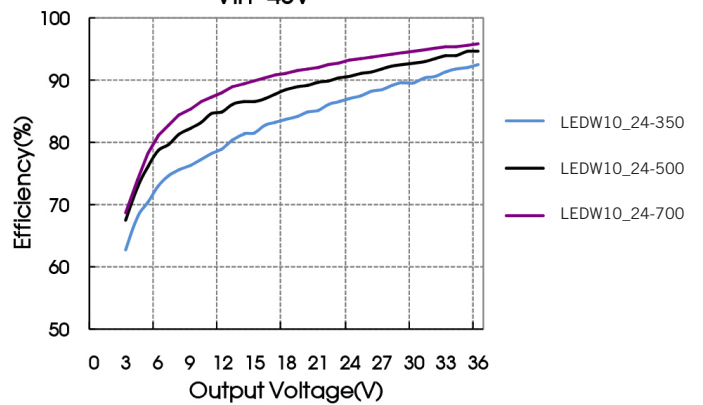

LEDW10_24 Series

Constant current power LED driver - Wide Input - Isolated & Regulated

Mechanical dimensions and footprint

THIRD ANGLE PROJECTION 

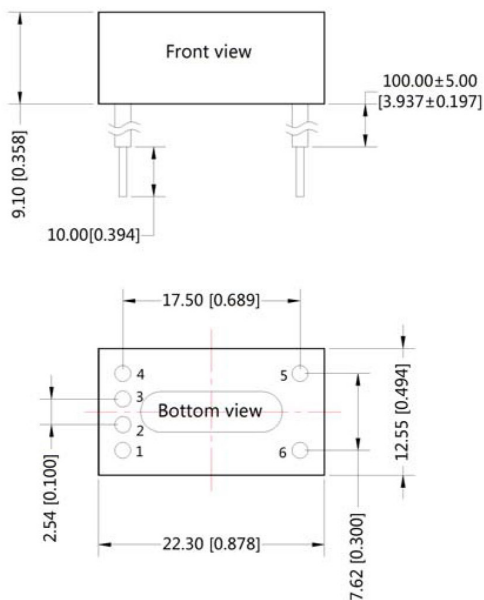

Pin	Function	Comments
1(red)	Vin	DC Supply
2(yellow)	AnalogDimming	Leave open if not use
3(white)	PWM/On/Off	Leave open if not use
4(black)	GND	Do not connect to -Vout
5(white)	-Vout	LED Cathode connection
6(yellow)	+Vout	LED Anode connection

Note:

Unit :mm[inch]

General tolerances: ±0.25[±0.010]

Lead internal diameter: 0.76[0.030]

Lead external diameter: 1.60[0.063]

Lead wire spec: UL1569 300V 105°C