

GP2Y0A21YK
Distance Measuring
Sensor

Issue Date: July 19, 2001
No: ED-01161

REV. 01/01	July 19, 2001
MODEL NO. GP2Y0A21YK	PAGE 2/10

REFERENCE

1. Application

This specification applies to the outline and characteristics for analog output type distance measuring sensor, Model No. GP2Y0A21YK.

2. Outline

Refer to the attached drawing No. SOD07071.

3. Ratings and characteristics

3-1 Constitution diagram : Refer to the attached sheet, page 5.

3-2 Absolute maximum ratings : Refer to the attached sheet, page 5.

3-3 Electro-optical Characteristics : Refer to the attached sheet, page 6.

3-4 Timing chart : Refer to the attached sheet, page 6.

4. Reliability

Refer to the attached sheet, page 7.

5. Outgoing inspection

Refer to the attached sheet, page 8.

6. Supplement

6-1 GP2Y0A21YK Example of Output distance characteristics

Refer to the attached sheet, page 9.

6-2 GP2Y0A21YK Example of output characteristics with inverse number of distance

Refer to the attached sheet, page 10.

6-3 ODS materials

This product shall not contain the following materials.

Also, the following materials shall not be used in the production process for this product.

Materials for ODS : CFC_s, Halon, Carbon tetrachloride,
1.1.1-Trichloroethane (Methylchloroform)

6-4 Brominated flame retardants

Specific brominated flame retardants such as the PBBO_s and PBB_s are not used in this device at all.

6-5 Product mass : Approx. 3.6g

7. Notes

- 7-1 Lens of this device shall be kept cleanly. There are cases that dust, water or oil and so on deteriorate the characteristics of this device. Please consider in actual application.
- 7-2 In case that protection cover is set in front of the emitter and detector portion, the protection cover which has the most efficient transmittance at the emitting wavelength range of LED for the GP2Y0A21YK ($\lambda=870\text{nm}\pm 70\text{nm}$), shall be recommended to use. The face and back of protection cover should be mirror polishing. Also, as there are cases that the characteristics may not be satisfied with according to the distance between the protection cover and the GP2Y0A21YK or the thickness of the protection cover, please use the GP2Y0A21YK after confirming the operation sufficiently in actual application.
- 7-3 In case that there is an object near to light exits of the sensor between the sensor and the detected object, please use this device after confirming sufficiently what the characteristics of this sensor do not change by the object.
- 7-4 When the detector surface receive direct light from the sun, Tungsten lamp and so on, there are cases that it can not measure the distance exactly. Please consider the design that the detector does not receive direct light from such light source.
- 7-5 Distance between sensor and mirror reflector can not sometimes measure exactly. In case of changing the mounting angle of the GP2Y0A21YK, it may measure the distance exactly.
- 7-6 In case that reflective object has boundary line clearly, there is cases that distance can not measure exactly. At that time, if direction of boundary line and the line between emitter center and detector center parallels, it is possible to decrease deviation of measuring distance.

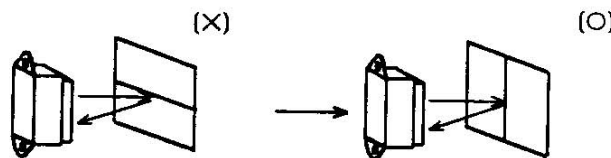

- 7-7 In order to decrease measuring error by moving direction of object, we recommend to mount the sensor like below drawing.

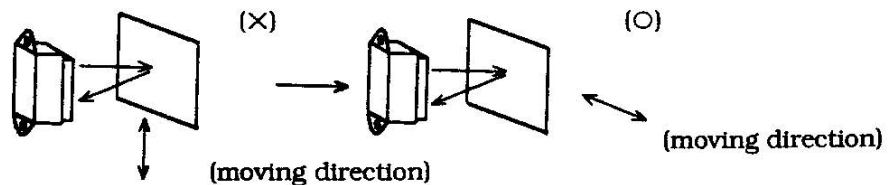

- 7-8 In order to stabilize power supply line, we recommend to connect a by-pass capacitor of $10\ \mu\text{F}$ or more between Vcc and GND near the GP2Y0A21YK.
- 7-9 Please don't do washing. Washing may deteriorate the characteristics of optical system and so on.
- 7-10 There are some possibilities that the sensor inside the case package with lens may be exposed to the excessive mechanical stress. Please be careful not to cause any excessive pressure on the case package with lens and also on the PCB at the assembly and inserting of the set .

REFERENCE

2. Outline

(Stamp)

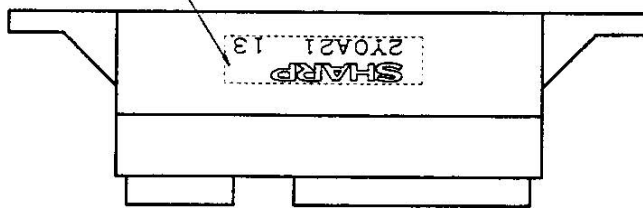

Stamp (Example)

SHARP

2Y0A21 1 3

Model name

Month (1 to 9, X,Y,Z)
Year (2001:1)

Light emitter side

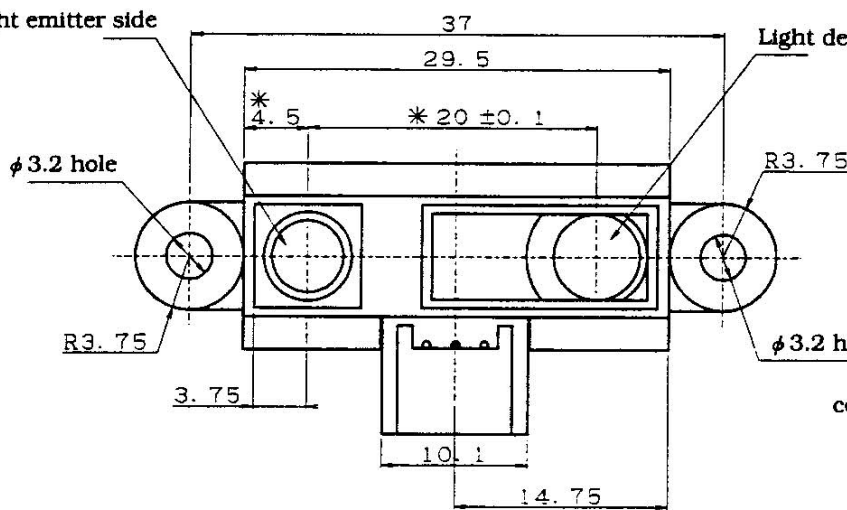

Light detector side

Lens case

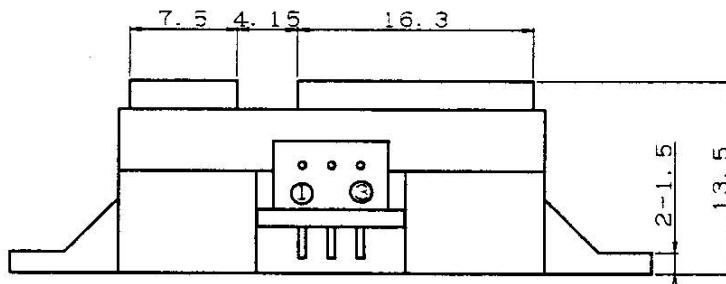
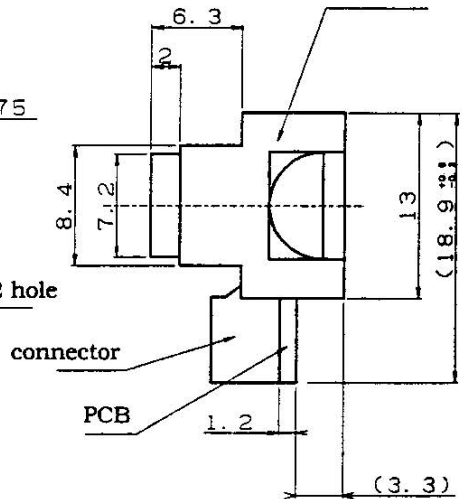

Connector signal

	Signal name
①	V _o
②	GND
③	V _{cc}

Connector : J.S.T. TRADING COMPANY, LTD.
S3B-PH

Material

Lens : Acrylic acid resin
(Visible light cut-off resin)

Case : Carbonic ABS
(Electro-conductive resin)

PCB : Paper phenol

(Scale : 2/1) (Unit : mm)

- Note 1) * dimension shall be reference lens center.
2) Unspecified tolerance shall be ±0.3mm.
3) (): Reference value

Name	GP2Y0A21YK Outline Dimensions
Drawing No.	SOD07071

3. Ratings and characteristics

3-1 Constitution diagram

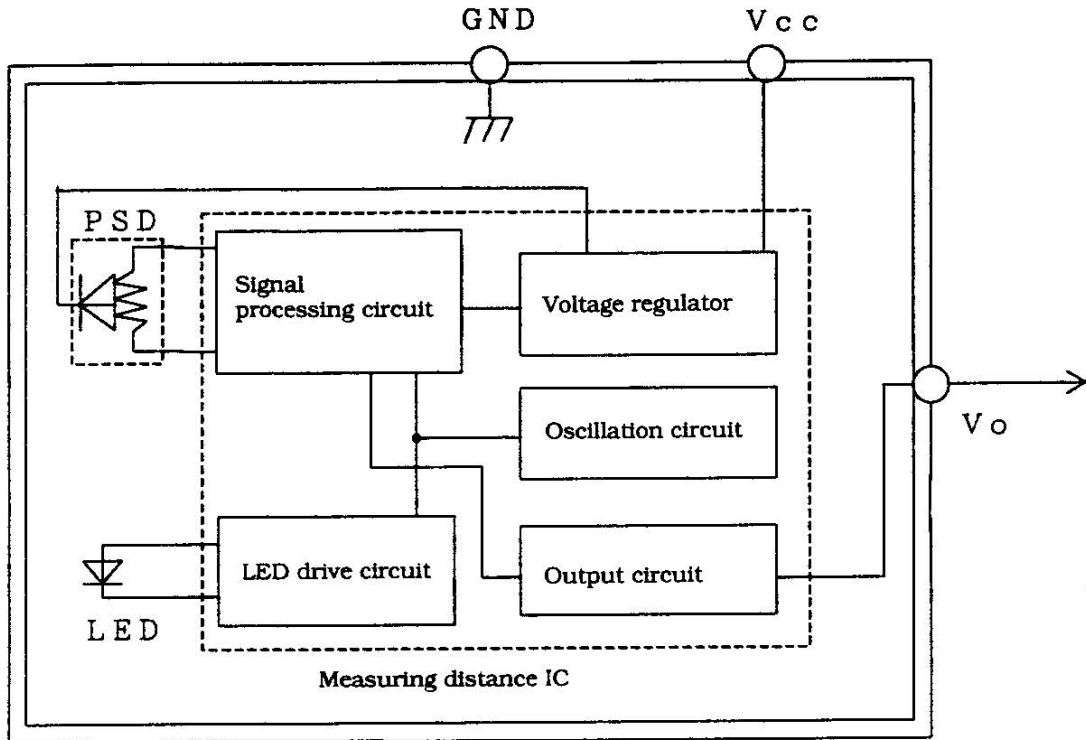

3-2 Absolute maximum ratings

(Ta=25°C, Vcc=5V)

Parameter	Symbol	Rating	Unit	Remark
Supply voltage	Vcc	-0.3 to +7	V	-
Output terminal voltage	Vo	-0.3 to Vcc+0.3	V	-
Operating temperature	Topr	-10 to +60	°C	-
Storage temperature	Tstg	-40 to +70	°C	-

• Operating Supply Voltage

Parameter	Symbol	Rating	Unit	Remark
Operating Supply Voltage	Vcc	4.5 to 5.5	V	-

3-3 Electro-optical Characteristics

(Ta=25°C, Vcc=5V)

Parameter	Symbol	Conditions	Min.	Typ.	Max.	Unit
Measuring distance range	ΔL	(*1)	10	-	80	cm
Output terminal voltage	V_o	L=80cm (*1)	0.25	0.4	0.55	V
Output voltage difference	ΔV_o	Output change at L change (80cm \rightarrow 10cm) (*1)	1.65	1.9	2.15	V
Average supply current	I_{cc}	L=80cm (*1)	-	30	40	mA

※ L : Distance to reflective object

(*1) Using reflective object : White paper (Made by Kodak Co. Ltd. gray cards R-27 · white face, reflective ratio ; 90%)

3-4 Timing chart

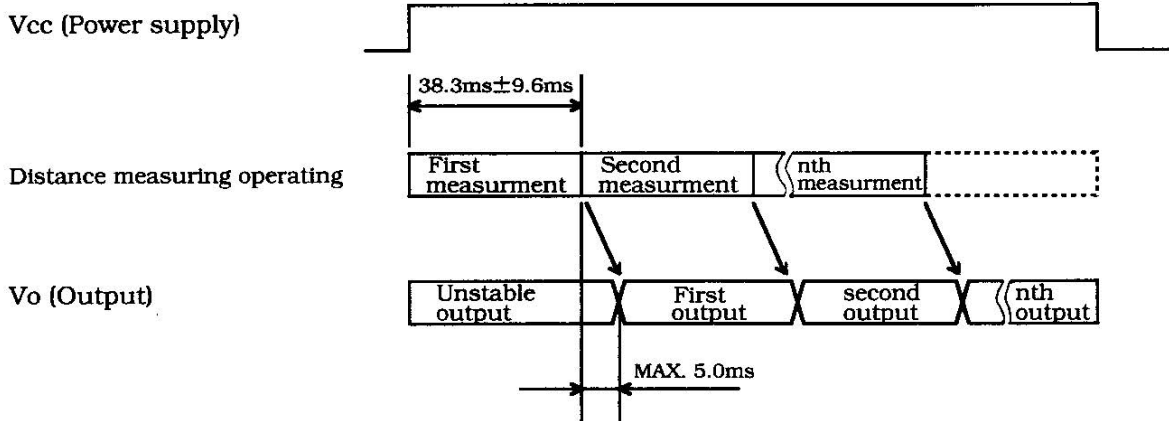

July 19, 2001
 PAGE 7/10
 REFERENCE

4. Reliability

The reliability of products shall satisfy items listed below.

Confidence level : 90%
 LTPD : 20%/40%

No.	Test Items	Test Conditions	Failure Judgement Criteria	Samples (n) Defective(C)
1	Temperature cycling	1 cycle -40°C ↔ +70°C (30min) (30min) 25 cycles test	Initial × 0.8 > Vo Vo > Initial × 1.2 (*1)	n=11, C=0
2	High temp. and high humidity storage	+40°C, 90%RH, 500h		n=11, C=0
3	High temp. storage	+70°C, 500h		n=11, C=0
4	Low temp. storage	-40°C, 500h		n=11, C=0
5	Operation life (High temp.)	+60°C, Vcc=5V, 500h		n=11, C=0
6	Mechanical shock	1000m/s ² , 6.0ms 3times/±X, ±Y, ±Z direction		n= 6 , C=0
7	Variable frequency vibration	10 to 55 to 10Hz/1min Overall amplitude : 1.5mm 2h/X, Y, Z direction		n= 6 , C=0

*1 Test conditions are according to 3-3 Electro-optical characteristics.

*2 After test, measurement shall be measured after leaving under the normal temperature and the normal humidity for two hours. But, no dew point.

5. Outgoing inspection

(1) Inspection lot

Inspection shall be carried out per each delivery lot.

(2) Inspection method

A single sampling plan, normal inspection level II based on ISO 2859 shall be adopted.

Defect	Inspection items and test method	AQL(%)
Major defect	Electro-optical characteristics defect (In para. 3-3)	0.4
Minor defect	Defect on appearance and dimension * Crack, split, chip, scratch, stain	1.0

* Split
Chip
Scratch
Stain

One which affects the characteristics of para. 3-3 shall be defect.

6-1 GP2Y0A21YK Example of Output distance characteristics

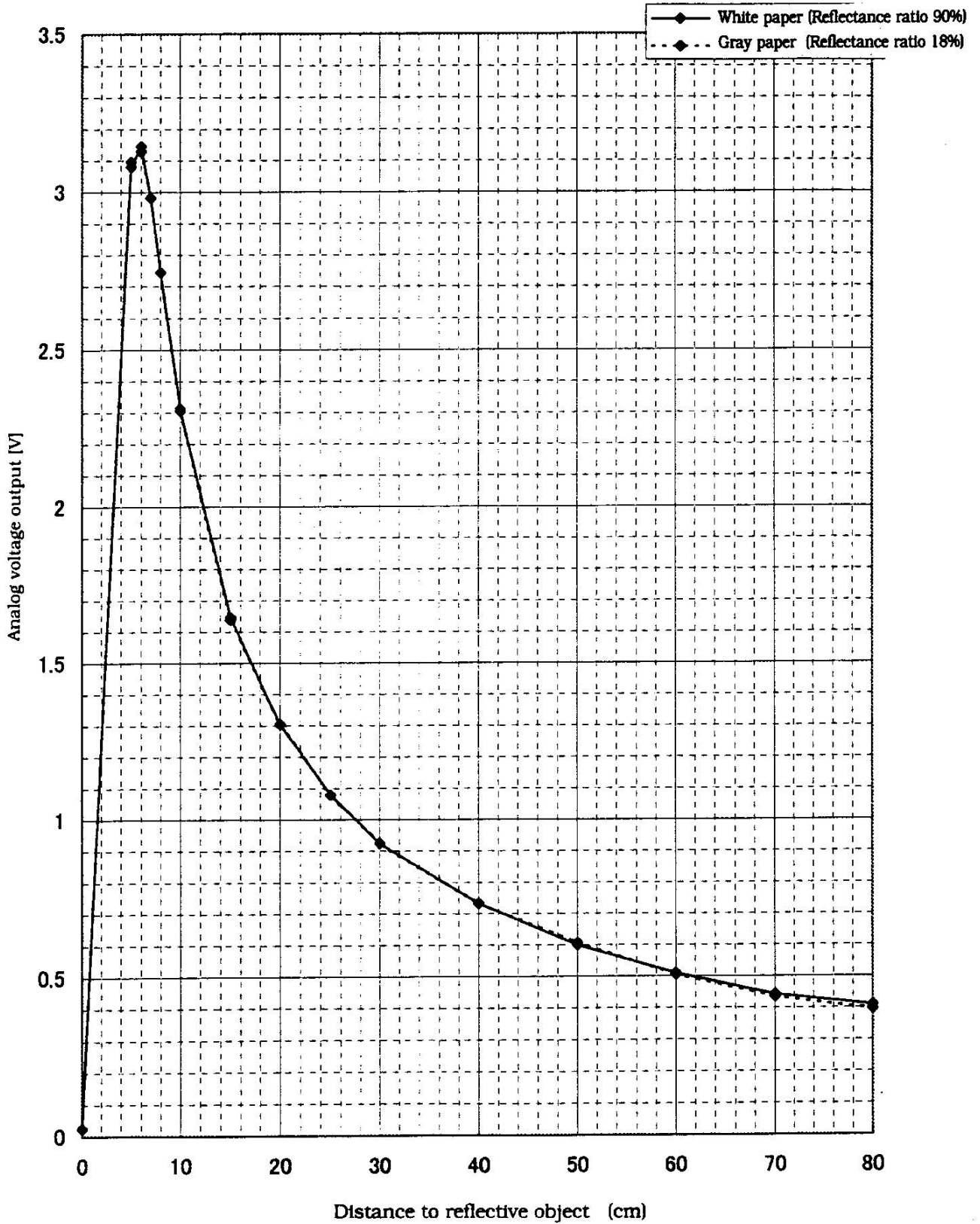

6-2 GP2Y0A21YK Example of output characteristics with inverse number of distance

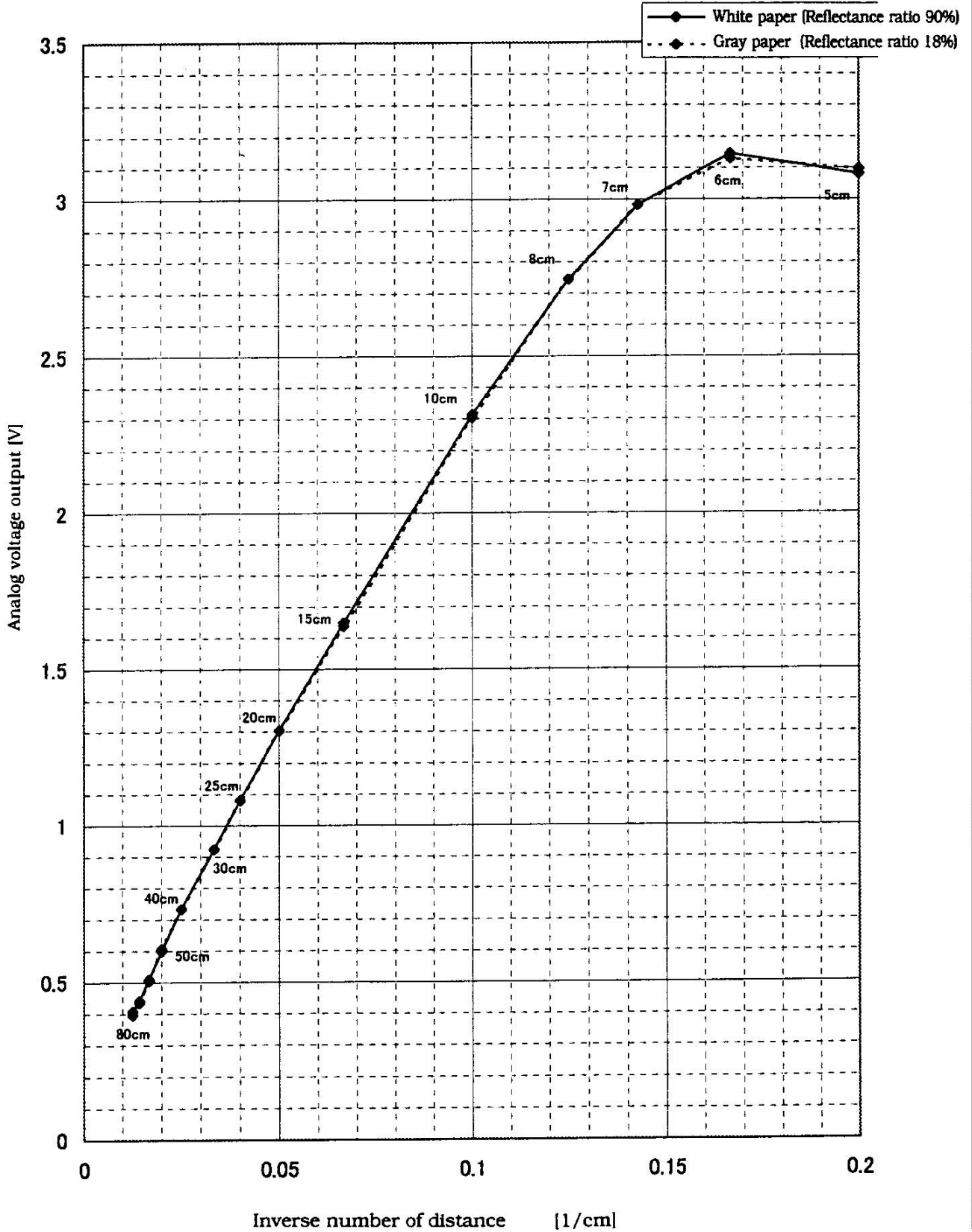

SPECIFICATIONS ARE SUBJECT TO CHANGE WITHOUT NOTICE.

Suggested applications (if any) are for standard use; See Important Restrictions for limitations on special applications. See Limited Warranty for SHARP's product warranty. The Limited Warranty is in lieu, and exclusive of, all other warranties, express or implied. ALL EXPRESS AND IMPLIED WARRANTIES, INCLUDING THE WARRANTIES OF MERCHANTABILITY, FITNESS FOR USE AND FITNESS FOR A PARTICULAR PURPOSE, ARE SPECIFICALLY EXCLUDED. In no event will SHARP be liable, or in any way responsible, for any incidental or consequential economic or property damage.

SHARP®

NORTH AMERICA

SHARP Microelectronics of the Americas
5700 NW Pacific Rim Blvd.
Camas, WA 98607, U.S.A.
Phone: (1) 360-834-2500
Fax: (1) 360-834-8903
Fast Info: (1) 800-833-9437
www.sharpsma.com

EUROPE

SHARP Microelectronics Europe
Division of Sharp Electronics (Europe) GmbH
Sonninstrasse 3
20097 Hamburg, Germany
Phone: (49) 40-2376-2286
Fax: (49) 40-2376-2232
www.sharpsme.com

JAPAN

SHARP Corporation
Electronic Components & Devices
22-22 Nagaike-cho, Abeno-Ku
Osaka 545-8522, Japan
Phone: (81) 6-6621-1221
Fax: (81) 6117-725300/6117-725301
www.sharp-world.com

TAIWAN

SHARP Electronic Components
(Taiwan) Corporation
8F-A, No. 16, Sec. 4, Nanking E. Rd.
Taipei, Taiwan, Republic of China
Phone: (886) 2-2577-7341
Fax: (886) 2-2577-7326/2-2577-7328

SINGAPORE

SHARP Electronics (Singapore) PTE., Ltd.
438A, Alexandra Road, #05-01/02
Alexandra Technopark,
Singapore 119967
Phone: (65) 271-3566
Fax: (65) 271-3855

KOREA

SHARP Electronic Components
(Korea) Corporation
RM 501 Geosung B/D, 541
Dohwa-dong, Mapo-ku
Seoul 121-701, Korea
Phone: (82) 2-711-5813 ~ 8
Fax: (82) 2-711-5819

CHINA

SHARP Microelectronics of China
(Shanghai) Co., Ltd.
28 Xin Jin Qiao Road King Tower 16F
Pudong Shanghai, 201206 P.R. China
Phone: (86) 21-5854-7710/21-5834-6056
Fax: (86) 21-5854-4340/21-5834-6057

Head Office:

No. 360, Bashen Road,
Xin Development Bldg. 22
Waigaoqiao Free Trade Zone Shanghai
200131 P.R. China
Email: smc@china.global.sharp.co.jp

HONG KONG

SHARP-ROXY (Hong Kong) Ltd.
3rd Business Division,
17/F, Admiralty Centre, Tower 1
18 Harcourt Road, Hong Kong
Phone: (852) 28229311
Fax: (852) 28660779
www.sharp.com.hk

Shenzhen Representative Office:

Room 13B1, Tower C,
Electronics Science & Technology Building
Shen Nan Zhong Road
Shenzhen, P.R. China
Phone: (86) 755-3273731
Fax: (86) 755-3273735