

# EC220

Phone Jack

date/contact: 190619/OWE  
 finishing: CCO  
 last update: -  
 drawing: 90037  
 unit: mm  
 tolerance: -  
 page: 1/1

EVE GmbH  
 Hollefeldstr. 16  
 48282 Emsdetten  
 Tel.: +49 (0) 25 72 / 93 51 - 0  
 Fax: +49 (0) 25 72 / 93 51 - 24  
 www.eve.de • info@eve.de

Approval:  granted!  
 Freigabe erteilt!

Date  
 Datum

Signature/Stamp  
 Unterschrift / Stempel

RoHS  
 COMPLIANT

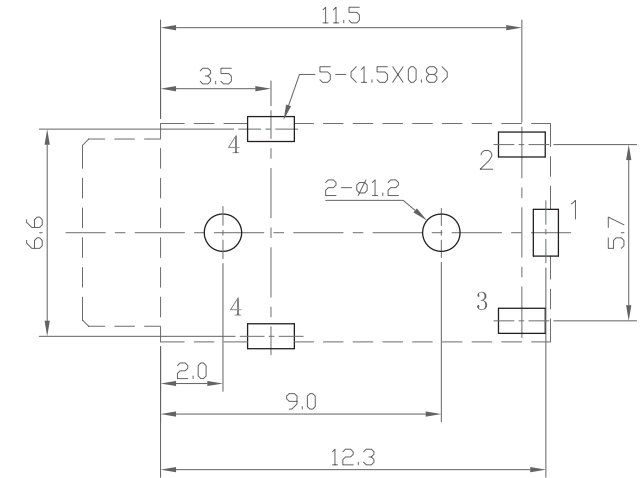
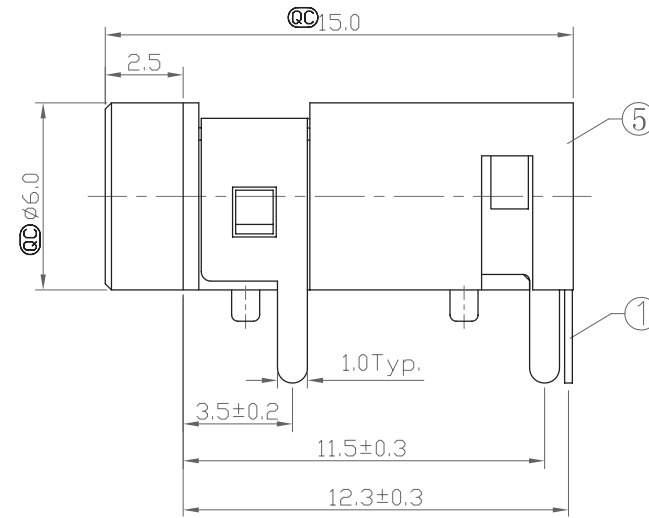
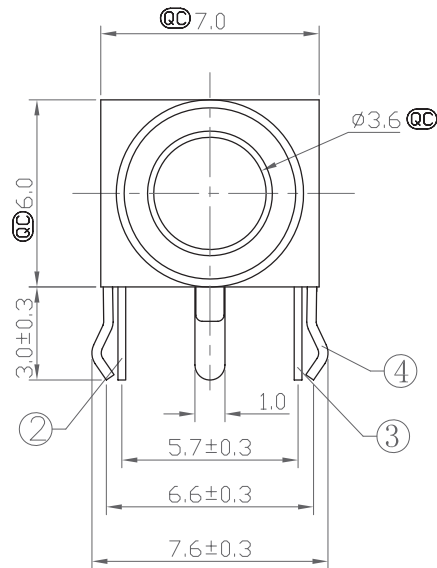

### SCHEMATIC

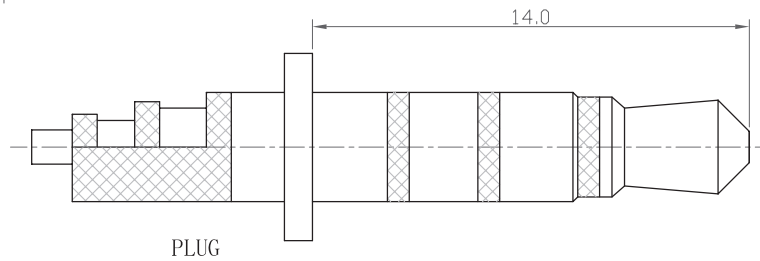
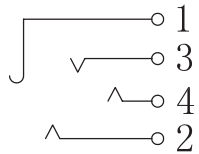

P. C. B. LAYOUT  
 TOP VIEW

5	HOUSING	1	PBT	
4	4# CONTACT FOOT	1	PHOSPHOR BRONZE	Sn-Plating
3	3# CONTACT FOOT	1	BRASS	Sn-Plating
2	2# CONTACT FOOT	1	PHOSPHOR BRONZE	Sn-Plating
1	1# CONTACT FOOT	1	PHOSPHOR BRONZE	Sn-Plating
NO.	DESCRIPTION	QTY	MATERIAL	REMARK

UNLESS OTHERWISE  
 SPECIFIED DIMENSIONS  
 ARE IN MM TOLERANCE  
 DECIMALS ANGULAR  
 .XX ±0.25 ±5°  
 .XXX ±0.1 ±5°  
 DO NOT SCALE DRAWING

