

Bild 2: Schaltbild der Spannungsversorgung des RGBC555

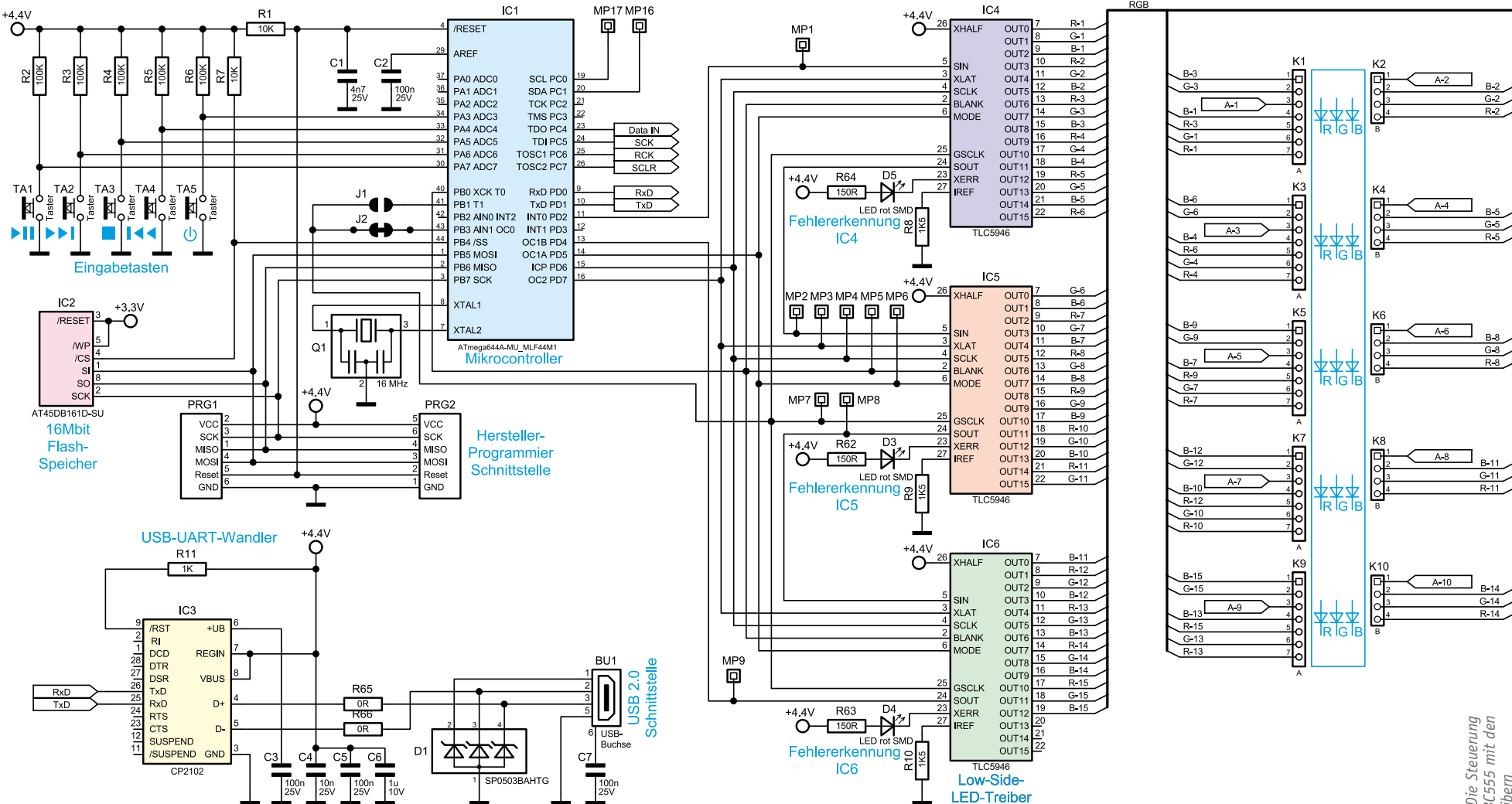

Bild 3: Die Steuerung des RGB555 mit den LED-Treibern

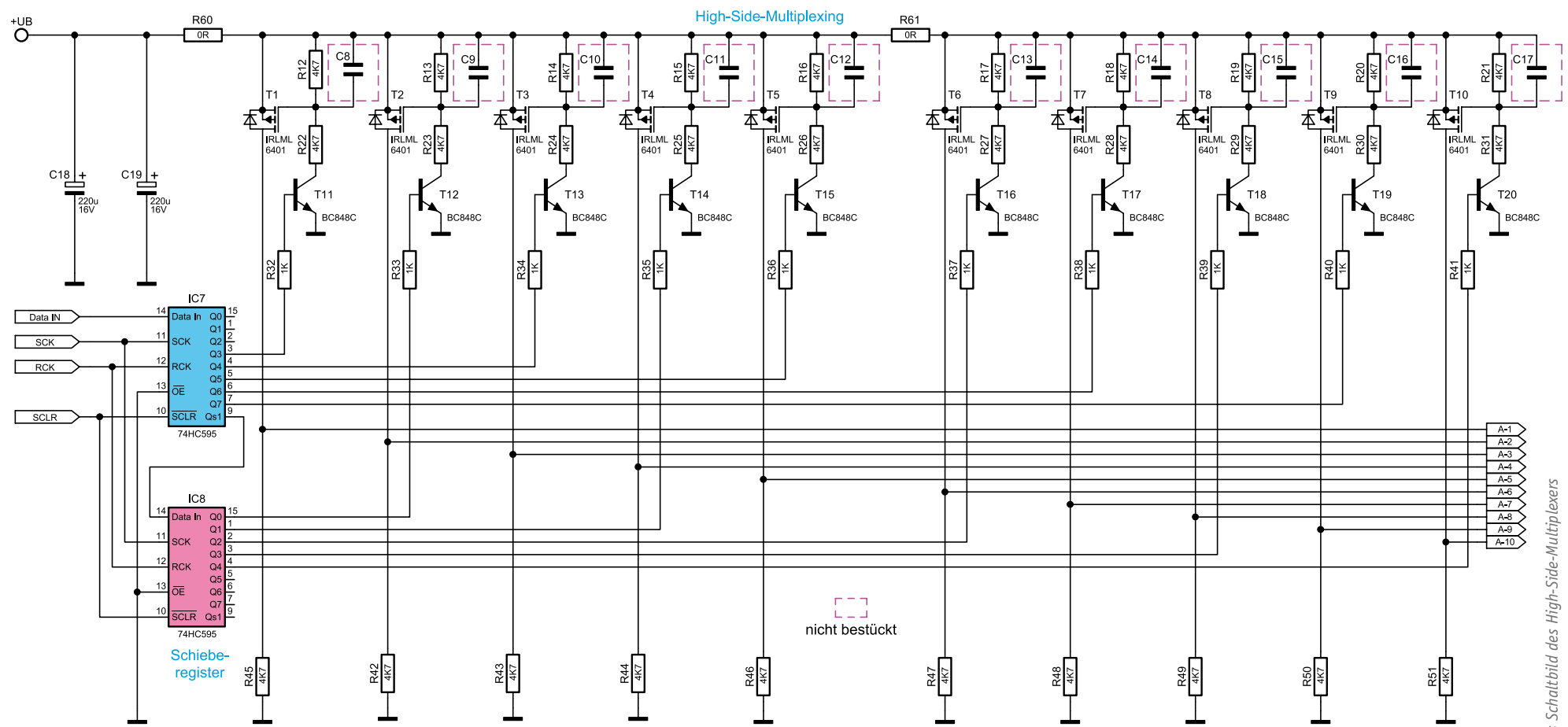

Bild 4: Das Schaltbild des High-Side-Multiplexers