

UG1094UWP

BNC female Chassis
P. C. Board mounting

date/contact: 070306/KEM
last update: -
drawing: 93769
scale: -
unit: mm
tolerance: -
page: 1/1

EVE GmbH
Hollefeldstr. 16
48282 Emsdetten
Tel.: +49 (0) 25 72 / 93 51 - 0
Fax: +49 (0) 25 72 / 93 51 - 24
www.eve.de • info@eve.de

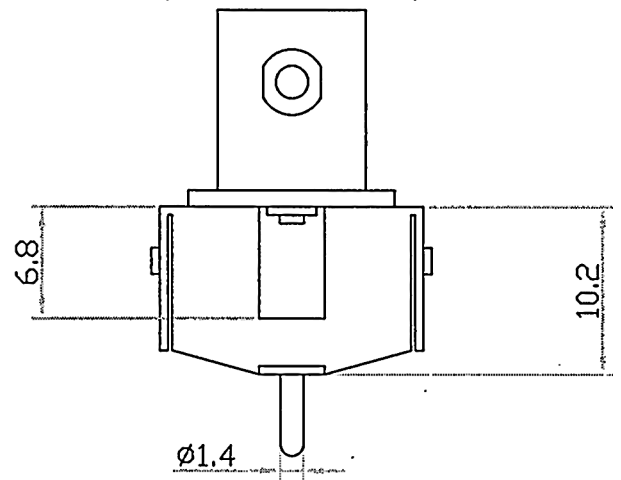
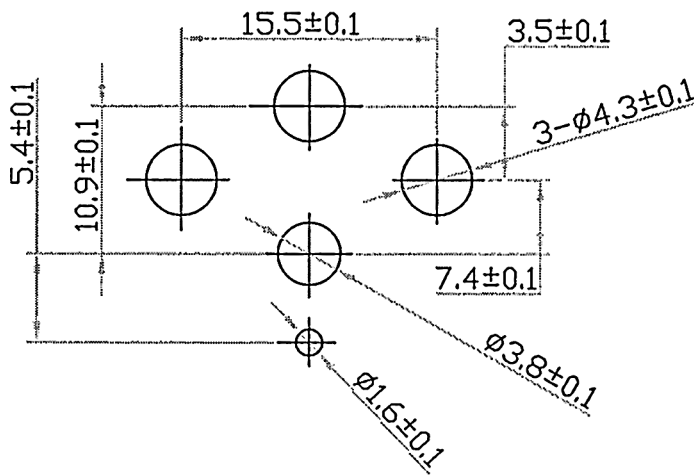
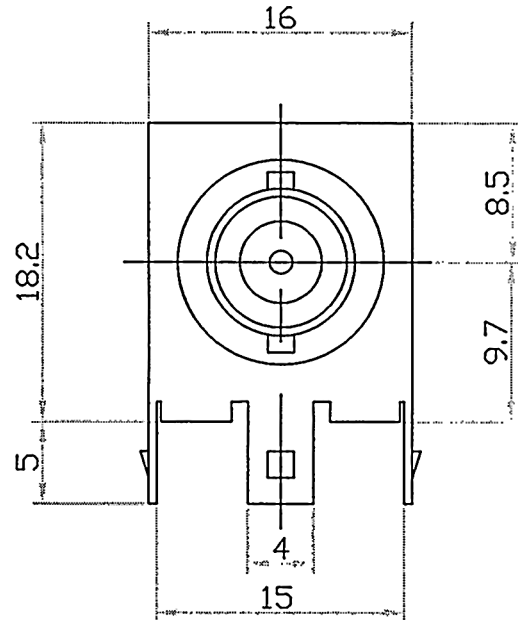
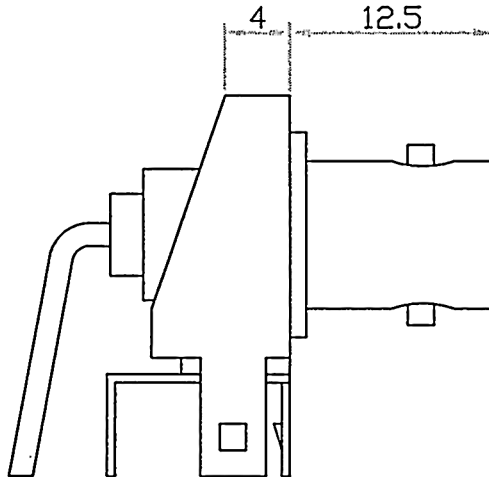

NO	DESCRIPTION	MATERIAL	FINISH	QTY	DIMENSIONS ARE IN MILLIMETERS UNLESS OTHERWISE SPECIFIED TOLERANCES			
6	UNT	IRON	NICKEL	1	0.5-5	±0.2		
5	WASHER	IRON	NICKEL	1	5-30	±0.4		
4	PIN	BRASS	GOLD	1	30-120	±0.6		
3	INSULATOR	DELTRIN	WHITE	1	120-315	±1		
2	BODY	ZINC	NICKEL	1	315-1000	±1.6		
1	SHELL	IRON	NICKEL	1	1000-2000	±2.4		
					SCALE		ISSUE	